

57700

Sliding Door Operator for New Installations

A High-Security Locking and Operating System for Correctional Facilities

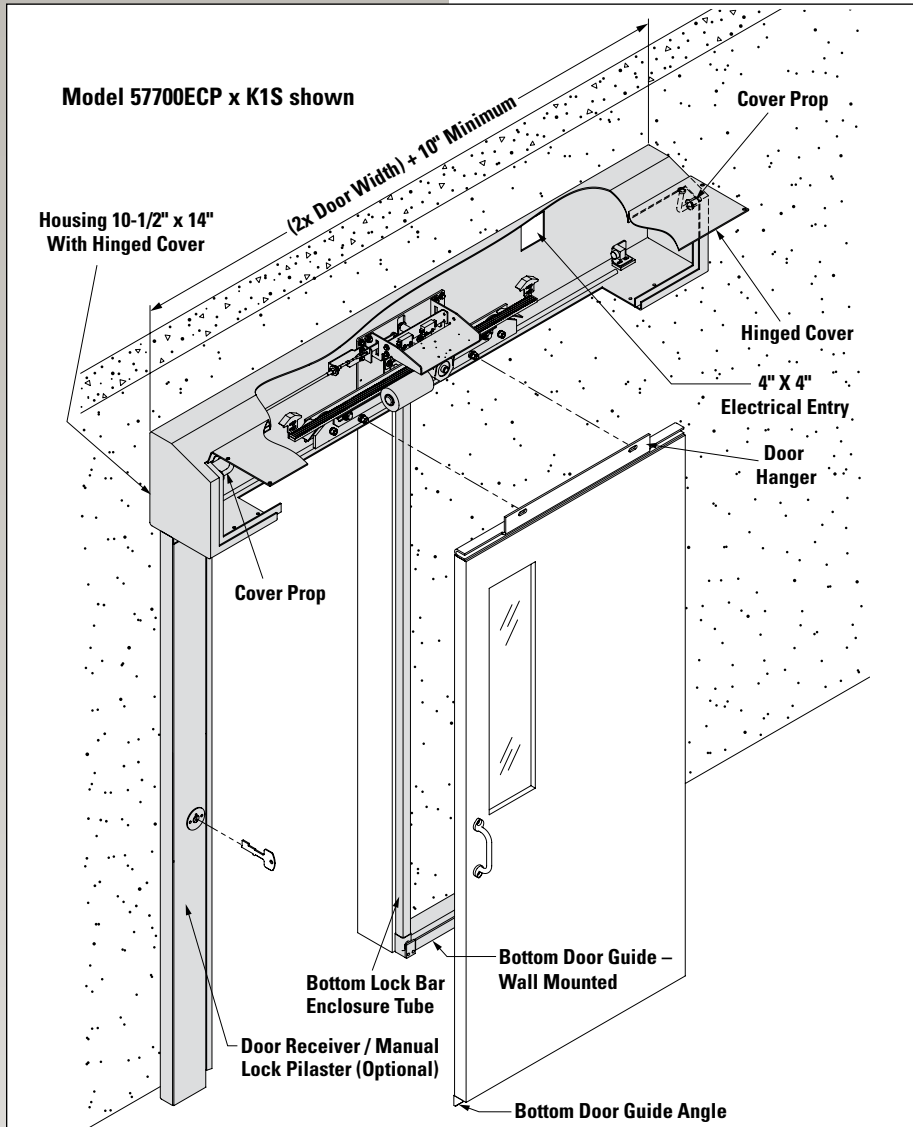

Built for Durability

All functional components of the 57700 are designed/selected to provide a long life cycle consistent with the frequent use and infrequent maintenance typical in many correctional facilities. Fabricated steel parts are zinc electroplated for corrosion resistance. The door rollers are of hardened steel and turn on permanently lubricated ball bearings.

An R.R. Brink Locking Systems proprietary motor controller and printed circuit relay board serve to control door travel direction and speed. The drive train is clutchless and door travel speed is adjustable electronically by a mechanism plate dial. When a door is blocked intentionally during travel, the pressing force is factory set at approximately 40 lbs and there is no potential for motor/drive train damage. It is possible to reverse door travel direction continuously and instantly without mechanism damage.

The motor, plug-in relays and switches are standard products of domestic manufacturers and are recognized by independent testing laboratories. They are factory wired to quick-disconnect plugs or terminal strips allowing ease of replacement. The standard 57700 unit operates on 115VAC line voltage. The gearmotor is a direct current, permanent magnet type with right angle reducer utilizing permanently lubricated bearings and gearbox. The gearhead power output is 1/8 HP, which is sufficient to unlock and move the weight of standard sized detention type doors. The door is attached to the drive train at all times and is never in a "free wheeling" condition.

Remote Operation

Typically, individual door remote electrical operation of the 57700 is activated from a control room switch console. A key switch can be provided for electric control at the door. Cell door rows can be controlled simultaneously or in a pre-selected group. Limit switches located on the mechanism plate serve to signal door condition (i.e. closed and deadlocked or open/unlocked) by pilot lights at the control panel).

Manual Override

A manual means is always provided to enable unlocking without electric power. With a corridor or passage door, it is customary to provide a cable linkage from a hip-high paracentric key lock located in a front door receiver pilaster. With a cell row, individual door unlocking via key or tool from the horizontal mechanism housing and /or remote manual all door (gang) unlocking from an end-of-row cabinet are typical. When manually unlocked, either at the door or remotely, the door can be moved easily by hand pushing. Importantly, the door is not disconnected from the drive train and, therefore, is never in a frictionless or freewheeling condition where slam force can inflict bodily injury to a person in the doorway.

Applications

The 57700 is used with new construction and for complete replacement of existing sliding corridor and cell door locking and operating devices. The locking and operating mechanism is contained in fabricated sheet steel housings that wall mount. (For retrofit applications, refer to the 57700R catalog page.)

Unitary Design

Electrical and mechanical parts associated with the locking and movement of a door are contained on a single plate that is non-handed and, thus, easily replaced irrespective of door travel direction. (This feature allows the user to stock one spare mechanism plate as a precaution against a breakdown.) Two point, concealed deadlocking is effected at the edge of the door – top and bottom – in both the open and closed positions. An adjustable rubber bumper fixes the open door position.



R.R. BRINK LOCKING SYSTEMS, INC.

500 Earl Road • Shorewood, IL 60404

Tel: 815-744-7000 • Fax: 815-744-7020

www.rrink.com

57700

Component Specification Standard (and optional) Door Locking and Operating Mechanism Components

- Motor drive/lock mechanism plate and door hanger/rack assembly. U.S. Patent No. 6,585,303.
- Mechanism Plate – zinc electroplated steel plate (9" x 15" x 1/4") contains all functional components for locking, operating and indicating status of a door. The assembly is non-handed and is easily accessible and removable.
- Gearmotor – standard 115VAC & 5 amp.
- Rack and pinion drive standard.
- Electric door controls – Door movement speed is adjustable via a mechanism plate knob (rheostat). Trimpots are provided to improve motor speed regulation and to set motor torque (i.e. a door's pressing force). An electro-mechanical clutch and/or mechanical torque limiter are not employed.
- Track – hardened steel round (9/16" diameter) welded in place.
- Door hanger – 1/4" formed steel construction with 3/16" vertical adjustment via eccentric bushings (2) and 1" horizontal slotted adjustment to compensate for field misalignments.
- Door rollers – two solid steel wheels (cell door 2-3/4" O.D., corridor door 3-3/4" O.D.) fitted with double shielded, permanently lubricated ball bearings. Attachment to door carriage via a high tensile strength steel bolt/lock washer/hex nut. Tandem roller assemblies provided for \geq 450lb door.
- Bottom door guide angle and wall guide – 1/4" thick steel construction.
- Top lock bolt – 7/8" diameter stainless steel
- Bottom lock – cast iron body encloses 13/16" diameter stainless steel locking ball.
- Door status indication switch – 15 amp @ 125/250VAC

Standard Mechanism Housing Material and Construction

- Horizontal housing – formed from 3/16" thick steel sheet. Openings are baffled to block the insertion of foreign objects.
- Mechanism access cover – formed from 1/8" thick steel sheet, hinged for easy access and provided with hold-open cover props. Attachment to the horizontal housing is via pinned Torx® security screws. (Optionally, a common lock bar operated from a remote mechanical release cabinet can secure cell row housing covers.)
- Vertical lock bar enclosure – 10 ga. x 1-1/2" square steel tube

- Vertical door receiver/manual lock pilaster (optionally furnished with a manual paracentric key and/or electric key switch hip-high unlock control) – formed from 10 ga. sheet steel with 10 ga. steel cover plates attached with pinned Torx® security screws. Hard rubber bumpers (2) are incorporated in the receiver surface to cushion the impact of a closing door.
- Housing sheet metal – primed for paint. standard. Zinc electroplate (electro-galvanize) finish available when specified (e.g. exterior installations).

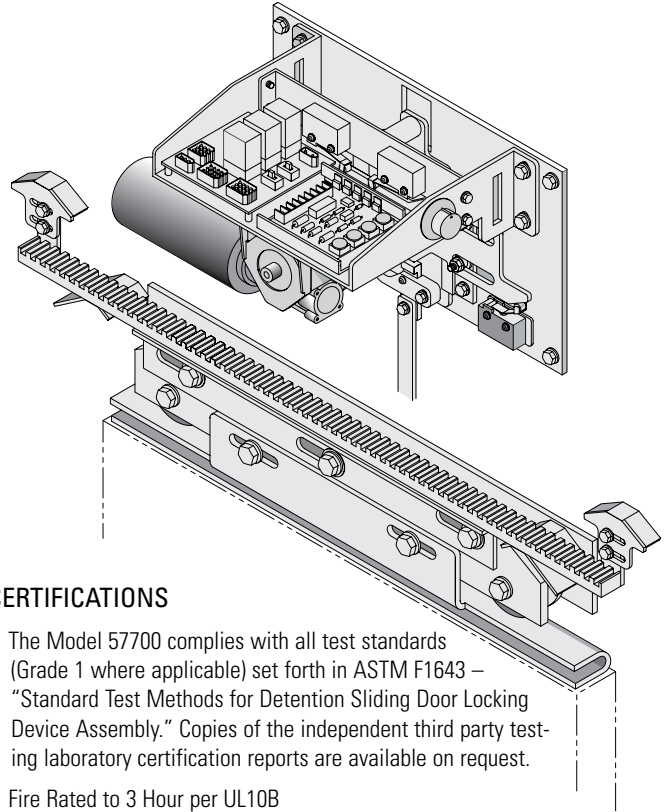

CERTIFICATIONS

- The Model 57700 complies with all test standards (Grade 1 where applicable) set forth in ASTM F1643 – “Standard Test Methods for Detention Sliding Door Locking Device Assembly.” Copies of the independent third party testing laboratory certification reports are available on request.
- Fire Rated to 3 Hour per UL10B

Ordering Information:

1. Consult R.R. Brink Locking Systems, Inc. (RRBLS) technical service personnel when planning a 57700 installation. Provide door construction, size and approximate weight including glazing (door width and weight limit \leq 6'-0" and 1000lbs, respectively - not suitable for vehicle gates). A door 450lb to 1000lb requires special reinforcement. Unless otherwise agreed, it is the responsibility of the RRBLS customer (e.g. contractor, end user) to provide accurate field dimensions. Upon acceptance of an order, RRBLS will prepare and issue a setting plan drawing for customer approval prior to initial fabrication.

NOTICE: Unless specifically included by an RRBLS bill of material and/or quotation, miscellaneous metalwork (e.g. masonry mounting plate embeds, closure plates, and shims) is by others.

2. The standard RRBLS product warranty is the earliest of one (1) year from the project turnover date or eighteen months from shipment date inclusive of defects in factory supplied labor and material only and excludes operational failure due to faulty installation labor by others and/or abusive use (see the RRBLS *Product Warranty Policy* catalog page).

3. When ordering or specifying the 57700, indicate feature options as follows:
 - a) No. 57700CD/F or U typically specified for cell doors with bent plate door receiver (i.e. no vertical manual lock/door receiver pilaster) and mechanical door unlocking from the overhead horizontal mechanism housing. For latter means, select either unlocking access from the front of the housing via tool from a lockable port (suffix "F") or via paracentric key from the underside of the housing (suffix "U"). (Add a lockable mechanical release cabinet(s) for a cell row(s) requiring all door remote mechanical unlocking. Add wire raceway(s) and, if required, harness(s) for a cell row(s) not designed with individual conduit feeds.)
 - b) No. 57700ECP x K1S (or K2S) – usually specified for corridor/entrance doors with hip high manual paracentric key lock release in front door receiver pilaster – keyed one (K1S) or two (K2S) sides of doorway.
 - c) No. 57700ECP x K1S (or K2S) x 1KSC (or 2KSC) – same as b) with the addition of a commercial cylinder key switch(s) on one or two sides of doorway.
 - d) No. 57700ECP x K1S (or K2S) x 1KSM (or 2KSM) – same as b) with the addition of a RRBLS mogul cylinder key switch(s) on one or two sides of doorway.
 - e) No. 57700ECP x K1S (or K2S) x 1KSP (or 2KSP) – same as b) with the addition of a RRBLS paracentric cylinder key switch(s) on one or two sides of doorway.



R.R. BRINK LOCKING SYSTEMS, INC.

500 Earl Road • Shorewood, IL 60404
Tel: 815-744-7000 • Fax: 815-744-7020
www.rrbrink.com