

## What We Do

*Founded in 1976, R.R. Brink Locking Systems, Inc. specializes in the design and manufacture of high security electromechanical and mechanical locks. We offer a full line of products designed for correctional institutions where remote control of cell and corridor doors is often mandatory. Our reputation has been established on product innovation, quality workmanship and installed product back-up service.*

*While our principal market is detention facilities, RRBLS door locking products are ideal where abuse and attack resistance are of paramount concern. Banks, casinos, museums, offices, and homeland security installations use RRBLS products where door access control systems require durable and strong locks.*

*RRBLS encourages architects and specifiers to consult our factory personnel for assistance with the application and technical aspects of our products. We design special mountings to adapt our locks for retrofitting to an existing swinging door/frame. We advise on the suitability of our sliding door electric operating and/or locking mechanisms to replace obsolete and worn installations.*

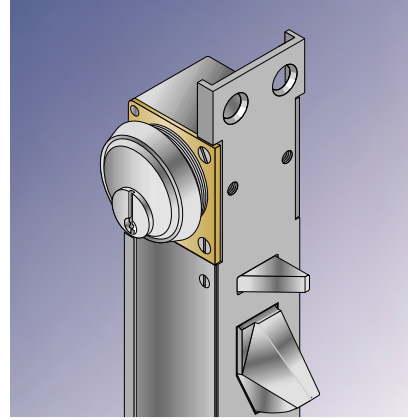

# 1020

## Extra Heavy Duty Construction – Latch and Deadbolt with Mogul Key Cylinder and Lever Eskort or Knob Trim

5/8" Latch Throw – 1" Deadbolt Throw – Stainless Steel Construction

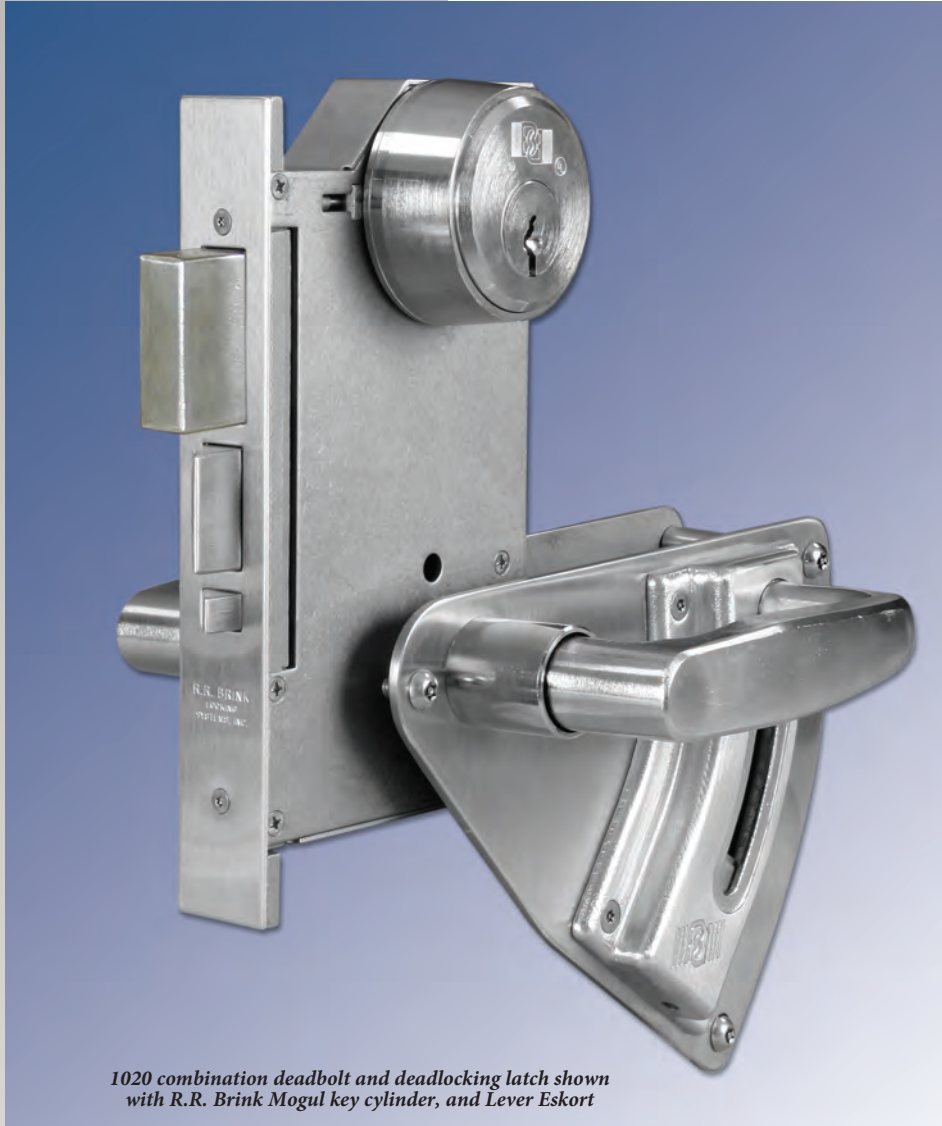

1020 combination deadbolt and deadlocking latch shown with R.R. Brink Mogul key cylinder, and Lever Eskort



Security Knob-Trim Available Safety Knob (optional)

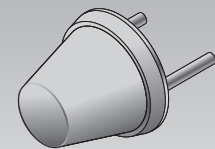

The conical shape of the optional safety knob prevents holding a door closed by grasping the knob.



Stainless steel strike plate



R.R. BRINK LOCKING SYSTEMS, INC.  
500 Earl Road--Shorewood, IL 60404  
Tel: 815-744-7000--Fax: 815-744-7020  
www.rrbrink.com

### Application

The 1020 series of Mogul key and Lever Eskort or knob operated deadlocking latch/deadbolt is ideal for use in detention institutions as well as commercial, government, and industrial buildings for utmost physical security. The large-scale design accommodates an oversized latch and deadbolt plus the RRBLs proprietary Mogul key cylinder. These institutional grade construction features and tamper resistant fittings provide exceptional structural strength

to impede forced and surreptitious entry. The 1020 meets ASTM F1450 and F1577 impact test requirements as certified by an independent testing laboratory.

Appropriate for locking hollow metal doors in secure perimeters and/or high usage openings in all building types. A function is available to suit most passage requirements. (See lock function selection chart.)

# 1020

## Construction Specification

- 5/8" throw latch
- 1" throw deadbolt
- Cast stainless steel armor front – 1/2" thick
- Cast latch, auxiliary latch, and deadbolt of stainless steel
- Lock case, strike plate, springs, and other working parts of stainless steel
- Exposed fasteners – pinned "Torx" head.
- Optional RRBLs proprietary Mogul key cylinder

## Trim (Specify)

- Lever Eskort (specify LE) – Solid cast brass and wrought stainless steel. Enables the designer/specifier to satisfy Americans with Disabilities Act (ADA) accessibility requirements and avoid intentional, forced lever breakage.
- Security Knob & Rose (specify KR) –solid brass – free spinning inactive knob
- Safety Knob (specify SK) – Solid brass, conical shaped knob serves to limit handgrip to prevent holding a door closed. Specifically designed for jail/prison sleeping room doors.

## Standard Finishes

- Face Plate – Wrought Satin Stainless Steel (ANSI 630, US32D)
- Lever Eskort Trim – Satin Chrome on Brass (ANSI 626, US26D) and Wrought Stainless Steel (ANSI 630, US32D)

### 1020 Illustrated

Note: This illustration is for information only. Do not use for construction. Door and frame preparation drawings and wiring schematics are available from the factory.

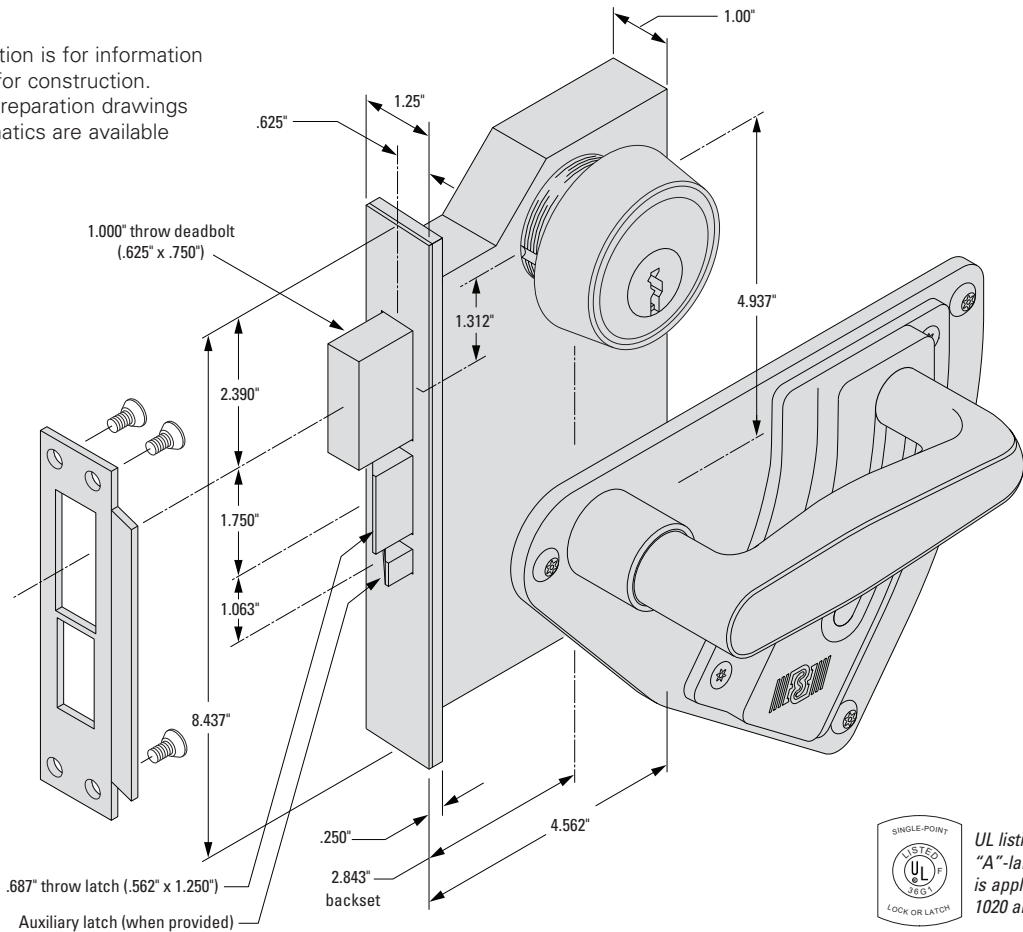

UL listing is for a 3-hour "A"-label fire door and is applicable to models 1020 and 1030.

## Custom Applications

Consult with our technical service personnel regarding custom applications such as retrofits to existing lock installations, special mounting conditions, and Lever Eskort compatibility with other manufacturers' locksets.

## Ordering Information

Model	Description	Key cylinders
1022	Keyed one side only	Mogul type (priced separately)
1026	Keyed both sides	Mogul type (priced separately)

Example: **1022** – **201** – **SK** – **LHR** – **US26D**

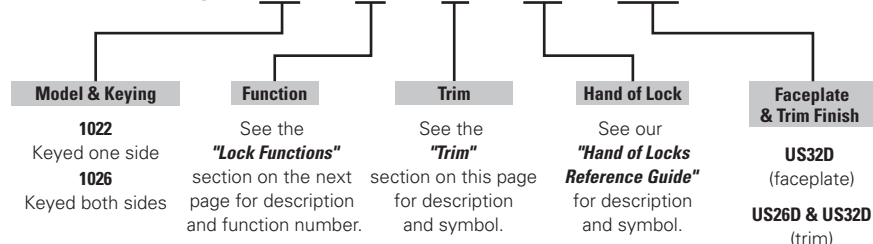

## How to Specify Lock Functions

Refer to the diagrams to determine the lock function designation number for a particular application. To specify the function of a 1020 Series mechanical lock, you must first determine the following:

1. The “inside” and “outside” of the opening.
2. Lock keyed one (1022) or both (1026) sides.
3. The desired lever/knob functions for the “inside” and “outside” and choose the corresponding lock function number (i.e. 1022-201, etc.).
4. The hand of the lock (refer to “Hand of Locks Reference Guide” for explanation of lock handing).

### Lock-Function Notations

- (A) Active Trim – retracts the latchbolt only
- (B) Active Trim – retracts the deadbolt and latch simultaneously
- (I) Inactive Trim – functions as a door pull only (optional) free spinning knob
- 1 Outside cylinder operates deadbolt only
- 2 Inside cylinder operates deadbolt only
- 2T Inside thumbturn operates deadbolt only
- 3 Outside cylinder operates deadbolt and deadlatch
- 4 Inside cylinder operates deadbolt and deadlatch
- 4T Inside thumbturn operates deadbolt and deadlatch
- 5 Outside cylinder operates deadlatch

## 1020 Lock Functions Lever Trim shown – Knob Trim available

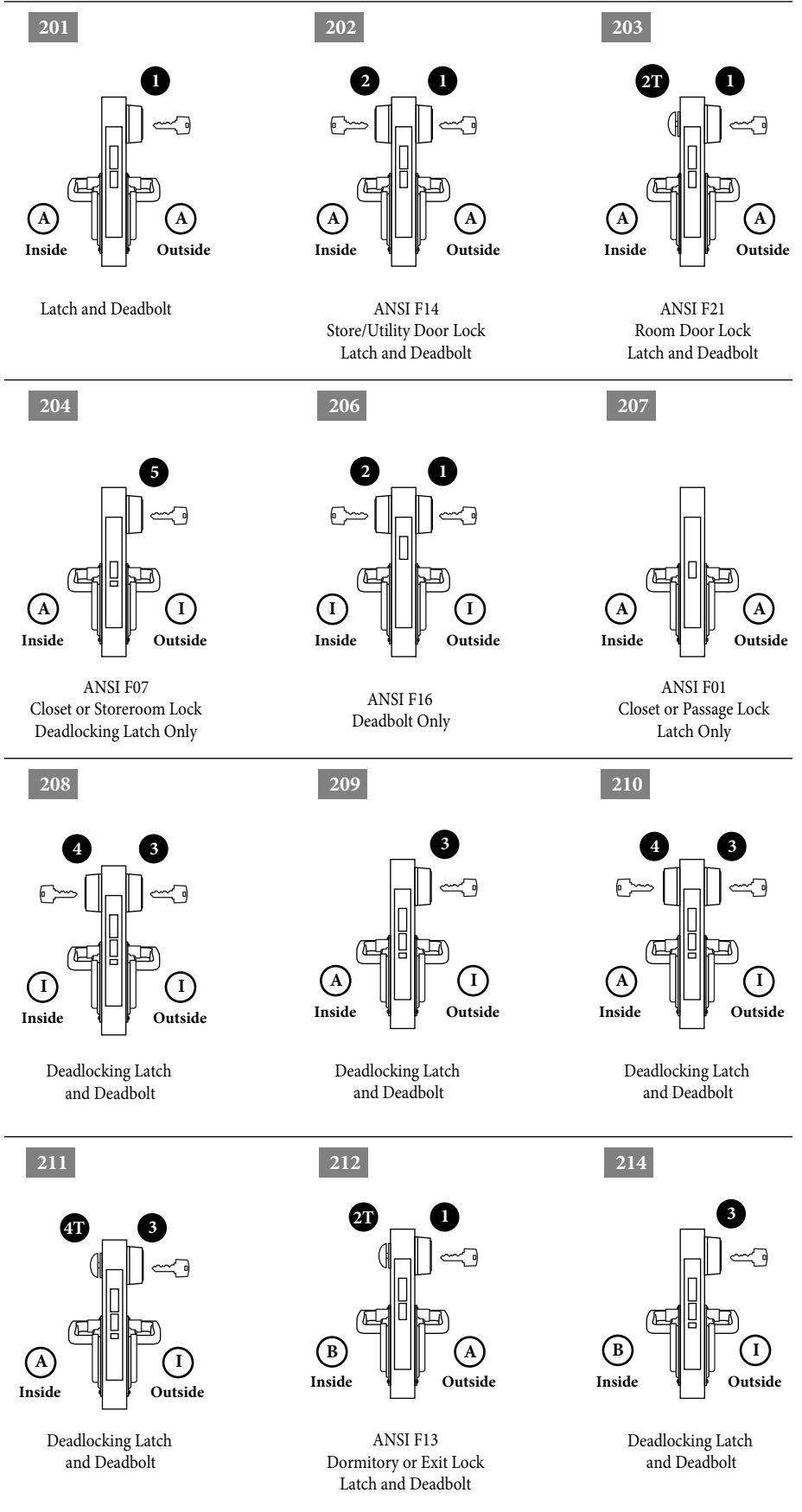

R.R. BRINK LOCKING SYSTEMS, INC.

500 Earl Road--Shorewood, IL 60404  
Tel: 815-744-7000--Fax: 815-744-7020  
www.rrbrink.com

# 1040/1060

## High Security Automatic Deadlocking Latch Extra Heavy Stainless Steel Construction

3/4" Latch Throw – Hollow Metal Door Mortise Mount – Free-Spinning Inactive Knob



1040/1060 shown with R.R. Brink Mogul key cylinder, standard knobs and escutcheon



Lever Eskort (optional)

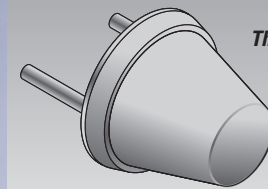

The conical shape of the optional safety knob prevents the holding of a door by grasping the knob.

Safety Knob (optional)



1060 with commercial mortise key cylinder.



**R.R. BRINK LOCKING SYSTEMS, INC.**  
500 Earl Road • Shorewood, IL 60404  
Tel: 815-744-7000 • Fax: 815-744-7020  
www.rrbrink.com

### Application

The 1040/1060 series of key/knob operated deadlocking latches is ideal for use in detention institutions as well as in commercial, governmental and industrial buildings where physical security is of high priority. The design incorporates material strength and tamper resistant fittings to impede forced and/or surreptitious entry. With the optional Lever Eskort trim, the designer/specifier can meet Americans with Disabilities Act (ADA) accessibility standards and insure against intentional, abusive lever breakage.

### Model 1040

The 1040 latchbolt is operated by key or knob/lever from one or two sides — see function chart on page 3. This model does not incorporate a key controlled knob lockout feature.

### Model 1060

The 1060 series provides the same key and knob control as the 1040 model. In addition, there is a mechanism for key control of one or both knobs (or Lever Eskort) to switch from active to inactive (i.e. locked) status and vice versa — see function chart on page 3. An inactive knob or lever is free spinning to prevent forcing. Turning the key toward the hinge stile: First click renders the controlled knob(s) inactive. Turning the key further, until the second click, renders the knob active. Conversely, rotating the key toward the lock stile retracts the latch.

# 1040/1060

## High Security Automatic Deadlocking Latch – Extra-Heavy Stainless Steel Construction

3/4" Latch Throw – Hollow Metal Door Mortise Mount – Free-Spinning Inactive Knob Prevents Lock Damage From Forcing

### Standard Features

- Lock case, armor front, springs, and working parts are made of stainless steel.
- Solid forged-brass trim cannot be removed when the door is in the closed and locked position — all mounting screws are concealed. A locked or inactive knob spins freely to prevent forced breakage of the lock works.
- Latch made of stainless steel with a full 3/4" throw.
- Stainless steel strike plate.
- Fitted for mechanical operation via either RRBLS proprietary "Mogul" or user's commercial key cylinder. (Factory supplied commercial key cylinder optional.)
- Exposed fasteners – pinned "Torx" head.

### Optional Features

- **FKC** – Factory supplied high security commercial key cylinder with collar – two change keys/cylinder.
- **MOG** – Supplied with RRBLS Mogul proprietary 2" diameter 6-pin cylinder – keys are ordered separately (UL listed locking cylinder UL-437).
- **LSS** – Lock status switch trips when the latch is in a deadlocked condition. Used in a signal circuit to indicate lock status – unlocked or deadlocked – via control panel lights and/or alarm devices.

*Note: For positive, tamper resistant signaling of a closed and deadlocked door, a sensitive door position (DPS) switch must be wired in combination with the LSS. Our DPS Nos. 201030 or 201090 are recommended.*

*Note: the LSS switch option requires an electric transit hinge or another wire transfer connection device between the door and the frame.*

### Optional Trim

- **Safety Knob** (specify SK) – Solid brass, conical shaped knob serves to limit handgrip to prevent holding a door closed. Specifically designed for jail/prison sleeping room doors.
- **Lever Eskort** (specify LE) – A lever handle and track set designed to add significant structural integrity to mortise lockset assemblies. When specified with the 1040/ 1060 series, a locked lever is free to rotate due to R.R. Brink's patented free-spinning lever lockout design. A locked lever is not rigid, thereby preventing attempts to vandalize the internal lockworks.

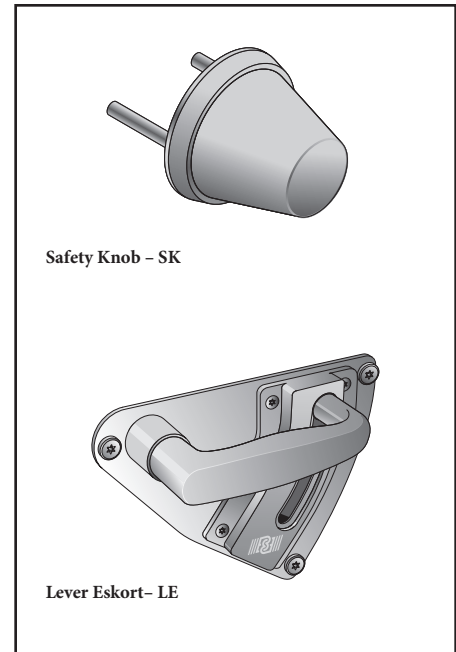

### Trim and Faceplate Finishes

- Faceplate – Satin Stainless Steel (ANSI 630, US32D)  
Trim - Satin Chrome on Brass (ANSI 626, US26D)

### Custom Applications

Consult with our technical service personnel regarding custom applications such as retrofits to existing lock installations, special mounting conditions, and Lever Eskort compatibility with other manufacturers' locksets.

### Ordering Information

1040/1060 – Extra-Heavy Construction Mechanical Lock Series

Model	Description
1042	1040 keyed one side only
1046	1040 keyed both sides
1062	1060 keyed one side only
1066	1060 keyed both sides

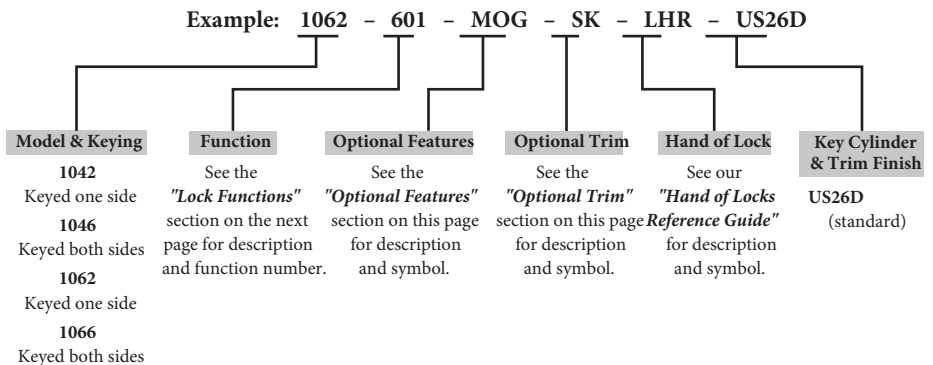

## Lock Functions – How to Specify

Refer to the diagrams below to determine the lock function designation number for a particular application. To specify the function of a 1040/1060 Series mechanical lock, you must first determine the following:

1. The "inside" and "outside" of the opening.
2. Whether the lock will be keyed on one or both sides (1042, 1066, etc.).
3. The desired knob functions for the "inside" and "outside" and choose the corresponding lock function number (i.e. 1062-611, etc.).

4. The hand of the lock (refer to "Hand of Locks Reference Guide" for explanation of lock handing).

Please Note: Knob control key shown only for 1060 locks. Latch retraction key cylinder can be specified on one or both sides for all 1040 functions. (Never specify a key cylinder on active knob side).

## Lock Functions Identified Below

- A:** Active Knob – always operates the latch
- I:** Inactive Knob – functions as a door pull only – free spinning
- C1:** Knob is controlled by Key 1 cylinder
- C2:** Knob is controlled by Key 2 cylinder
- C12:** Knob is key controlled by cylinders on both sides

### 1040 Lock Functions

**401**

Inside  
Outside

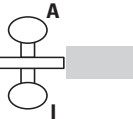

**402**

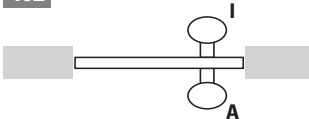

**403**

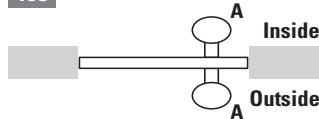

**404**

Inside  
Outside

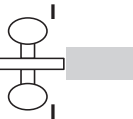

**405**

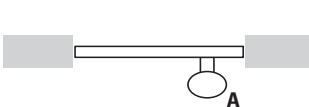

**406**

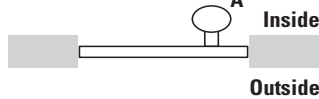

### 1060 Lock Functions

**601**

Inside  
Outside

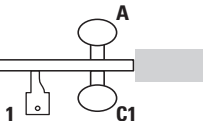

**602**

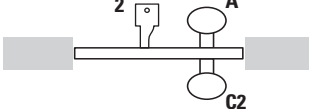

**603**

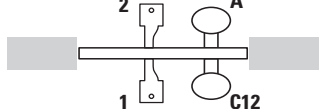

**604**

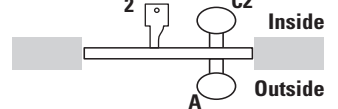

**605**

Inside  
Outside

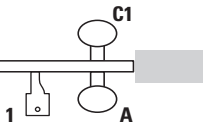

**606**

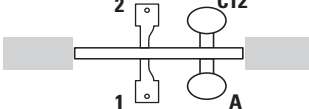

**607**

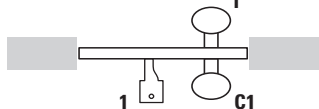

**608**

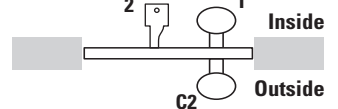

**609**

Inside  
Outside

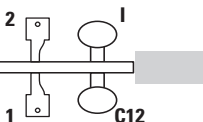

**610**

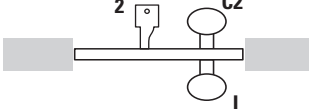

**611**

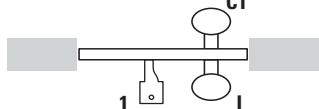

**612**

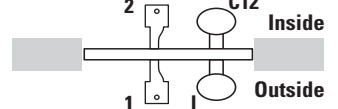

**613**

Inside  
Outside

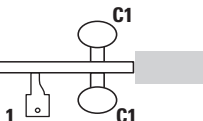

**614**

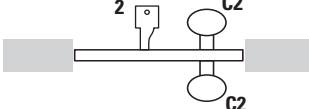

**615**

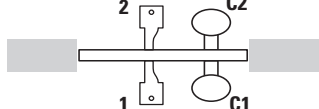

**616**

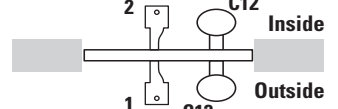

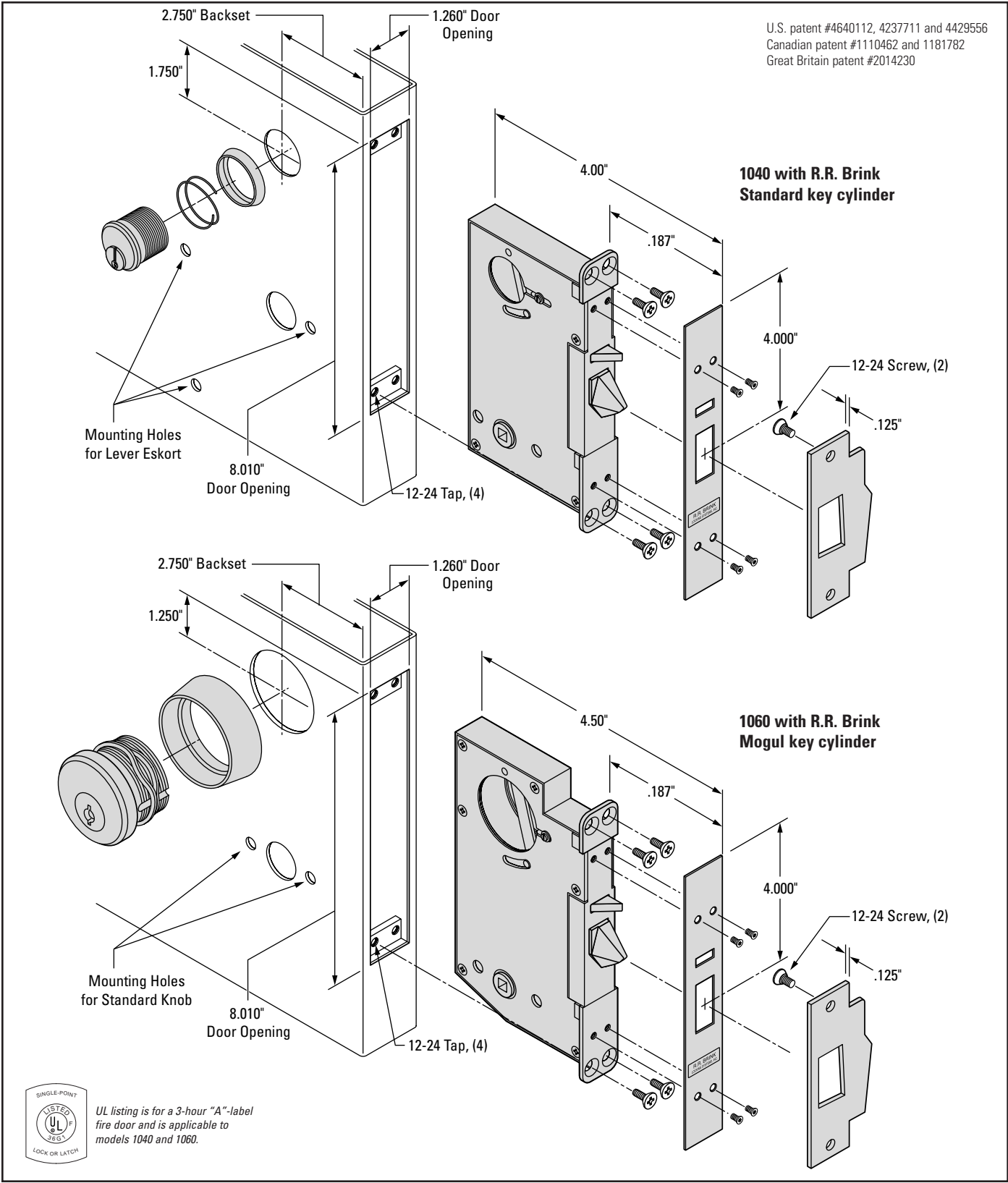

Note: The above illustrations are for information only. Do not use for construction. Door and frame preparation drawings are available from the factory.

**R.R. BRINK LOCKING SYSTEMS, INC.**  
 500 Earl Road • Shorewood, IL 60404  
 Tel: 815-744-7000 • Fax: 815-744-7020  
 www.rrbrink.com



# 1050

## Minimum/Medium Security Automatic Deadlocking Latch with Electric Knob/Lever Control – Heavy Stainless Steel Construction – Hollow Metal Door Mortise Mounting

24VDC electric solenoid knob/lever control actuator – free spinning inactive knob – latch retraction by key and active knob/lever



*1050 shown with Lever Eskort, and RRBS Mogul cylinder*



*Standard Knobs and high security mortise key cylinder*

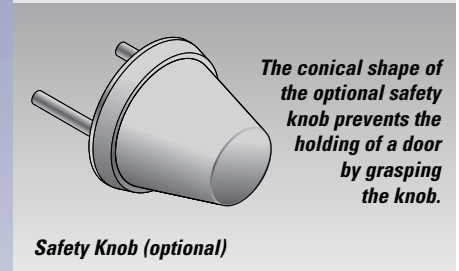

*The conical shape of the optional safety knob prevents the holding of a door by grasping the knob.*

*Safety Knob (optional)*



*1050 with RRBS mogul cylinder*



**R.R. BRINK LOCKING SYSTEMS, INC.**  
500 Earl Road • Shorewood, IL 60404  
Tel: 815-744-7000 • Fax: 815-744-7020  
www.rrbrink.com

### Application

The Model 1050 is a deadlocking latch that affords electric (solenoid actuated) remote control of the knob/lever trim set. It is appropriate for supervised minimum/medium security areas in detention facilities such as passage and office doors. RRBS does not recommend the 1050 for inmate cell doors.

One knob/lever can be electrically locked and unlocked with the opposite either always active or inactive. Also, both knobs/levers can be electrically locked and unlocked simultaneously. *(See Lock Function section on the reverse of this page.)* An internal limit switch is standard to signal at the remote control panel the dead-locked or unlocked status of the latch.

An inactive knob spins freely to prevent forcing. The optional Lever Eskort can be substituted for the standard knobs.

The 1050 is available in one mode—Fail Secure (FSE). With the FSE mode, the controlled knob or lever is locked without power and unlocked with power and, thus, would revert to the locked condition in the event of a power failure. The latch can always be retracted by key.

Since the 1050 is door mounted, a through wire electric transfer hinge or other flexible power connection is required between the door frame and the door.

# 1050

## Standard Features

- Lock case, armor front, springs, and working parts are made of stainless steel.
- Solid brass knob trim cannot be removed when the door is in the closed and locked position – all mounting screws are concealed. A locked or inactive knob spins freely to prevent forced breakage of the lock works.
- Stainless steel rotary movement latch with a full 3/4" throw.
- Stainless steel strike plate – synthetic coated for reduced friction.
- Working parts made of copper alloy or stainless steel.
- Solenoid – constant duty tubular type – 24VDC, 0.33 amp.
- Lock Status Switch (LSS) – Integral limit switch to monitor latch status, (i.e. deadlocked or unlocked) by lights, alarms, and/or other door condition indicators. Commonly connected in combination

with a door position switch to give positive indication that a door is in both the closed and locked position.

- **Indication Module** (specify IM) – For fail secure mode only, plug-in relay module that serves to signal when an electrically controlled knob/lever is unlocked (e.g. via a red control panel pilot light that also indicates an unlocked latch via the standard lock status switch [LSS]). This feature provides an additional sensor to the LSS for monitoring the 1050FSE's locked/unlocked status.
- Fitted for mechanical operation via either RRBLS proprietary "Mogul" or commercial key cylinder. (Factory supplied key cylinder optional.)
- Exposed fasteners – pinned "Torx" head.
- Exposed Faceplate Finish  
Satin Stainless Steel – (ANSI 630, US32D)
- Trim Finish  
Satin Chrome on Brass (ANSI 626, US26D)

## Optional Features

- **Factory Key Cylinder** (specify FKC and all keying information) – High security mortise type with finish matching lock face plate.
- **Mogul Cylinder** (specify MOG and all keying information) – RRBLS six pin mogul cylinder.
- **Lever Eskort** (specify LE) – Enables the designer/specifier to satisfy Americans with Disabilities Act (ADA) accessibility requirements and impede intentional, forced lever breakage.
- **Rectifier** (specify RC) – Attached to 24VDC solenoid lead wires to permit use of 24VAC from transformer.
- **Safety Knob** (specify SK) – Solid brass, conical shaped knob serves to limit handgrip to prevent holding a door closed. Specifically designed for jail/prison sleeping room doors.

## Lock Functions

- A** Active Knob/Lever – always operates the latchbolt
- I** Inactive Knob/Lever – functions as a door pull only – free spinning
- E** Electrically Controlled Knob

Latch retraction by key can be one or both sides.

To specify the lock function, determine the following :

- (1) The "inside" and "outside" of the opening.
- (2) The desired knob functions for the "inside" and "outside" and choose the corresponding lock function number (e.g. 1050-503).
- (3) The hand of the lock (refer to "Hand of Locks Reference Guide" for explanation of lock handing).

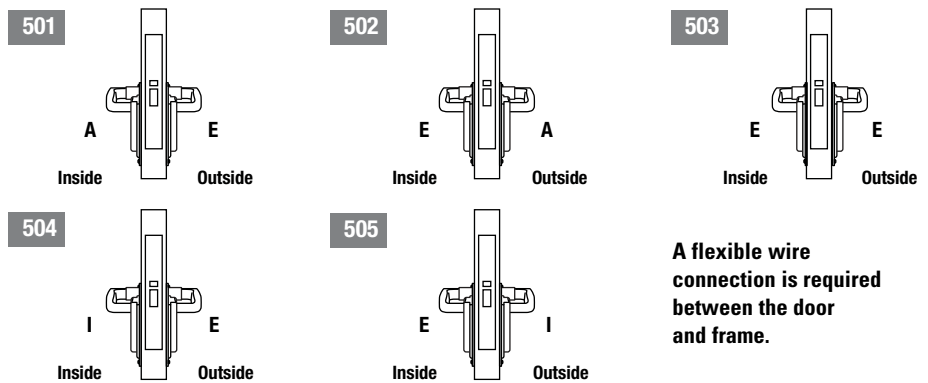

**A flexible wire connection is required between the door and frame.**

## Ordering Information

Model	Description
1052 FSE	1050 keyed one side – Fail Secure
1056 FSE	1050 keyed both sides – Fail Secure

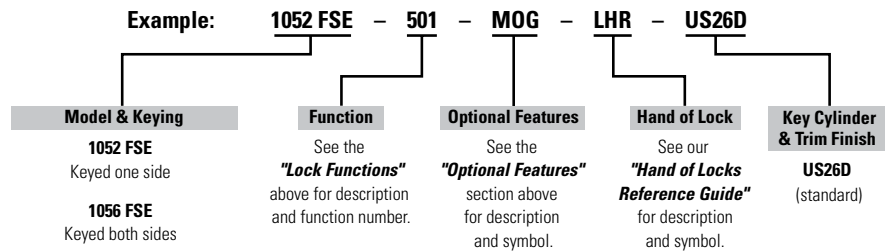

## Keying Information

**One key cylinder only required when specifying 501 or 502 lock functions. Fail secure mode locks with functions 503, 504 and 505 should be keyed on one or two sides so as to meet life safety requirements in the event of power failure.**

## Installation – 1050

Note: This illustration is for information only. Do not use for construction. Door and frame preparation drawings and wiring schematics are available from the factory.

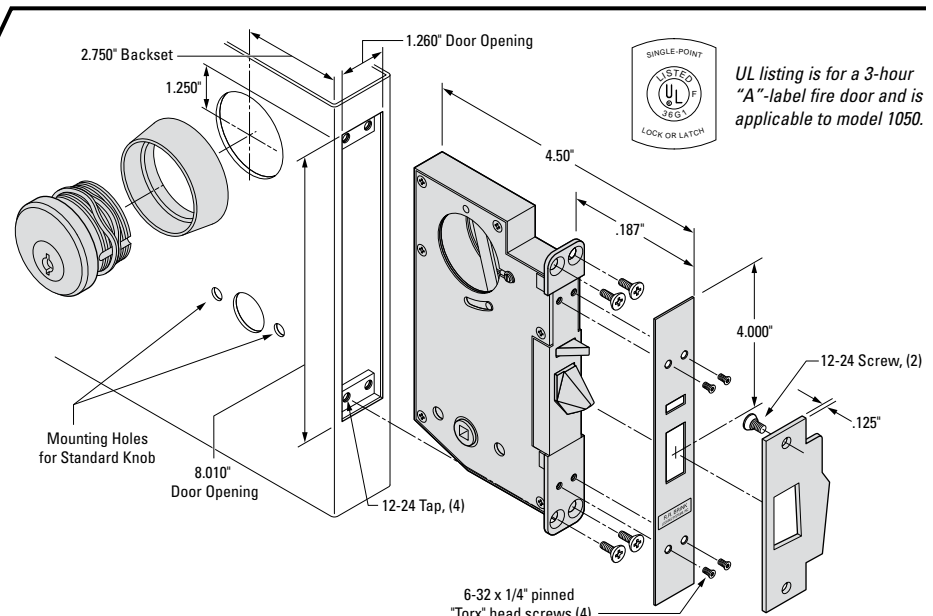

## R.R. BRINK LOCKING SYSTEMS, INC.

500 Earl Road • Shorewood, IL 60404  
 Tel: 815-744-7000 • Fax: 815-744-7020  
 www.rrbrink.com

# 1070

## Heavy Duty Mechanical Deadbolt Lock for Mortise Mount in Swinging Doors

Full 1" Bolt Throw – Hollow Metal Door Mortise Mounted



*Shown with builder's hardware mortise key cylinder.*

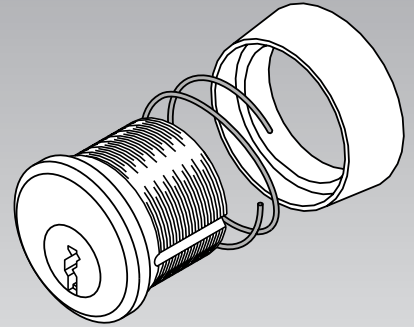

*RRBS proprietary "Mogul" (MOG) key cylinder can be specified.*

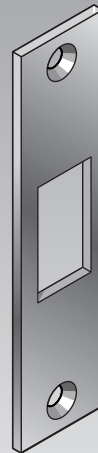

*Stainless steel strike plate.*



**R.R. BRINK LOCKING SYSTEMS, INC.**  
500 Earl Road • Shorewood, IL 60404  
Tel: 815-744-7000 • Fax: 815-744-7020  
www.rrbrink.com

### Application

The Model 1070 is a heavy duty deadbolt lock with a full one-inch bolt throw. It is recommended for hollow metal doors where latching (slam locking) is not a requirement. For example, this rugged deadlock is indicated for use in doors of plumbing chases, janitor and mechanical closets, and holding cells in detention facilities.

The Model 1070 lock case, front, and working parts are of stainless steel to meet the most demanding of security requirements. It is mortise mounted in a hollow metal door and can be keyed on one or two sides with an RRBS

six pin- tumbler Mogul cylinder or a high security commercial mortise key cylinder.

The key is removable only with the bolt fully retracted or projected (deadlocked), thus alerting the key holder to an impediment to the deadlocking of the bolt and, possibly, an attempt to breach security.

The handing of the Model 1070 is field adjustable, i.e. it is reversible according to door swing. The armor front is adjustable to match the degree of door edge bevel. A separate door knob or pull is recommended, such as those manufactured by R.R. Brink.

# 1070

## Heavy Duty Deadbolt Lock

### Construction Specification

- Lock case, armor front, springs, and working parts are of stainless steel.
- Fits ANSI mortise cutout – 1-1/4" x 8".
- Cast stainless steel bolt with a full 1" throw and two (2) saw resistant inserts.
- Stainless steel strike plate.
- Working parts made of copper alloy or stainless steel.
- Fitted for mechanical operation via either RRBSL proprietary "Mogul" or user's commercial key cylinder. (Factory supplied commercial key cylinder optional.)
- Exposed fasteners – pinned "Torx" head.
- Exposed Faceplate Metal Finish  
Satin Stainless Steel – (ANSI 630, US32D)

### Optional Features

- **Factory Key Cylinder** – (specify FKC and all keying information) – high security commercial key cylinder with "Yale" type cam. (Factory supplied commercial key cylinder optional.)
- **Mogul Cylinder** – (specify MOG and all keying information) – RRBSL proprietary six pin-tumbler "Mogul" key cylinder.
- **Thumb Turn** – (specify TP) - in lieu of "Mogul" or commercial key cylinder.

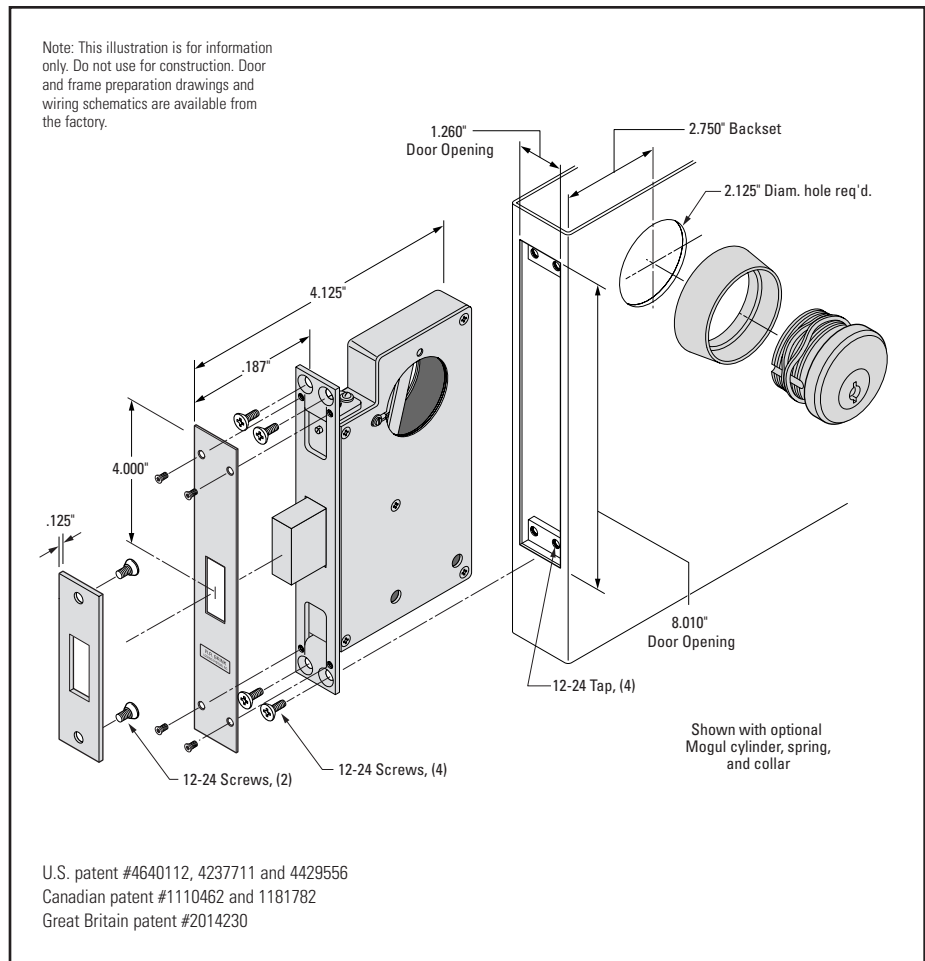

### Ordering Information

Model	Description
1072	1070 keyed one side
1076	1070 keyed both sides

### Custom Applications

Consult with our technical service personnel regarding custom applications such as retrofits to existing lock installations and special mounting conditions.

### Ordering Example

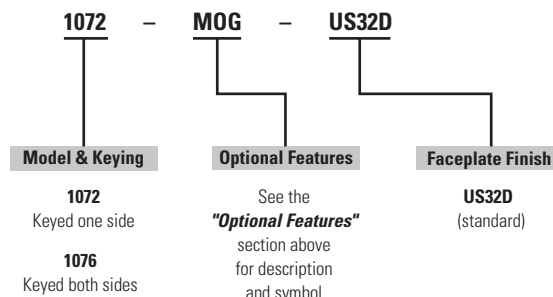

### R.R. BRINK LOCKING SYSTEMS, INC.

500 Earl Road • Shorewood, IL 60404  
Tel: 815-744-7000 • Fax: 815-744-7020  
www.rrbrink.com

# 2020

## Electromechanical Deadlocking Bolt

Solenoid actuated operation to lock (*Fail-safe*) or to unlock (*Fail-secure*) a door. Designed for hollow metal frame mounting. Available with a 3/4" throw stainless steel bolt.

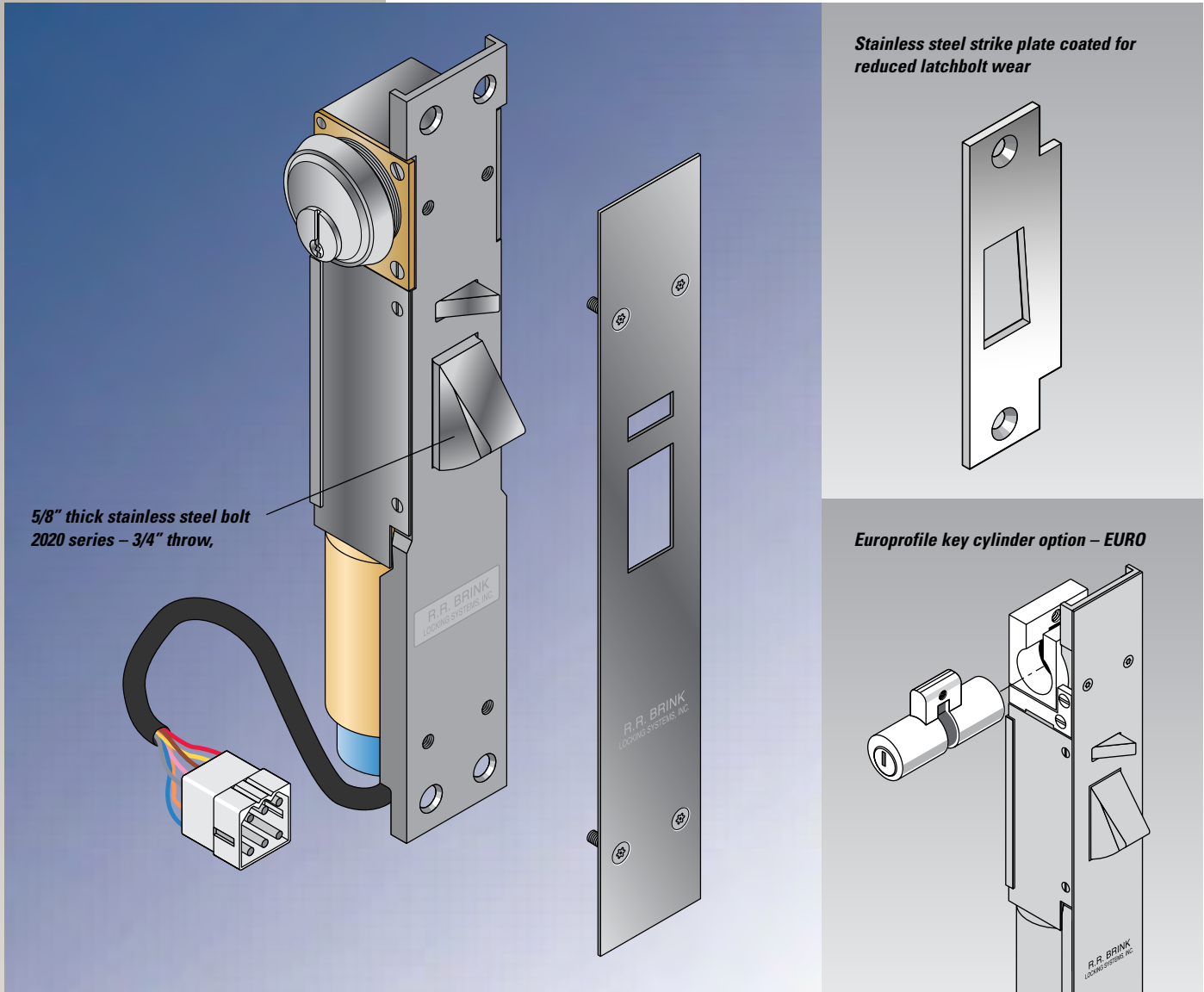

5/8" thick stainless steel bolt  
2020 series – 3/4" throw,

Stainless steel strike plate coated for  
reduced latchbolt wear

Europrofile key cylinder option – EURO



**R.R. BRINK LOCKING SYSTEMS, INC.**  
500 Earl Road • Shorewood, IL 60404  
Tel: 815-744-7000 • Fax: 815-744-7020  
www.rrbrink.com

### Application

- The 2020 series is ideal as an auxiliary or override lock for access control in secure areas of commercial, governmental, industrial, and institutional buildings.
- Available in "*Fail-safe*" (FS) (i.e. power to lock) or "*Fail-secure*" (FSE) (i.e. power to unlock) modes.
- The "*Fail-safe*" version is commonly used (with fire marshal approval) to secure an emergency exit required to have a panic exit device. For safety, the 2020 is connected to the building's fire detection system to effect automatic unlocking during an emergency. Also, a power failure would initiate unlocking.

- The 2020 has a 3/4" throw stainless steel bolt and narrow lock depth allowing mortise mounting in a standard (i.e. 2" trim) hollow metal door frame or an architectural metal tube (e.g. borrowed light frame mullion).
- Installation of the 2020 series is architecturally unobtrusive and affords superior impact and tamper resistance.

*Note: Unlocking of the "Fail-safe" and "Fail-secure" 2020 is by spring return and solenoid, respectively. A side force on the bolt will overcome these actions and prevent bolt retraction. Therefore, for proper operation, the bolt must be free of side loads.*

# 2020

## Electromechanical Deadlocking Bolt

Solenoid actuated operation to lock (*Fail-safe*) or to unlock (*Fail-secure*) a door. Model 2020 mounts in a standard hollow metal frame (i.e. 2" trim).

### Standard Features

- Structural and locking parts are stainless steel
- Non-working parts and fasteners of copper alloy or stainless steel
- 3/4" throw cast stainless steel bolt with two (2) saw resistant inserts
- Maintained Switch Latch Holdback (**MSLH**) function (see "Motor Lock Function Reference Guide" for other functions).
- Lock status switch (**LSS**) trips when latch is in deadlocked condition. Used in a signal circuit to indicate lock status – unlocked or deadlocked – via control panel lights and/or alarm devices. The LSS is also used to control an electrical interlock, which permits only one of a group of doors to be unlocked at any time. *Note: For positive, tamper resistant signaling of a closed and deadlocked door, a sensitive door position (DPS) switch must be wired in combination with the LSS. Our DPS Models 201030 or 201090 are recommended.*
- The stainless steel auxiliary (trigger) latch actuates a switch which, when the door is open, serves to hold the bolt retracted and preclude door closure on an extended bolt.
- Mechanical operation via customer supplied standard commercial key cylinder with "Yale" type cam. (Factory supplied key cylinder optional.) For two sided, frame keying see optional "key cylinder extension" (**KCE**).
- Plug connectors are provided for ease in wiring and removal.
- 24VDC cylindrical type constant duty solenoid with double wound coil – "Fail secure" (FSE) pull type and "Fail safe" push type (FS).
- Exposed fasteners – pinned "Torx" head
- Exposed Faceplate/ Strikeplate Finish  
Satin Stainless Steel (ANSI 630, US32D)

### Electrical Data

- Solenoid – Dual coil, continuous duty – 24VDC; 1.4 amp in-rush, 0.3 amp seated
- Lock Status Switch – 120/250VAC, 5 amp, SPDT (Form C)
- Bolt Hold Back Switch – 120/250VAC, 10 amp, SPDT (Form C)



**R.R. BRINK LOCKING SYSTEMS, INC.**  
500 Earl Road • Shorewood, IL 60404  
Tel: 815-744-7000 • Fax: 815-744-7020  
www.rrbrink.com

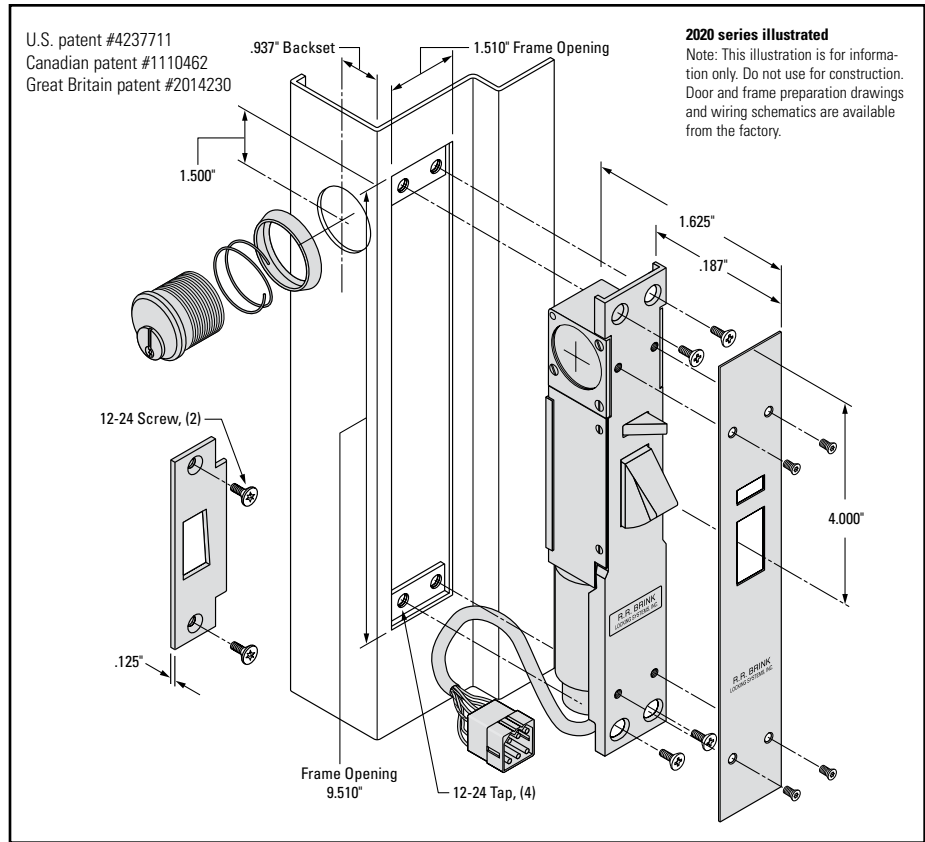

### Optional Features

- **FKC** – Factory supplied high security key cylinder with a tapered, free-spinning, spring loaded collar – two change keys/cylinder
- **KCE** – Stop (push) side key cylinder extension extends working length of a standard mortise key cylinder to adapt to jamb depths within a range of 4" to 9" (advise jamb depth dimension). Customer supplied cylinders shall be factory fitted to each KCE. Special fitting is required with non-Yale cam cylinders.
- **EURO** – Lock is adapted for key operation with an Europrofile cylinder – available with 25mm or 45mm backset.

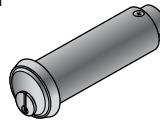

- **MLH** – Mechanical latch holdback by key – latch remains retracted with key removed – available with single side keying and FSE mode only – not available with EURO.
- **RC** – Rectifier with plug-in adapter permits 24VAC input

*Consult with our technical service personnel regarding custom applications such as retrofits to existing lock installations and special mounting situations.*

### Ordering Information – 2020 Electromechanical Series

Model	Description	Key Cylinder Extension (KCE)	Bolt Throw
2022	2020 keyed one side	Required if key cylinder is mounted on stop (push) side of frame	3/4"
2026	2020 keyed two sides	Required on stop (push) side of frame	3/4"

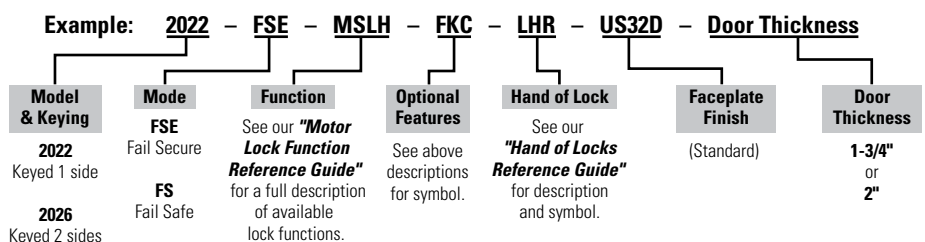

# 3020

## Electromechanical Automatic Deadlocking Latch

Electric 24VDC solenoid power and manual key unlocking. Designed to mount in a standard 2" deep hollow metal frame face.

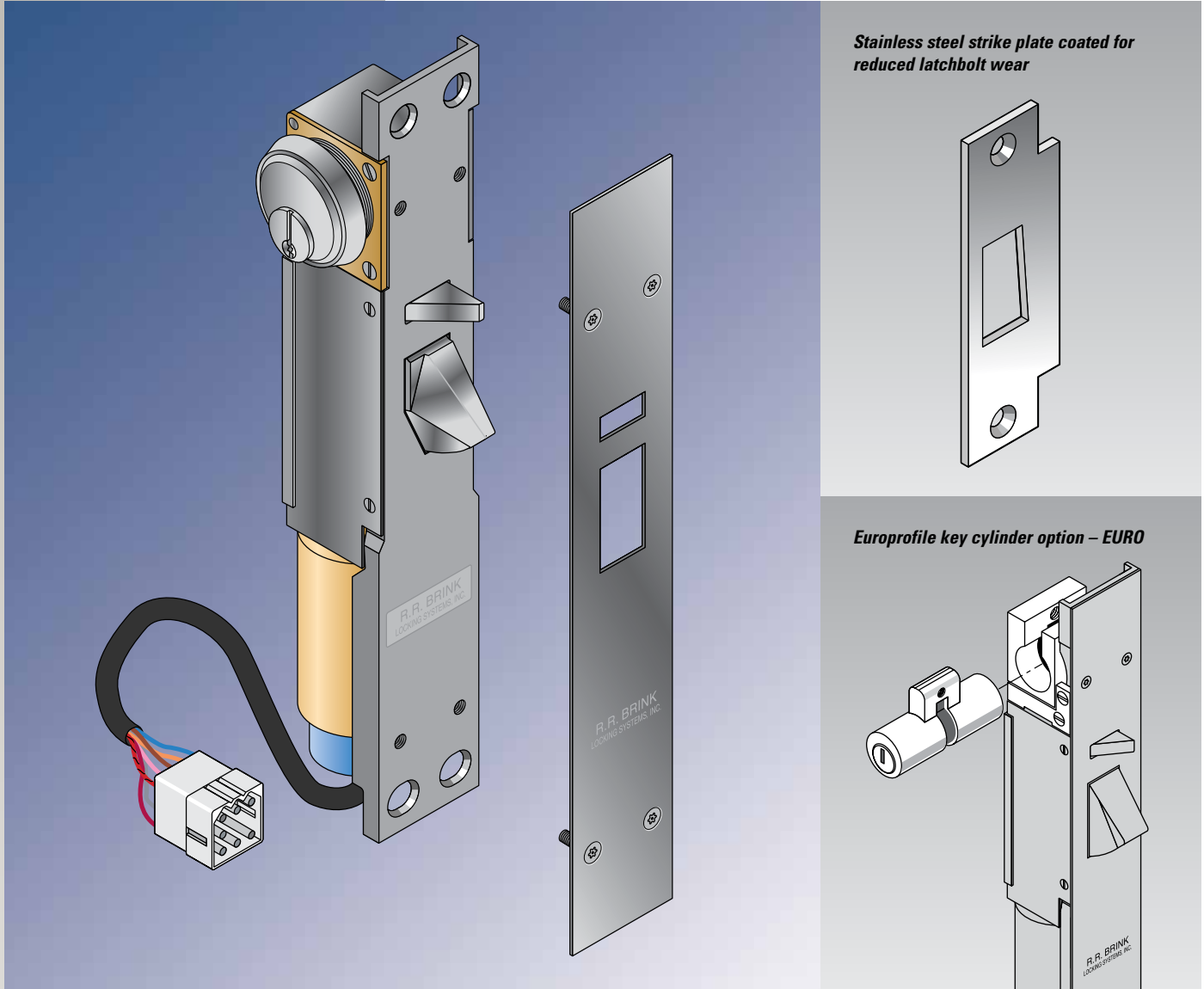

**R.R. BRINK LOCKING SYSTEMS, INC.**  
500 Earl Road • Shorewood, IL 60404  
Tel: 815-744-7000 • Fax: 815-744-7020  
www.rrbrink.com

### Application

- The 3020 is ideal for access control in secure areas of commercial, institutional, governmental, and industrial buildings.
- Available in "Fail secure" (FSE) (i.e. power to unlock) or "Fail safe" (FS) (i.e. power to lock) modes.
- Commonly used in minimum/medium security correctional facilities, the 3020 series provides remotely controlled electric and manual key unlocking of detention area sleeping room and exit doors.
- The narrow depth of the 3020 allows mortise mounting in a standard (i.e. 2" trim) hollow metal door frame or an architectural metal tube (e.g. borrowed

light frame mullion). The installation is architecturally unobtrusive and affords superior impact and tamper resistance.

- The 3020 is a higher security alternative to an electric strike for access control.
- Impact tested to Security Grade 1 per ASTM F1450 and F1577.

*(Note: The 3020 is not recommended for use in high security correctional locking applications and/or where latch retraction against a lateral load (e.g. leaning or pulling on the door) is a priority requirement. See our narrow profile lock models 3520-300 and 3520-600 for greater latch retraction force.)*

# 3020

## Electromechanical Automatic Deadlocking Latch

Electric 24VDC solenoid power and manual key unlocking. Designed to mount in a standard 2" deep hollow metal frame face.

### Standard Features

- Structural and locking parts are stainless steel.
- All other parts and fasteners are copper alloy or stainless steel.
- A full 3/4" throw cast stainless steel latch with two (2) saw resistant inserts.
- Maintained Switch Latch Holdback (**MSLH**) function (For other available functions, see catalog page "Function Guide for Motorized Locks", item 2 under "General Comments".)
- Lock status switch (**LSS**) trips when latch is in deadlocked condition. Used in a signal circuit to indicate lock status – unlocked or deadlocked – via control panel lights and/or alarm devices. The LSS is also used to control an electrical interlock which permits only one of a group of doors to be unlocked electrically at any time. Note: For positive, tamper resistant signaling of a closed and deadlocked door, a sensitive door position (**DPS**) switch must be wired in combination with the LSS. Our DPS Models 201030 or 201090 are recommended.
- Mechanical operation via customer supplied standard commercial key cylinder with "Yale" type cam. (Factory supplied key cylinder optional.) For stop (push) side frame keying see optional "Key Cylinder Extension" (**KCE**).
- Plug (i.e. quick disconnect) connectors are provided for ease in wiring and removal.
- 24VDC cylindrical type constant duty solenoid with double wound coil – "Fail secure" (**FSE**) pull type and "Fail Safe" (**FS**) push type.
- Exposed Fasteners – pinned "Torx" head
- Exposed Faceplate  
Satin Stainless Steel – (ANSI 630, US32D)

### Electrical Data

- Solenoid – Dual coil, continuous duty – 24VDC; 1.4 amp in-rush, 0.3 amp seated
- Lock Status Switch – 120/250VAC, 5 amp, SPDT (Form C)

U.S. patent #4237711  
Canadian patent #1110462  
Great Britain patent #2014230

Note: This illustration is for information only. Do not use for construction. Door and frame preparation drawings and wiring schematics are available from the factory.

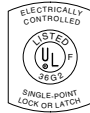

Underwriters Laboratories, Inc. listing as a fire door accessory applies to fail-secure mode only. Listing is for a 3-hour "A"-label fire door.

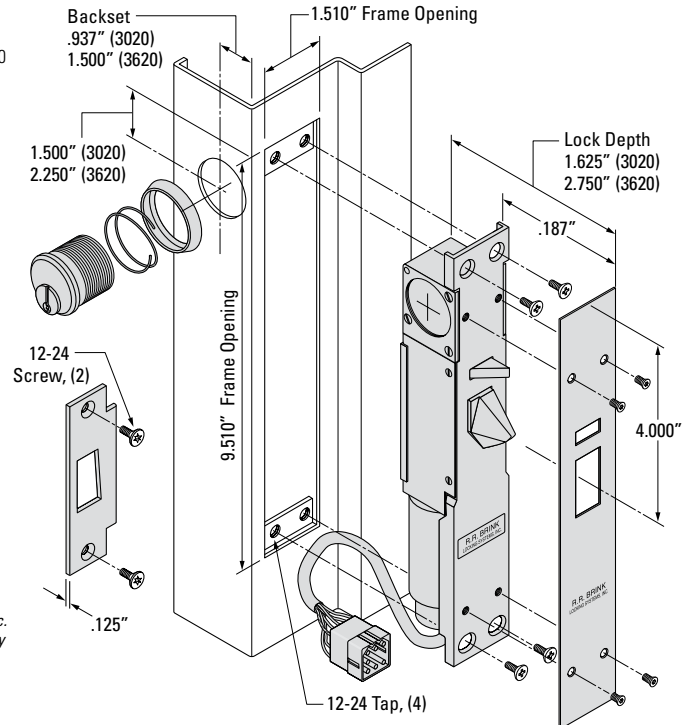

### Optional Features

- **FKC** – Factory supplied high security key cylinder with a tapered, free-spinning, spring loaded collar – two change keys/cylinder
- **MOG** – Supplied with RRBLS proprietary 2" diameter 6-pin cylinder. Model designation is 3620. Note: With this option, the lock requires a 3" minimum frame face.
- **EURO** – Lock is adapted for key operation with a Europrofile cylinder – available with 25mm or 45mm backset.
- **KCE** – Stop (push) side key cylinder extension extends working length of a standard mortise key cylinder to adapt to jamb depths within a range of 4" to 9" (advise jamb depth dimension). Customer supplied cylinders must be factory fitted to each KCE.
- **Electrical Functions (with FSE mode)**  
**MCLH-M, MCLH-E, and MSLH/MCLH-E** – (see notes 2 and 3 on "Motor Lock Function Reference Guide" catalog sheet.)
- **MLH** – Mechanical latch holdback by key – latch remains retracted with key removed –



available with single side keying and FSE mode only – not available with EURO.

- **CKS** – Factory key cylinder modification and an internal limit switch produce a key switch feature which electrically actuates the lock by one way only rotation of the change level key. This feature can be rendered inoperative by switch from a remote control panel. Mechanical unlocking is by a master level key. This feature is indicated when it is desirable to restrict periods when key unlocking is possible, e.g. building access or prison inmates who carry a key to their cell.
- **RC** – Rectifier with plug-in adapter permits 24VAC input

Consult with our technical service personnel regarding custom applications such as retrofits to existing lock installations and special mounting situations.

### Ordering Information – 3020 Solenoid Series

Model	Description	Key Cylinder Extension (KCE)
3022	3020 keyed one side	Required if key cylinder is mounted on stop (push) side of frame
3026	3020 keyed two sides	Required on stop (push) side of frame



**R.R. BRINK LOCKING SYSTEMS, INC.**  
500 Earl Road • Shorewood, IL 60404  
Tel: 815-744-7000 • Fax: 815-744-7020  
www.rrbrink.com

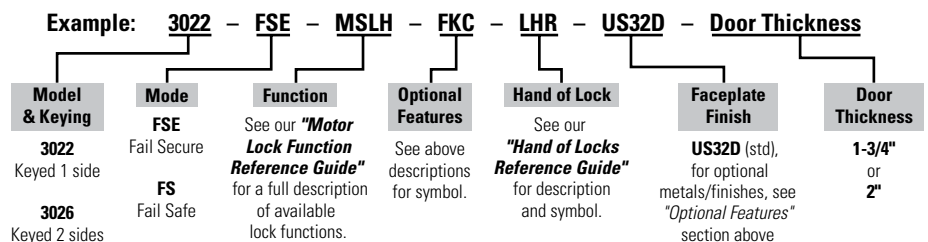



# 3520-300

## Motorized Deadlocking Latch

Narrow profile, designed for metal frame mounting in a standard jamb/header trim. The 24VDC motor drive retracts latch against side loads greater than 300 pounds.\*

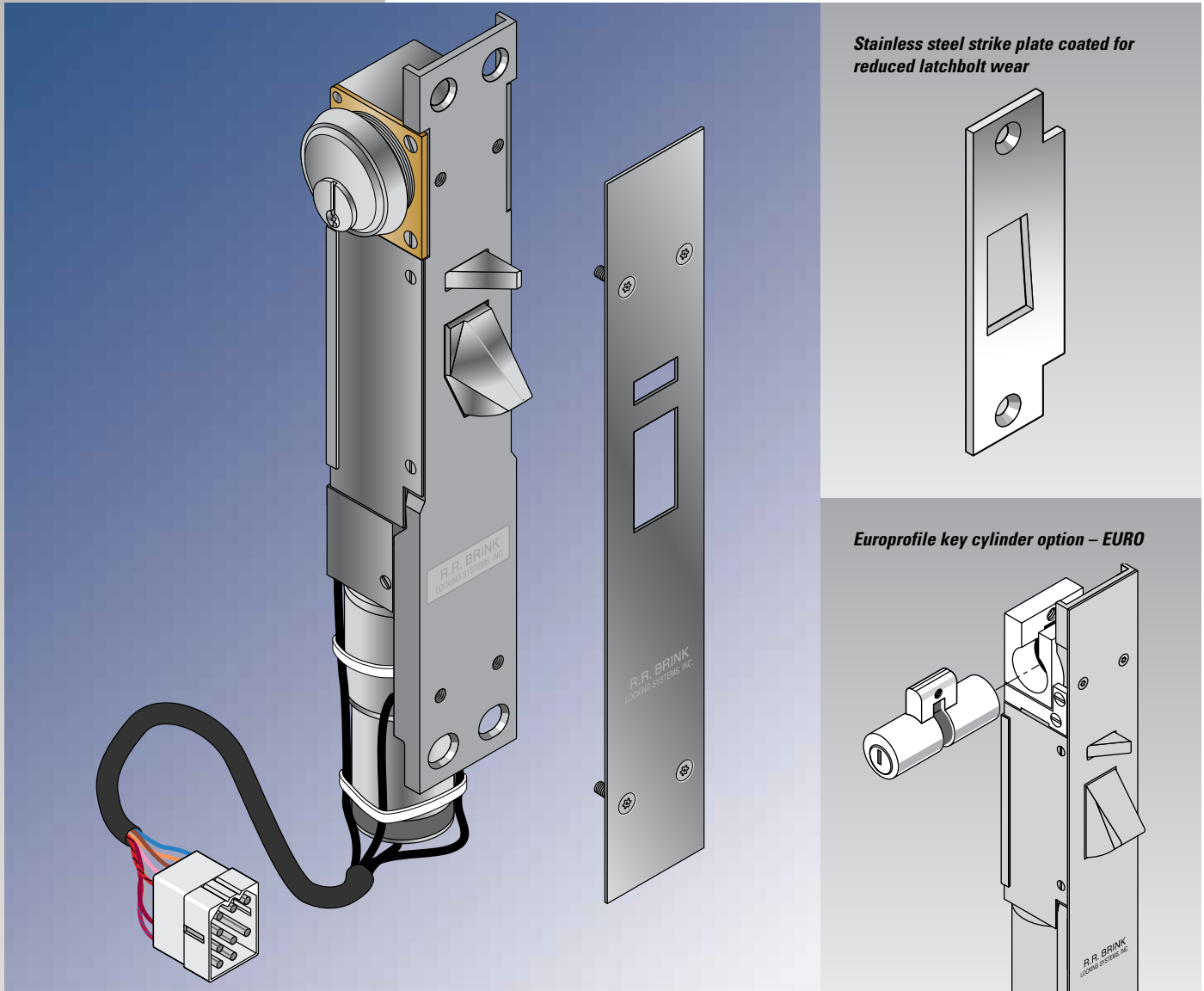

*Stainless steel strike plate coated for reduced latchbolt wear*

*Europrofile key cylinder option – EURO*



### **R.R. BRINK LOCKING SYSTEMS, INC.**

500 Earl Road • Shorewood, IL 60404  
Tel: 815-744-7000 • Fax: 815-744-7020  
www.rrbrink.com  
Email: rbrink@rrbrink.com

\* A side load remote bolt retraction test emulating the apparatus/procedure described in ASTM test F1577-05, Section 6.5 resulted in the 3520-300 bolt successfully retracting against a lateral load of 560 lbs. The test was witnessed by an independent testing laboratory - report available upon request.

### **Application**

- The 3520-300 is ideal for access control in secure areas of commercial, institutional, governmental, and industrial buildings.
- The 24VDC gearmotor facilitates remote unlocking even when an abnormally high  $\geq 300$  pound side force is applied against the latch.\*
- Available functions allow for electrical latch retraction and extension from a remote control point as well as manual key unlocking at the door.
- This lock is commonly used in medium security correctional facilities to provide remotely controlled electric unlocking of detention area sleeping room and exit doors.
- The narrow depth of the 3520-300 permits mortise mounting in a standard (i.e. 2" trim) hollow metal door frame or an architectural metal tube (e.g. borrowed light frame mullion).
- The 3520-300 is physically interchangeable with the RRBLS solenoid powered Model 3020 and, subject to wiring requirements, can be retrofitted to the latter.
- Installation of the 3520-300 is architecturally unobtrusive and affords superior impact and tamper resistance.
- Impact tested to Security Grade 1 per ASTM F1450 and F1577.

*(Note: Not recommended for maximum security detention applications.)*

# 3520-300

## Motorized Automatic Deadlocking Latch

Narrow profile, designed for metal frame mounting in a standard (i.e. 2" trim) jamb/header. The 24VDC gearmotor drive retracts the latch against side loads of  $\geq 300$  pounds.\*

### Standard Features

- Structural and locking parts are stainless steel
- All other parts and fasteners of copper alloy or stainless steel
- A full 3/4" throw cast stainless steel latch with two (2) saw resistant inserts.
- Maintained Switch Latch Holdback (**MSLH**) function (see "Motor Lock Function Reference Guide" for other functions).
- Lock status switch (**LSS**) trips when latch is in deadlocked condition. Used in a signal circuit to indicate lock status – unlocked or deadlocked – via control panel lights and/or alarm devices. The LSS is also used to control an electrical interlock, which permits only one of a group of doors to be unlocked at any time. Note: For positive, tamper resistant signaling of a closed and deadlocked door, a sensitive door position (**DPS**) switch must be wired in combination with the LSS. Our DPS Models 201030 or 201090 are recommended.
- Mechanical operation via customer supplied standard commercial key cylinder with "Yale" type cam. (Factory supplied key cylinder optional.) For stop (push) side frame keying see optional "key cylinder extension" (**KCE**).
- Plug connectors are provide for ease in wiring and removal.
- Exposed fasteners – pinned "Torx" head
- Exposed Faceplate  
Satin Stainless Steel – (ANSI 630, US32D)

### Electrical Data

- Gearmotor – Permanent magnet type – 1.0 ampere current limited at full load. Voltage must be 24VDC, +5% -10%. A regulated power supply is recommended for optimum performance.
- Lock Status Switch – 120/250VAC, 5 amp, SPDT (Form C)

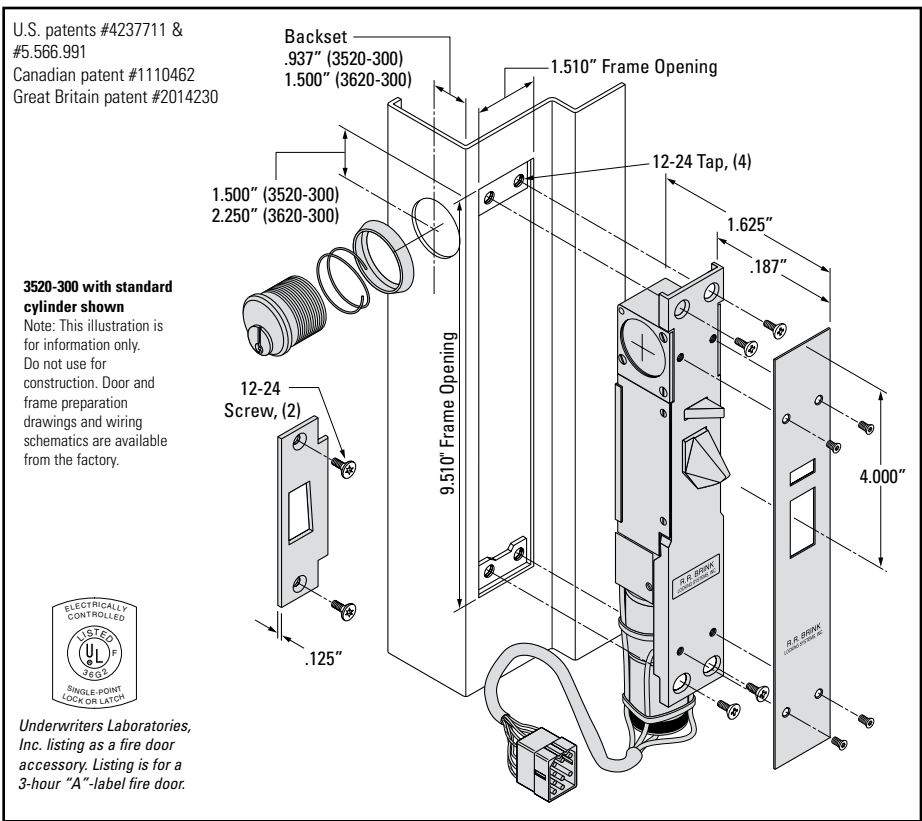

### Optional Features

- **FKC** – Factory supplied high security key cylinder with a tapered, free-spinning, spring loaded collar – two change keys/cylinder
- **MOG** – Supplied with RRBS proprietary 2" diameter 6-pin cylinder. Model designation is 3620-300. Note: With this option, the lock requires a 3" minimum frame face.
- **EURO** – Lock is adapted for key operation with a Europrofile cylinder – available with 25mm or 45mm backset.
- **KCE** – Stop (push) side key cylinder extension extends working length of a standard or mogul mortise key cylinder to adapt to jamb depths within a range of 4" to 9" (advise jamb depth dimension). Customer supplied cylinders must be factory fitted to each KCE.
- **MLH** – Mechanical latch holdback by key – latch remains retracted with key removed – available with single side keying only – not available with EURO or Mogul key cylinder.

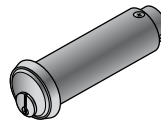

- **CKS** – Factory key cylinder modification and an internal limit switch produce a key switch feature which electrically actuates the lock by one way only rotation of the change level key. This feature can be rendered inoperative by switch from a remote control panel. Mechanical unlocking is by a master level key. This feature is indicated when it is desirable to restrict periods when key unlocking is possible, e.g. building access or prison inmates who carry a key to their cell.
- **RC** – Rectifier with plug-in adapter permits 24VAC input

Consult with our technical service personnel regarding custom applications such as retrofits to existing lock installations and special mounting situations.

### Ordering Information – 3520-300 Electromechanical Series

Model	Description	Key Cylinder Extension (KCE)
3522-300	3520-300 keyed one side	Required if key cylinder is mounted on stop (push) side of frame
3526-300	3520-300 keyed two sides	Required on stop (push) side of frame



**R.R. BRINK LOCKING SYSTEMS, INC.**  
500 Earl Road • Shorewood, IL 60404  
Tel: 815-744-7000 • Fax: 815-744-7020  
www.rrbrink.com

Example: 3522-300 – MSLH – FKC – LHR – US32D – Door Thickness					
Model & Keying	Function	Optional Features	Hand of Lock	Faceplate Finish	Door Thickness
3522-300 Keyed 1 side	See our "Motor Lock Function Reference Guide" for a full description of available lock functions.	See the "Optional Features" section above for description and symbol.	See our "Hand of Locks Reference Guide" for description and symbol.	US32D or US4 (std), for optional metals/finishes, see "Optional Features" section above	1-3/4" or 2"
3526-300 Keyed 2 sides					

# 3520-600

## Motorized Deadlocking Latch

Narrow profile design for jamb/header mounting in standard hollow metal frame. The 24VDC motor drive retracts latch against side loads greater than 600 pounds.\*

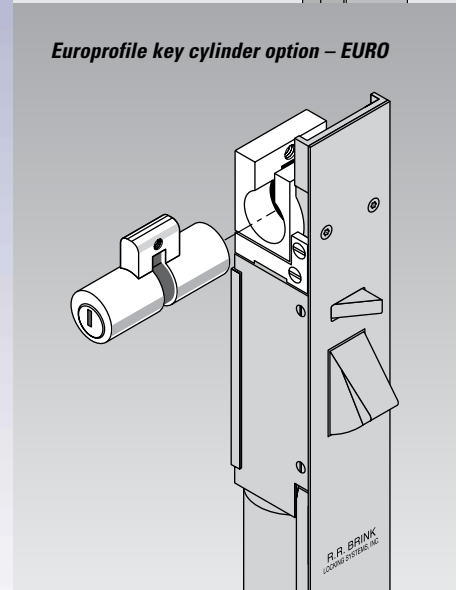
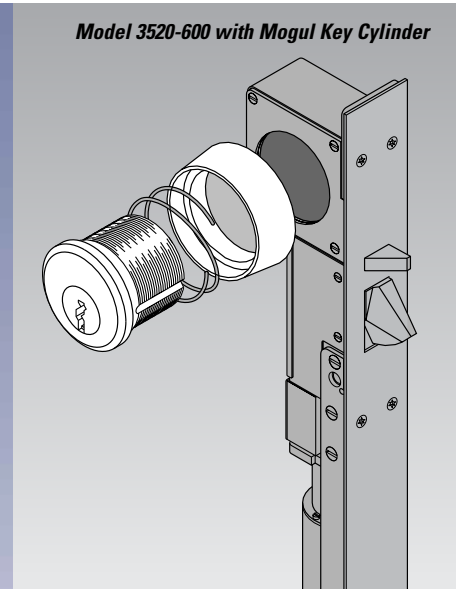
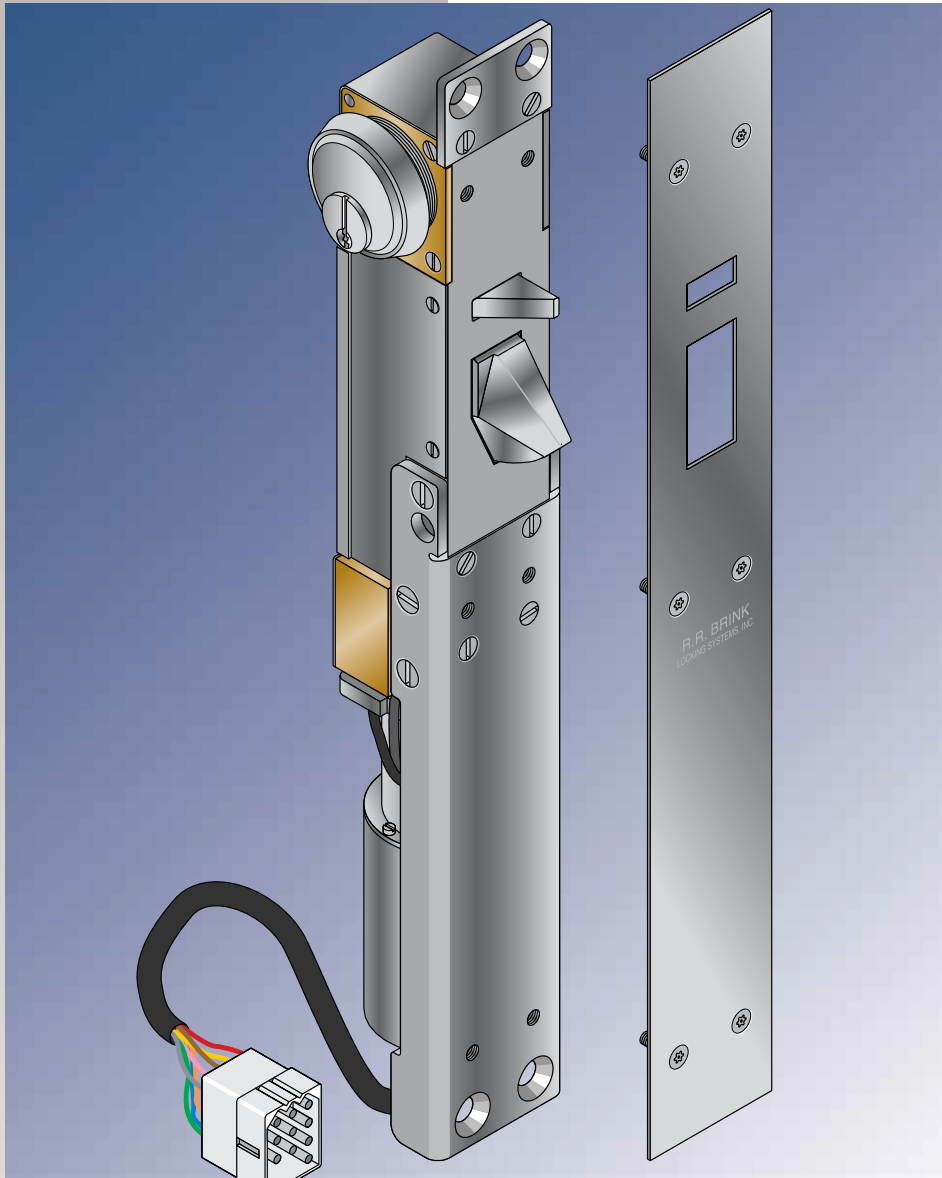

### R.R. BRINK LOCKING SYSTEMS, INC.

500 Earl Road • Shorewood, IL 60404  
Tel: 815-744-7000 • Fax: 815-744-7020  
www.rrink.com  
Email: rrink@rrbrink.com

\* A side load remote bolt retraction test emulating the apparatus/procedure described in ASTM test F1577-05, Section 6.5 resulted in the 3520-600 bolt successfully retracting against a lateral load of 1667 lbs. The test was witnessed by an independent testing laboratory - report available upon request.

### Application

- The 3520-600 series is ideal for access control in secure areas of commercial, industrial, governmental, and institutional buildings.
- The 24VDC gearmotor facilitates remote unlocking even when an abnormally high  $\geq 600$  pound side force is applied against the latch.\*
- Electrical functions allow for latch retraction and projection from a remote control point as well as manual key unlocking at the door.
- Commonly used in medium security correctional facilities to provide remotely

controlled electric unlocking of detention area sleeping room and exit doors.

- The narrow depth of the 3520-600 permits mortise mounting in a standard (i.e. 2" trim) hollow metal door frame or an architectural metal tube (e.g. borrowed light frame mullion).
- Impact tested to Security Grade 1 per ASTM F1450 and F1577.
- Installation of the 3520-600 is architecturally unobtrusive and affords superior impact and tamper resistance.

# 3520-600

## Motorized Deadlocking Latch

Narrow profile, designed for metal frame mounting in a standard (i.e. 2" trim) jamb/header. The 24VDC gearmotor drive retracts latch against side loads of ≥600 pounds.\*

### Standard Features

- Structural and locking parts are stainless steel.
- All other parts and fasteners are copper alloy or stainless steel.
- 3/4" throw cast stainless steel latch with two (2) saw resistant inserts.
- Maintained Switch Latch Holdback (**MSLH**) function (see "Motor Lock Function Reference Guide" for other functions).
- Lock status switch (**LSS**) trips when latch is in deadlocked condition. Used in a signal circuit to indicate lock status – unlocked or deadlocked – via control panel lights and/or alarm devices. The LSS is also used to control an electrical interlock, which permits only one of a group of doors to be unlocked at any time. *Note: For positive, tamper resistant signaling of a closed and deadlocked door, a sensitive door position (DPS) switch must be wired in combination with the LSS. Our DPS Models 201023 or 201030 are recommended.*
- Mechanical operation via customer supplied standard commercial key cylinder with "Yale" type cam. (Factory supplied key cylinder optional.) For stop (push) side frame keying see optional "Key Cylinder Extension" (**KCE**).
- Plug connectors for ease in wiring and removal.
- Exposed fasteners – pinned "Torx" head
- Exposed Faceplate  
Satin Stainless Steel – (ANSI 630, US32D)

### Electrical Data

- Gearmotor – Permanent magnet type – 1.0 ampere current limited at full load. Voltage must be 24VDC, +5% -10%. A regulated power supply is recommended for optimum performance.
- Lock Status Switch – 120/250VAC, 5 amp, SPDT (Form C)

U.S. patents #4237711 & #5,566,991  
Canadian patent #1110462  
Great Britain patent #2014230

### 3520-600 with standard cylinder shown

*Note: This illustration is for information only. Do not use for construction. Door and frame preparation drawings and wiring schematics are available from the factory.*



Underwriters Laboratories, Inc. listing as a fire door accessory. Listing is for a 3-hour "A"-label fire door.

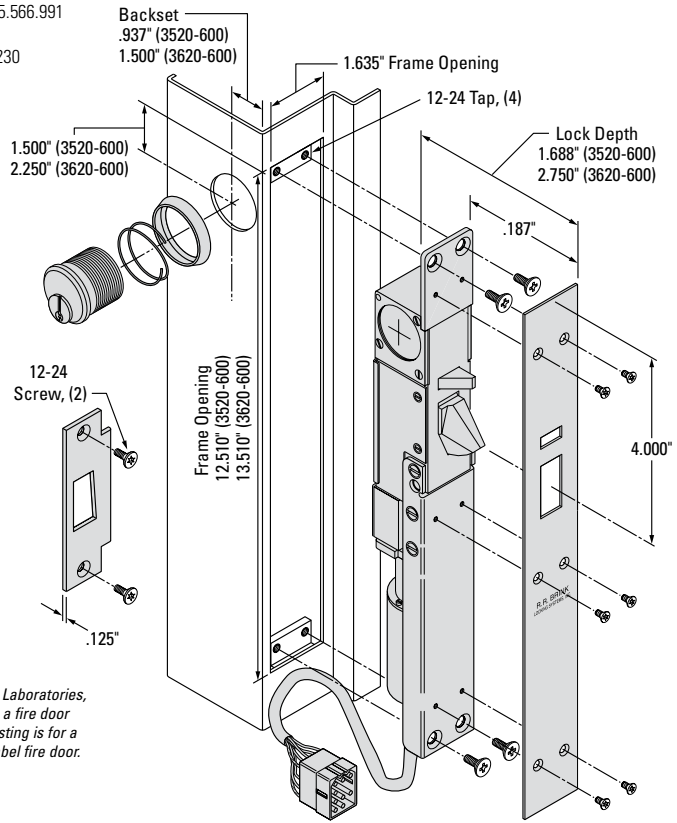

### Optional Features

- **FKC** – Factory supplied high security key cylinder with a tapered, free-spinning, spring loaded collar – two change keys/cylinder.
- **MOG** – Supplied with RRBLs proprietary 2" diameter 6-pin cylinder. *Note: With this option, the lock requires a 3" minimum frame face. Model designation is 3620-600.*
- **EURO** – Lock is adapted for key operation with an Europrofile cylinder – available with 25mm or 45mm backset.
- **KCE** – Stop (push) side key cylinder extension extends working length of a standard or mogul mortise key cylinder to adapt to jamb depths within a range of 4" to 9" (advise jamb depth dimension). Customer supplied cylinders must be factory fitted to each KCE.
- **MLH** – Mechanical latch holdback by key – latch remains retracted with key removed – available with single side keying only – not available with EURO or Mogul key cylinders.

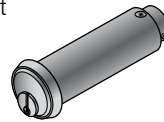

- **CKS** – Factory key cylinder modification and an internal limit switch produce a key switch feature which electrically actuates the lock by one way only rotation of the change level key. This feature can be rendered inoperative by switch from a remote control panel. Mechanical unlock-ing is by a master level key. This feature is indicated when it is desirable to restrict periods when key unlocking is possible, e.g. building access or prison inmates who carry a key to their cell.
- **RC** – Rectifier with plug-in adapter permits 24V AC input

Consult our technical service personnel regarding custom applications such as retrofits to existing lock installations and special mounting situations.

### Ordering Information – 3520-600 Electromechanical Series

Model	Description	Key Cylinder Extension (KCE)
3522-600	3520-600 keyed one side	Required if key cylinder is mounted on stop (push) side of frame
3526-600	3520-600 keyed two sides	Required on stop (push) side of frame



**R.R. BRINK LOCKING SYSTEMS, INC.**  
500 Earl Road • Shorewood, IL 60404  
Tel: 815-744-7000 • Fax: 815-744-7020  
www.rrbrink.com

Example: 3522-600 – MSLH – FKC – LHR – US32D – Door Thickness					
Model & Keying	Function	Optional Features	Hand of Lock	Faceplate Finish	Door Thickness
3522-600 Keyed 1 side	See our "Motor Lock Function Reference Guide" for a full description of available lock functions.	See the "Optional Features" section above for description and symbol.	See our "Hand of Locks Reference Guide" for description and symbol.	US32D Satin Stainless Steel (ANSI 630)	1-3/4" or 2"
3526-600 Keyed 2 sides					

# 3620-300

## Motorized Deadlocking Latch with Mogul Key Cylinder

Narrow profile, designed for metal frame mounting in a 3" trim jamb/header. The 24VDC motor drive retracts latch against side loads of 300 pounds.



### Application

- The 3620-300 is ideal for access control in secure areas of commercial, institutional, governmental, and industrial buildings.
- The 24VDC gearmotor achieves remote unlocking even when an abnormally high 300 pound side force is applied against the latch.
- Available functions allow for electrical latch retraction and extension from a remote control point as well as manual key unlocking at the door.
- Standard with RRBSL 2" diameter detention grade Mogul cylinder. Workable with 2" diameter builders' hardware brands. See "Key Cylinders" catalog page for elaboration.
- This lock is commonly used in medium security correctional facilities to provide remotely controlled electric unlocking of detention area sleeping room and exit doors.

*(Note: Not recommended for maximum security detention applications.)*

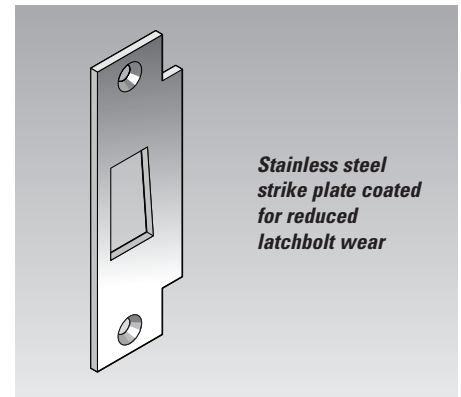

**R.R. BRINK LOCKING SYSTEMS, INC.**

500 Earl Road • Shorewood, IL 60404  
Tel: 815-744-7000 • Fax: 815-744-7020  
www.rrbrink.com

# 3620-300

## Motorized Automatic Deadlocking Latch with Mogul Key Cylinder

Narrow profile, designed for metal frame mounting in a 3" trim jamb/header. The 24VDC gearmotor drive retracts the latch against side loads of 300 pounds.

### Standard Features

- Structural and locking parts are stainless steel
- All other parts and fasteners of copper alloy or stainless steel
- A full 3/4" throw cast stainless steel latch with two (2) saw resistant inserts.
- Standard with RRBL5 2" diameter detention grade Mogul cylinder. Workable with 2" diameter builders' hardware brands. See "Key Cylinders" catalog page for elaboration.
- Maintained Switch Latch Holdback (**MSLH**) function (see "Motor Lock Function Reference Guide" for other functions).
- Lock status switch (**LSS**) trips when latch is in deadlocked condition. Used in a signal circuit to indicate lock status – unlocked or deadlocked – via control panel lights and/or alarm devices. The LSS is also used to control an electrical interlock, which permits only one of a group of doors to be unlocked at any time. *Note: For positive, tamper resistant signaling of a closed and deadlocked door, a sensitive door position (DPS) switch must be wired in combination with the LSS. Our DPS Models 201030 or 201090 are recommended.*

- For stop (push) side frame keying see optional "key cylinder extension" (**KCE**).
- Plug connectors are provided for ease in wiring and removal.
- Exposed fasteners – pinned "Torx" head
- Exposed Faceplate  
Satin Stainless Steel – (ANSI 630, US32D)

### Electrical Data

- Gearmotor – Permanent magnet type – 1.0 ampere current limited at full load. Voltage must be 24VDC, +5% -10%. A regulated power supply is recommended for optimum performance.
- Lock Status Switch – 120/250VAC, 5 amp, SPDT (Form C)

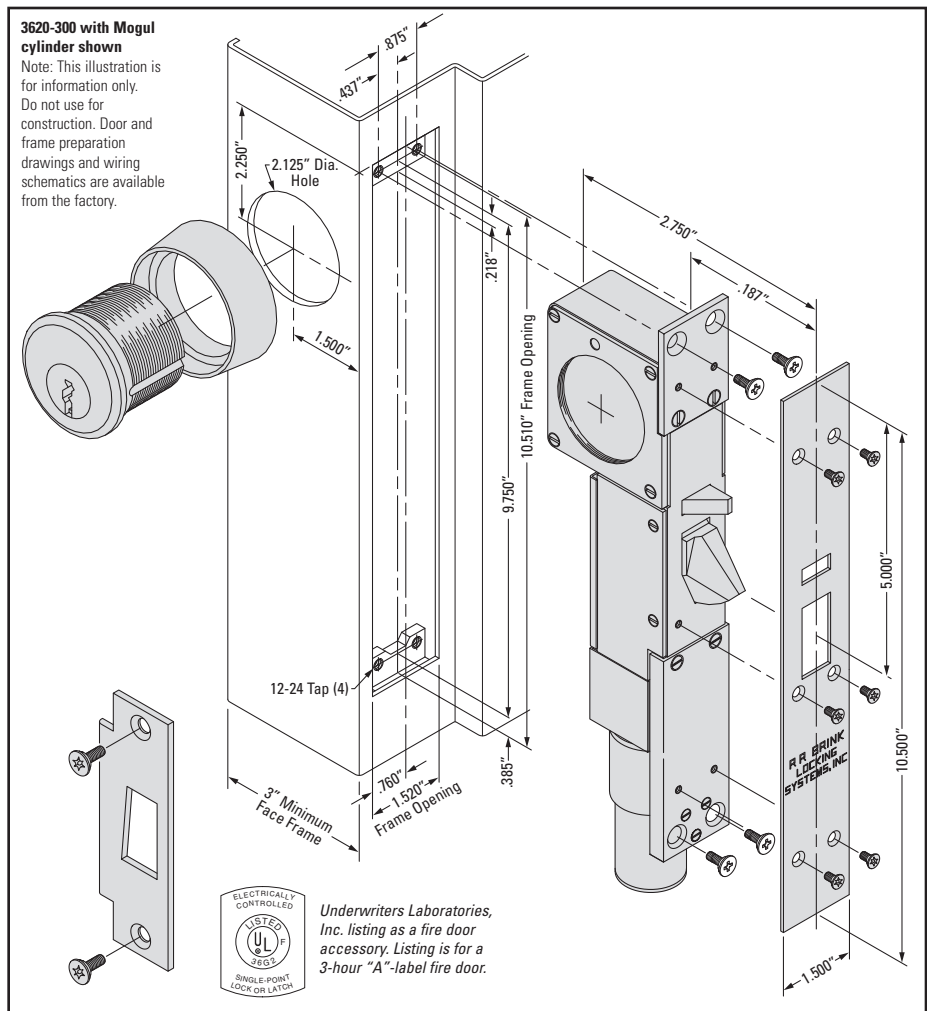

### Optional Features

- **KCE** – Stop (push) side key cylinder extension extends working length of a standard or mogul mortise key cylinder to adapt to jamb depths within a range of 4" to 9" (advise jamb depth dimension). Customer supplied cylinders must be factory fitted to each KCE.
- **CKS** – Factory key cylinder modification and an internal limit switch produce a key switch feature which electrically actuates the lock by one way only rotation of the change level key. This feature can be rendered inoperative by switch from a remote control panel. Mechanical

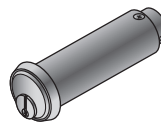

unlocking is by a master level key. This feature is indicated when it is desirable to restrict periods when key unlocking is possible, e.g. building access or prison inmates who carry a key to their cell.

- **RC** – Rectifier with plug-in adapter permits 24VAC input

Consult with our technical service personnel regarding custom applications such as retrofits to existing lock installations and special mounting situations.

### Ordering Information – 3620-300 Electromechanical Series

Model	Description	Key Cylinder Extension (KCE)
3622-300	3620-300 keyed one side	Required if key cylinder is mounted on stop (push) side of frame
3626-300	3620-300 keyed two sides	Required on stop (push) side of frame



**R.R. BRINK LOCKING SYSTEMS, INC.**  
 500 Earl Road • Shorewood, IL 60404  
 Tel: 815-744-7000 • Fax: 815-744-7020  
 www.rrbrink.com

**Example: 3622-300 – MSLH – KCE – LHR – US32D – Door Thickness**

Model & Key Code(s)	Function	Optional Features	Hand of Lock	Faceplate Finish	Door Thickness
3622-300 Keyed 1 side	See our "Motor Lock Function Reference Guide" for a full description of available lock functions.	See the "Optional Features" section above for description and symbol.	See our "Hand of Locks Reference Guide" for description and symbol.	US32D Satin Stainless Steel (ANSI 630)	1-3/4" or 2"
3626-300 Keyed 2 sides					

# 3620-600

## Motorized Deadlocking Latch with Mogul Key Cylinder

Narrow profile, designed for metal frame mounting in a 3" trim jamb/header. The 24VDC motor drive retracts latch against side loads of 600 pounds.



### Application

- The 3620-600 series is ideal for access control in secure areas of commercial, industrial, governmental, and institutional buildings.
- The 24VDC motor facilitates remote unlocking even when an abnormally high 600 pound side force is applied against the latch.
- Electrical functions allow for latch retraction and projection from a remote control point as well as manual key unlocking at the door.
- Standard with RRBS 2" diameter detention grade Mogul cylinder. Workable with 2" diameter builders' hardware brands. See "Key Cylinders" catalog page for elaboration.
- Commonly used in medium security correctional facilities to provide remotely controlled electric unlocking of detention area sleeping room and exit doors.
- Impact tested to Security Grade 1 per ASTM F1450 and F1577.
- Installation of the 3620-600 is architecturally unobtrusive and affords superior impact and tamper resistance.

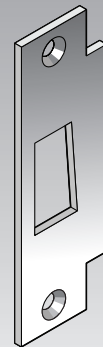

**Stainless steel  
strike plate coated  
for reduced  
latchbolt wear**

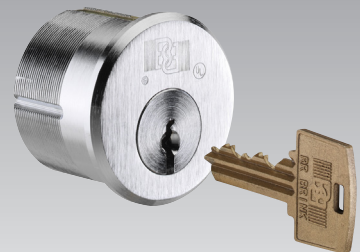

**RRBS Mogul Cylinder and Key Standard**



**R.R. BRINK LOCKING SYSTEMS, INC.**

500 Earl Road • Shorewood, IL 60404  
Tel: 815-744-7000 • Fax: 815-744-7020  
www.rrbrink.com

# 3620-600

## Motorized Deadlocking Latch with Mogul Key Cylinder

Narrow profile, designed for metal frame mounting in a standard 3" trim jamb/ header. The 24VDC motor drive retracts latch against side loads of 600 pounds.

### Standard Features

- Structural and locking parts are stainless steel.
- All other parts and fasteners are copper alloy or stainless steel.
- 3/4" throw cast stainless steel latch with two (2) saw resistant inserts.
- Standard with RRBLS 2" diameter detention grade Mogul cylinder. Workable with 2" diameter builders' hardware brands. See "Key Cylinders" catalog page for elaboration.
- Maintained Switch Latch Holdback (**MSLH**) function (see "Motor Lock Function Reference Guide" for other functions).
- Lock status switch (**LSS**) trips when latch is in deadlocked condition. Used in a signal circuit to indicate lock status – unlocked or deadlocked – via control panel lights and/or alarm devices. The LSS is also used to control an electrical interlock, which permits only one of a group of doors to be unlocked at any time. *Note: For positive, tamper resistant signaling of a closed and deadlocked door, a sensitive door position (DPS) switch must be wired in combination with the LSS. Our DPS Models 201023 or 201030 are recommended.*
- For stop (push) side frame keying see optional "Key Cylinder Extension" (**KCE**).
- Plug connectors for ease in wiring and removal.
- Exposed fasteners – pinned "Torx" head
- Exposed Faceplate  
Satin Stainless Steel – (ANSI 630, US32D)

### Electrical Data

- Gearmotor – Permanent magnet type – 1.0 ampere current limited at full load. Voltage must be 24VDC, +5% -10%. A regulated power supply is recommended for optimum performance.
- Lock Status Switch – 120/250VAC, 5 amp, SPDT (Form C)

### 3620-600 with Mogul cylinder shown

Note: This illustration is for information only. Do not use for construction. Door and frame preparation drawings and wiring schematics are available from the factory.

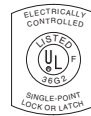
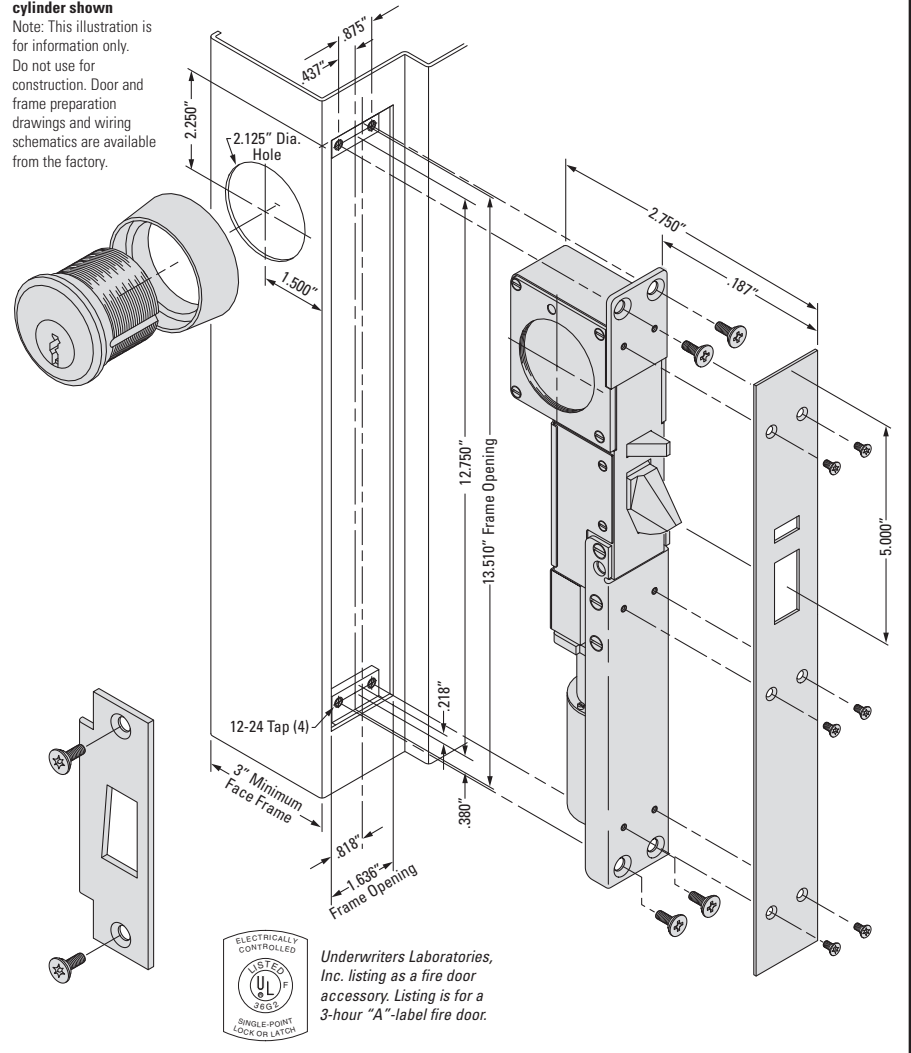

Underwriters Laboratories, Inc. listing as a fire door accessory. Listing is for a 3-hour "A"-label fire door.

### Optional Features

- **KCE** – Stop (push) side key cylinder extension extends working length of a standard or mogul mortise key cylinder to adapt to jamb depths within a range of 4" to 9" (advise jamb depth dimension). Customer supplied cylinders must be factory fitted to each KCE.
- **CKS** – Factory key cylinder modification and an internal limit switch produce a key switch feature which electrically actuates the lock by one way only rotation of the change level key. This feature can be rendered inoperative by switch from a remote control panel. Mechanical unlock-

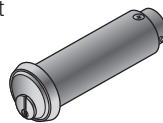

ing is by a master level key. This feature is indicated when it is desirable to restrict periods when key unlocking is possible, e.g. building access or prison inmates who carry a key to their cell.

- **RC** – Rectifier with plug-in adapter permits 24VAC input

Consult our technical service personnel regarding custom applications such as retrofits to existing lock installations and special mounting situations.

### Ordering Information – 3620-600 Electromechanical Series

Model	Description	Key Cylinder Extension (KCE)
3622-600	3620-600 keyed one side	Required if key cylinder is mounted on stop (push) side of frame
3626-600	3620-600 keyed two sides	Required on stop (push) side of frame



**R.R. BRINK LOCKING SYSTEMS, INC.**  
500 Earl Road • Shorewood, IL 60404  
Tel: 815-744-7000 • Fax: 815-744-7020  
www.rrbrink.com

Model & Key Code(s)	Function	Optional Features	Hand of Lock	Faceplate Finish	Door Thickness
3622-600 Keyed 1 side	See our "Motor Lock Function Reference Guide" for a full description of available lock functions.	See the "Optional Features" section above for description and symbol.	See our "Hand of Locks Reference Guide" for description and symbol.	US32D Satin Stainless Steel (ANSI 630)	1-3/4" or 2"
3626-600 Keyed 2 sides					



# AC5020 EUKL

## Electromechanical Automatic Deadlocking Bolt High Security and Impact Resistant – 1" Throw

120VAC Solenoid Actuated and Manual Key Unlocking – Jamb Mounted



*Hinge-Side (Pull)  
Frame Mounting*

Locate removable  
cover plate on  
non-secure side  
of frame

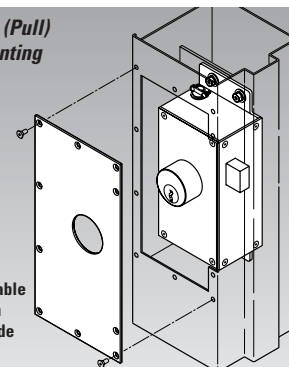

*Stop-Side (Push)  
Frame Mounting  
with KCE*

Locate removable  
cover plate on  
non-secure side  
of frame

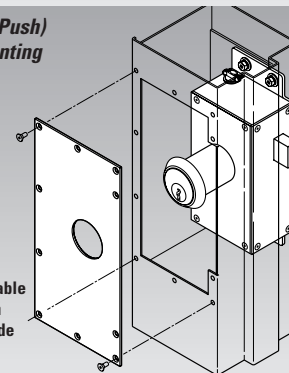

*Stop-Side (Push)  
Frame Mounting  
with Pocket*

Locate  
removable  
cover plate on  
non-secure  
side of frame

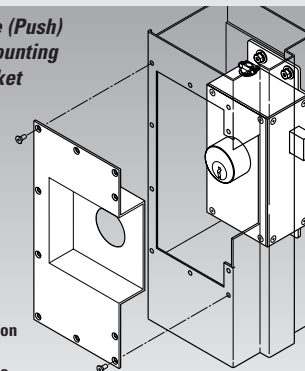

### R.R. BRINK LOCKING SYSTEMS, INC.

500 Earl Road • Shorewood, IL 60404  
Tel: 815-744-7000 • Fax: 815-744-7020  
www.rrbrink.com

### Application

- The 5020 EUKL is an electromechanical deadbolt used primarily to secure emergency exit doors which are normally locked.
- Unlocking can be initiated by a remotely located switch and/or automatically (e.g. actuation of a fire alarm). When unlocked electrically, the 5020 EUKL must be relocked manually by key at the door (i.e. electric unlock, key lock). This feature precludes inadvertent or intentional locking of a means of egress during an emergency situation.
- Electric unlocking is accomplished by a 120VAC solenoid actuator. Deadbolt retraction is quick and accompanied by a noticeable clap sound.
- Mechanical deadbolt retraction by pin tumbler key cylinder – commercial or “Prison Mogul” types.
- The Model 5020 EUKL normally is jamb mounted in a steel door frame (14 gauge minimum) in a specially fabricated and reinforced lock pocket (or mortar box).
- Impact tested to Security Grade 1 per ASTM F1450 and F1577.
- When used in exterior locations, moisture proofing of the lock enclosure is essential and an internal resistance heating strip is recommended when the lock may be subjected to extreme freezing conditions.

# AC5020 EUKL

## Electromechanical Automatic Deadlocking Bolt – 1" Throw High Security/Impact Resistant

120 VAC solenoid actuated and manual key unlocking via standard or Mogul key cylinder – jamb mounted

### Standard Features

- Lock case and made cover of 10 gauge steel, electroplated for corrosion resistance
- Bolt made of saw-resistant hardened steel with a full 1" throw and 3/4" x 1-1/2" cross section.
- Cast stainless steel strike plate.
- Working parts are high strength bronze or stainless steel.
- Lock status switch (**LSS**) trips when the bolt is in a deadlocked condition. Used in a signal circuit to indicate lock status – unlocked or deadlocked – via control panel lights and/or alarm devices. *Note: For positive, tamper resistant signaling of a closed and deadlocked door, a sensitive door position (DPS) switch must be wired in combination with the LSS. Our DPS Nos. 201030 or 201090 are recommended.*
- Fitted for mechanical operation via either RRBLs proprietary "Mogul" or user's commercial key cylinder. (Factory supplied commercial key cylinder optional.) For stop side only or both side frame keying, the frame manufacturer must provide stop (push) side cylinder access or optional "key cylinder extension" (**KCE**). Key cylinder(s) must be factory assembled in lock.
- Available cylinder finishes – Satin Brass (ANSI 606, US4) or Chrome (ANSI 626, US26D)
- Plug connectors are provided for ease in wiring and removal.
- Exposed fasteners – pinned "Torx" head

### Electrical Data

- Solenoid – 120VAC – 10 ampere in-rush, 0.75 ampere seated
- Lock Status Switch – 125/250VAC, 5 amp, SPDT (Form C)

### 5022 EUKL Illustrated

Typical hinge (pull) side mounting shown.

Note: This illustration is for information only. Do not use for construction. Door and frame preparation drawings and wiring schematics are available from the factory.

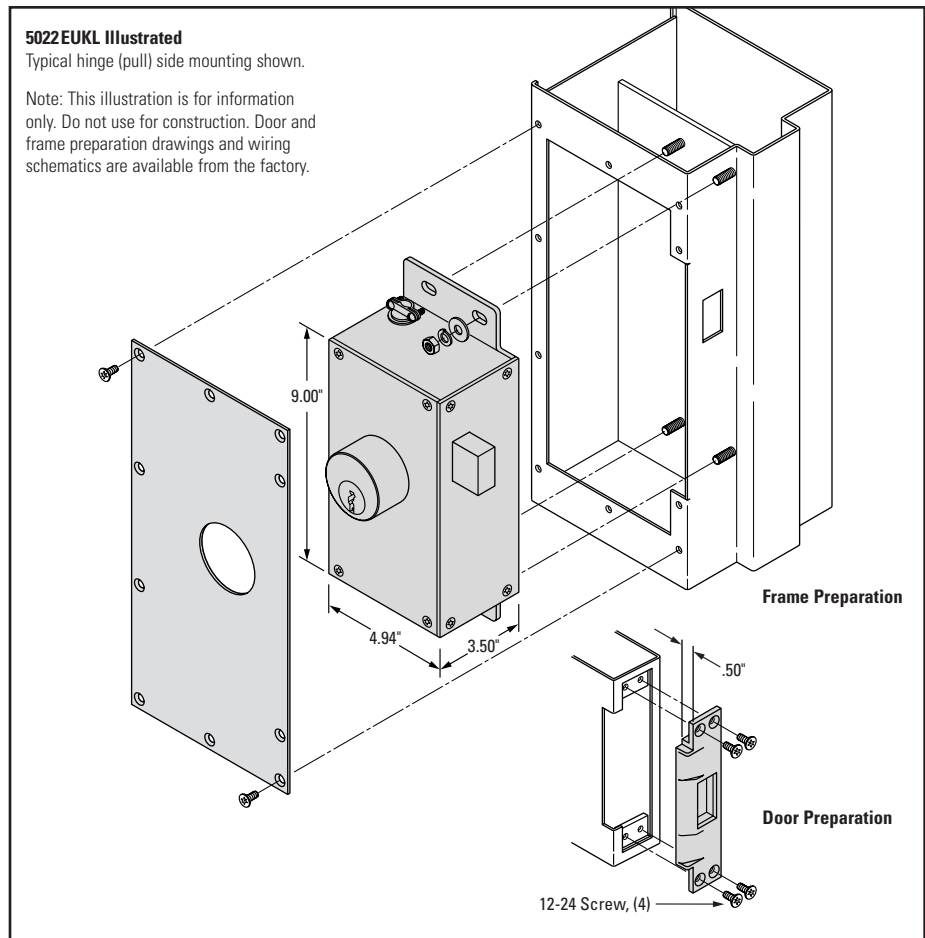

### Optional Features

- **FKC** – Factory supplied high security commercial key cylinder with collar – two change keys/cylinder
- **MOG** – Supplied with RRBLs Mogul proprietary 2" diameter 6-pin cylinder. UL listed locking cylinder (UL-437). Keys are ordered separately.
- **KCE** – In lieu of a conventional stop (push) side key cylinder access opening in the frame, a key cylinder extension extends



the working length of a commercial or Mogul key cylinder to adapt to outside jamb depths. This option applies to one side stop or both side keying only. Customer supplied cylinders must be factory fitted to each KCE. (Jamb depth dimension required with order.)

### Ordering Information

#### 5020 EUKL – Solenoid Actuated Series

Model	Description
5021 EUKL	5020 EUKL keyed stop side only
5022 EUKL	5020 EUKL keyed hinge side only
5026 EUKL	5020 EUKL keyed both sides

Consult with our technical service personnel regarding custom applications such as retrofits to existing lock installations and special mounting situations.

#### Example: 5026 EUKL – FKC – LHR – Hinge-Side (PULL) – US26D

#### Model & Keying

5021 EUKL  
Keyed stop side  
5022 EUKL  
Keyed hinge side  
5026 EUKL  
Keyed both sides

#### Optional Features

See the "Optional Features" section above for description and symbol.

#### Hand of Lock

See our "Hand of Locks Reference Guide" for description and symbol.

#### Removable Cover Plate Frame Side

Hinge-Side (PULL)  
Stop-Side (PUSH)

#### Key Cylinder Finish

US4 or US26D (standard)



### R.R. BRINK LOCKING SYSTEMS, INC.

500 Earl Road • Shorewood, IL 60404  
Tel: 815-744-7000 • Fax: 815-744-7020  
www.rrbrink.com

# AC5020M

## Electromechanical 1" Throw Automatic Deadlocking Latch – High Security and Impact Resistant

24 VDC or 120 VAC Motor Power and Manual Key Unlocking – Jamb Mounted



Cast stainless steel strike plate

### Hinge-Side (Pull) Frame Mounting

Locate removable cover plate on non-secure side of frame

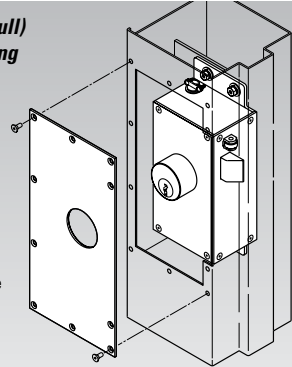

### Stop-Side (Push) Frame Mounting with KCE

Locate removable cover plate on non-secure side of frame

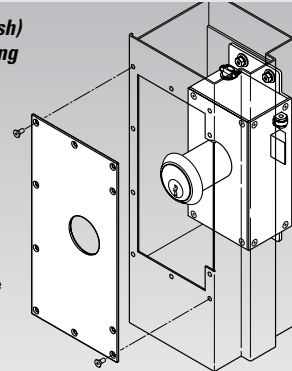

### Stop-Side (Push) Frame Mounting with Pocket

Locate removable cover plate on non-secure side of frame

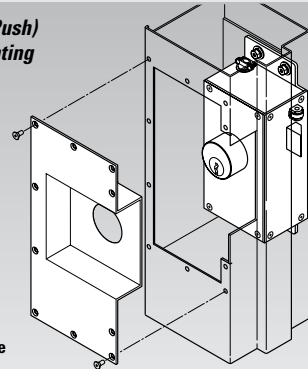

**R.R. BRINK LOCKING SYSTEMS, INC.**  
500 Earl Road • Shorewood, IL 60404  
Tel: 815-744-7000 • Fax: 815-744-7020  
www.rrbrink.com

### Application

- The 5020M is widely used in medium and maximum security detention facilities for remotely controlled electric unlocking of inmate room and passage doors.
- This lock is ideal as a component in attack resistant security perimeters in sensitive areas of commercial, governmental, and industrial buildings.
- Electric unlocking is by either 24VDC or 120VAC motor. Latch retraction is quiet and capable of overcoming abnormally high side loads (e.g. someone leaning or pulling on the door to prevent unlocking).
- Mechanical latch retraction by pin tumbler key cylinder—commercial size or “Prison Mogul” types.
- The Model 5020M normally is jamb mounted in a steel door frame (14 gauge recommended minimum) in a specially fabricated and reinforced lock pocket (or mortar box).
- The lock mechanism can be accessed without removal from the frame via an access plate on the non-secure side of the frame.
- Impact tested to Security Grade 1 per ASTM F1450 and F1577.
- When used in exterior locations, moisture proofing of the lock enclosure is essential and an internal resistance heating strip is recommended when the lock may be subjected to extreme freezing conditions.

# AC5020M

## Electromechanical 1" Throw Automatic Deadlocking Latch High Security/Impact Resistant

24 VDC or 120 VAC Motor Power and Manual Key Unlocking – Jamb Mounted

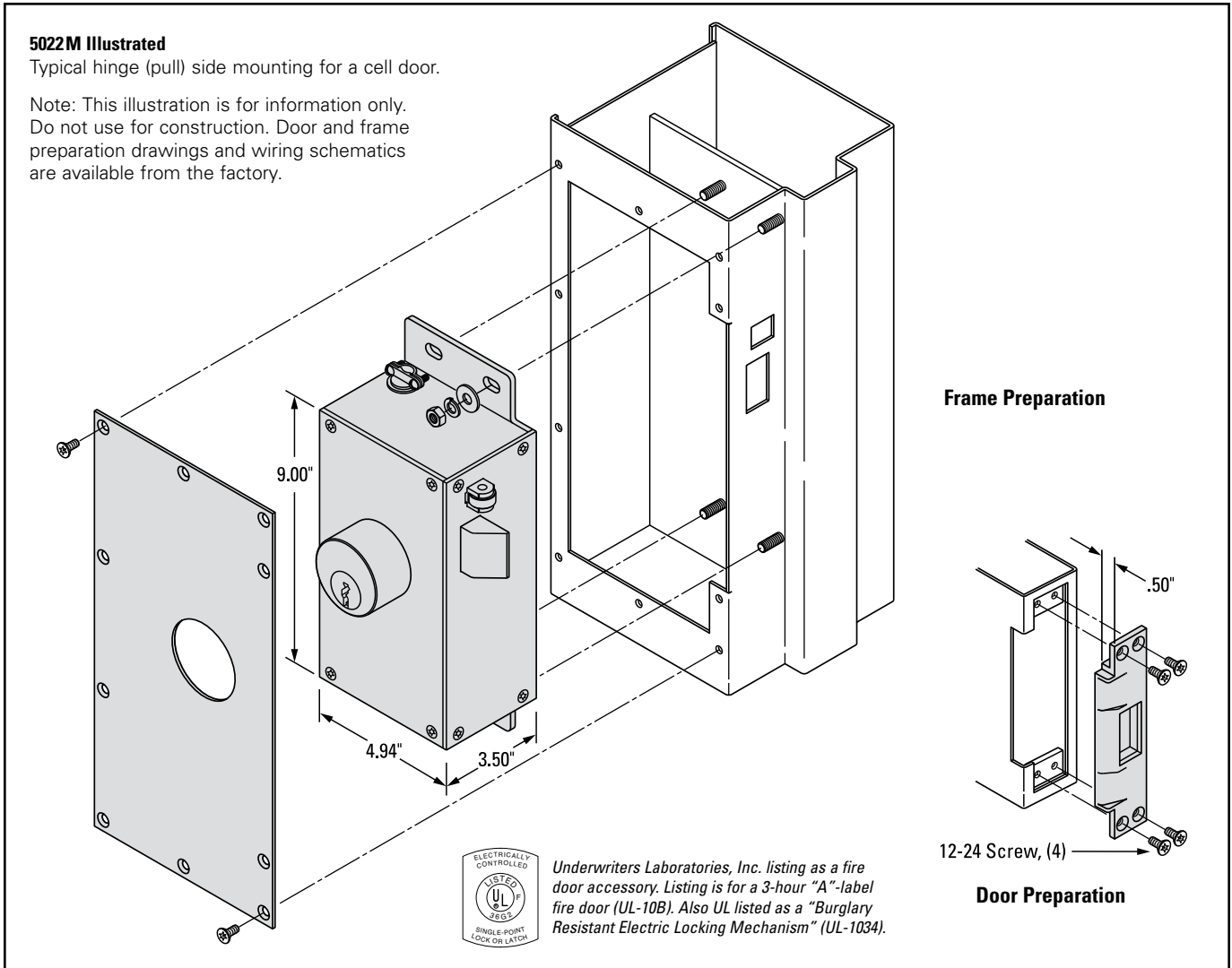

### Standard Features

- Lock case and cover made of 10 gauge steel, electroplated for corrosion resistance
- Beveled latch made of saw-resistant hardened steel with a full 1" throw and 3/4" x 1-1/2" cross section.
- Cast stainless steel strike plate.
- All internal parts are cast, fabricated or turned stainless steel.
- Maintained Switch Latch Holdback (**MSLH**) function (see "Function Guide for Motorized Locks")
- Lock status switch (**LSS**) trips when the latch is in a deadlocked condition. Used in a signal circuit to indicate lock status – unlocked or deadlocked – via control panel lights and/or alarm devices. The LSS is also used to control an electrical interlock, which permits only one of a group of doors

to be unlocked electrically at any time. *Note: For positive, tamper resistant signaling of a closed and deadlocked door, a sensitive door position (DPS) switch must be wired in combination with the LSS. Our DPS Nos. 201023 or 201030 are recommended.*

- Fitted for mechanical operation via either RRBLs proprietary "Mogul" or user's commercial key cylinder. (Factory supplied commercial key cylinder optional.) For stop side only or both side frame keying, the frame manufacturer must provide stop (push) side cylinder access or optional "key cylinder extension" (**KCE**). Key cylinder(s) must be factory assembled in lock.
- Available cylinder finish – Satin Chrome (ANSI 626, US26D)

- Plug connectors are provided for ease in wiring and removal.
- Exposed fasteners – pinned "Torx" head

### Electrical Data

- Motor – 24VDC, 1.0 amp or 120VAC, 3 amp
- Lock Status Switch – 125/250VAC, 5 amp, SPDT (Form C)

### CERTIFICATIONS

- The Model 5020M complies with all test standards (Grade 1 where applicable) set forth in ASTM F1577 – "Standard Test Methods for Detention Locks for Swinging Doors." Copies of the independent third party testing laboratory certification reports are available on request.
- Fire Rated to 3 Hour per UL10B.

# AC5020M

## Optional Features and Ordering

### Optional Features

- **FKC** – Factory supplied high security commercial key cylinder with collar. Keys are ordered separately
- **MOG** – Supplied with RRBLS Mogul proprietary 2" diameter 6-pin cylinder. UL listed locking cylinder (UL-437). Keys are ordered separately.

- **KCE** – Key Cylinder Extension

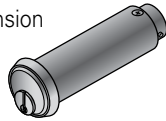

In lieu of a conventional stop (push) side key cylinder access opening in the frame, a key cylinder extension extends the working length of a commercial or Mogul key cylinder to adapt to outside jamb depths. This option applies to one side stop or both side keying only. Customer supplied cylinders must be factory fitted to each KCE. (Jamb depth dimension required with order.)

- **CKS** – Controlled Key Switch

An internal limit switch enables electrical unlocking by one-way only rotation of a change level key (factory cylinder modification required). The change key unlock circuit can be disabled at the lock control panel. Mechanical unlocking is by a master level key. This feature is used to select periods when change key unlocking is permitted, e.g. by prison inmates who carry a key to their cell.

- **MLH** – Mechanical Latch Holdback Key operation, counter to standard spring return latch rotation, enables maintained latch holdback (i.e. unlocked condition) with the key removed. **Relocking is by key only.** Optionally, keying for this feature can be unique since its rotation is opposite that for standard unlocking and, therefore, enables restricted staff usage of this function.

The MLH feature is useful in a detention facility to allow flexibility of operational policies. For example:

- 1) The MLH facilitates freedom of inmate movement from their sleeping room within a designated space (e.g. dayroom) and time period.
- 2) The MLH requires correctional officers to interact personally with inmates when performing cell key lock/unlock duties as opposed to remote control panel switching.
- 3) In addition, the MLH feature helps to prevent a commonplace open cell door lock abuse scenario whereby an inmate surreptitiously wedges the lock's auxiliary latch to a retracted position to produce a dead latched condition and then forcibly and repeatedly slams the door against the immovable latch in an attempt to inflict damage to the lock mechanism.

- **MLHRR** – Mechanical Latch Holdback with Remote Release. (Patent: US 10,947,756 B2) This feature is an enhancement to the MLH option above to enable relocking of a door(s) by either a key **or electrically** from a control panel. This ability to override the MLH feature from a remote location is applicable in a detention facility when, in an emergency situation, it is necessary to institute a quick lockdown and preclude the time consuming need to relock doors locally by key.
- **TMS** – Tamper Monitor Switch  
A limit switch that signals (e.g. via light and/or audible alarm) manipulation of the lock's auxiliary bolt (a.k.a. roller bolt) when a door is ajar. The purpose is to alert correctional officers to suspicious activity at a door (e.g. lock abuse). (Not available with the MCLH-E function.)

### Ordering Information 5020M – Motor Power Series

Model	Description
5022M	5020M keyed hinge side only
5026M	5020M keyed both sides

*Consult with our technical service personnel regarding custom applications such as retrofits to existing lock installations and special mounting situations.*

**Example: 5022 M – 24VDC – MSLH – MOG – RHR – Hinge-Side (PULL) – US26D**

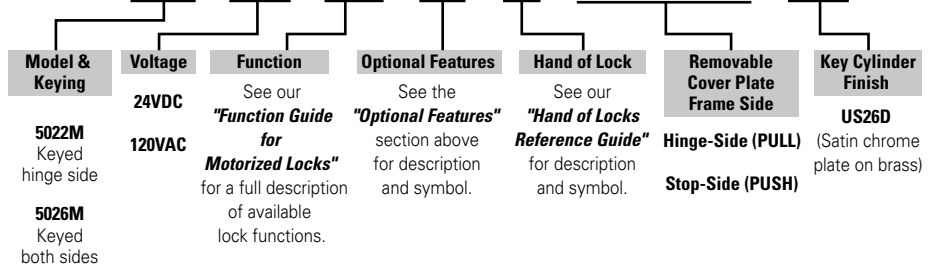

**R.R. BRINK LOCKING SYSTEMS, INC.**  
500 Earl Road • Shorewood, IL 60404  
Tel: 815-744-7000 • Fax: 815-744-7020  
www.rrbrink.com

# AC5020S

## Electromechanical Automatic Deadlocking Latch High Security and Impact Resistant – 1" Throw

120VAC Solenoid Actuated and Manual Key Unlocking – Jamb Mounted



*Hinge-Side (Pull)  
Frame Mounting*

Locate removable  
cover plate on  
non-secure side  
of frame

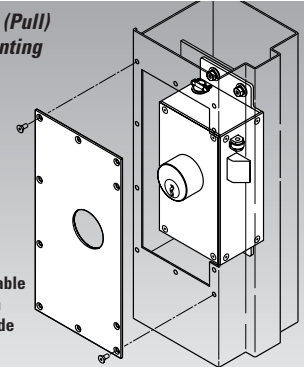

*Stop-Side (Push)  
Frame Mounting  
with KCE*

Locate removable  
cover plate on  
non-secure side  
of frame

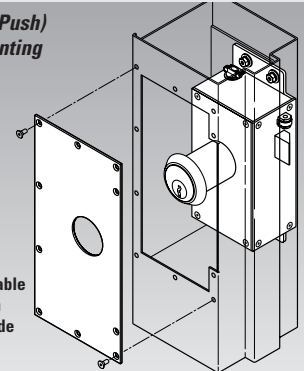

*Stop-Side (Push)  
Frame Mounting  
with Pocket*

Locate  
removable  
cover plate on  
non-secure side  
of frame

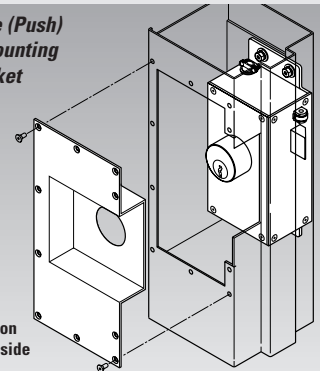

**R.R. BRINK LOCKING SYSTEMS, INC.**  
500 Earl Road • Shorewood, IL 60404  
Tel: 815-744-7000 • Fax: 815-744-7020  
www.rrink.com

### Application

- The 5020S is widely used in medium and maximum security detention facilities for remotely controlled electric unlocking of inmate room and passage doors.
- This lock is ideal as a component in attack resistant security perimeters in sensitive areas of commercial, governmental, and industrial buildings.
- Electric unlocking is accomplished by a 120VAC solenoid actuator. Latch retraction is quick and accompanied by a noticeable clap sound.
- Mechanical latch retraction by pin tumbler key cylinder—commercial or “Prison Mogul” types.
- The Model 5020S normally is jamb mounted in a steel door frame (14 gauge minimum) in a specially fabricated and reinforced lock pocket (or mortar box).
- The lock mechanism can be accessed without removal from the frame via an access plate on the non-secure side of the frame.
- Impact tested to Security Grade 1 per ASTM F1450 and F1577.
- When used in exterior locations, moisture proofing of the lock enclosure is essential and an internal resistance heating strip is recommended when the lock may be subjected to extreme freezing conditions.

# AC5020S

## Electromechanical Automatic Deadlocking Latch – 1" Throw High Security/Impact Resistant

120 VAC solenoid actuated and manual key unlocking via standard or Mogul key cylinder – jamb mounted

### Standard Features

- Lock case and cover made of 10 gauge steel, electroplated for corrosion resistance
- Beveled latch made of saw-resistant hardened steel with a full 1" throw and 3/4" x 1-1/2" cross section.
- Cast stainless steel strike plate.
- Working parts are high strength bronze or stainless steel.
- Maintained Switch Latch Holdback (**MSLH**) function (For other available functions, see catalog page "Function Guide for Motorized Locks", item 2 under "General Comments".)
- Lock status switch (**LSS**) trips when the latch is in a deadlocked condition. Used in a signal circuit to indicate lock status – unlocked or deadlocked – via control panel lights and/or alarm devices. The LSS is also used to control an electrical interlock, which permits only one of a group of doors to be unlocked electrically at any time. *Note: For positive, tamper resistant signaling of a closed and deadlocked door, a sensitive door position (DPS) switch must be wired in combination with the LSS. Our DPS Nos. 201030 or 201090 are recommended.*

- Fitted for mechanical operation via either RRBLs proprietary "Mogul" or user's commercial key cylinder. (Factory supplied commercial key cylinder optional.) For stop side only or both side frame keying, the frame manufacturer must provide stop (push) side cylinder access or optional "key cylinder extension" (**KCE**). Key cylinder(s) must be factory assembled in lock.
- Plug connectors are provided for ease in wiring and removal.
- Exposed fasteners – pinned "Torx" head
- Available cylinder finish – Chrome (ANSI 626, US26D)

### Electrical Data

- Solenoid – 120VAC – Laminate Design – Intermittent Duty – 60Hz standard – 10 ampere in-rush, 0.75 ampere seated.

NOTE: For applications utilizing 50Hz electrical input, consult factory prior to order. The life cycle of a 60Hz rated solenoid operated with 50Hz current is shortened due to possible overheating. Therefore, a non-standard 50Hz solenoid is recommended, particularly for high usage applications.

- Lock Status Switch – 125/250VAC, 5 amp, SPDT (Form C)

### 5022S Illustrated

Typical hinge (pull) side mounting for a cell door.

Note: This illustration is for information only. Do not use for construction. Door and frame preparation drawings and wiring schematics are available from the factory.

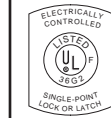

Underwriters Laboratories, Inc. listing as a fire door accessory. Listing is for a 3-hour "A"-label fire door (UL-10B). Also UL listed as a "Burglary Resistant Electric Locking Mechanism" (UL-1034).

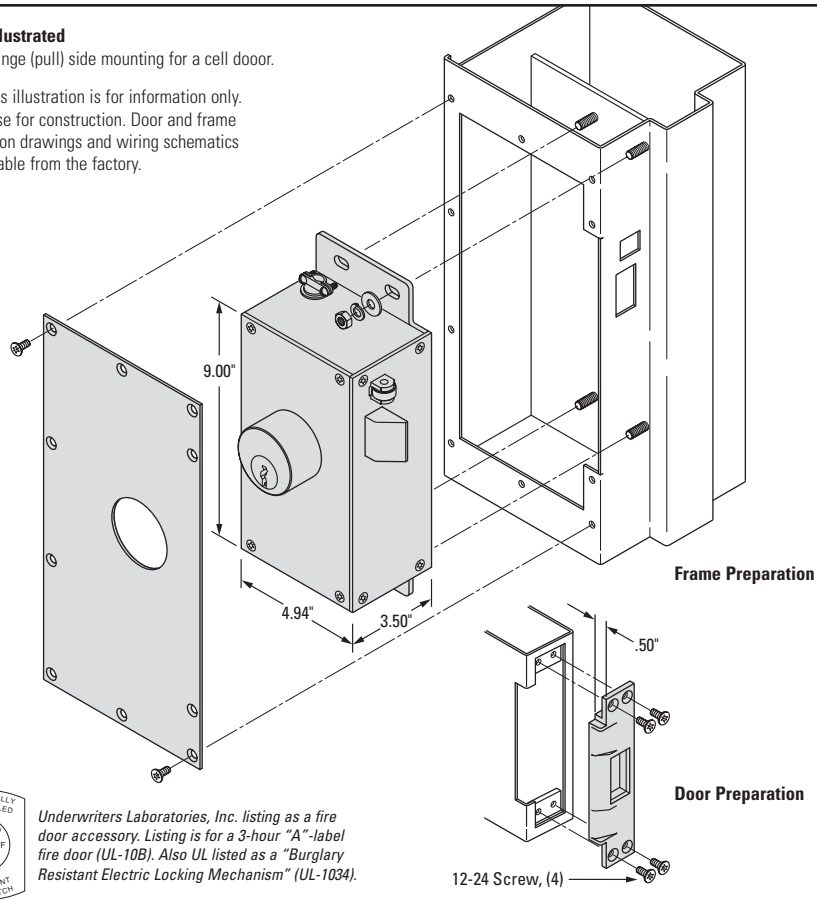

### Optional Features

- **FKC** – Factory supplied high commercial security key cylinder with collar – two change keys/cylinder
- **MOG** – Supplied with RRBLs Mogul proprietary 2" diameter 6-pin cylinder. UL listed locking cylinder (UL-437). Keys are ordered separately.
- **KCE** – In lieu of a conventional stop (push) side key cylinder access opening in the frame, a key cylinder extension extends the working length of a commercial or Mogul key cylinder to adapt to outside jamb depths. This option applies to one side stop or both side keying only. Customer supplied cylinders must be factory fitted to each KCE. (Jamb depth dimension required with order.)

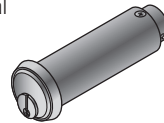

- **CKS** – Factory key cylinder modification and an internal limit switch produce a key switch feature which electrically actuates the lock by one-way only rotation of the change level key. This feature can be rendered inoperative by switch from a remote control panel. Mechanical unlocking is by a master key. This feature is indicated when it is desirable to restrict periods when key unlocking is possible, e.g. building access or prison inmates who carry a key to their cell.
- **Electrical Functions MCLH-M, MCLH-E, and MSLH/MCLH-E** – (see notes 2 and 3 on "Motor Lock Function Reference Guide" catalog sheet.)
- **TMS** (Tamper Monitor Switch) - A limit switch that signals (e.g. via light and/or audible alarm) manipulation of the lock's auxiliary bolt (a.k.a roller bolt) when a door is ajar. The purpose is to alert correctional officers to suspicious activity at a door (e.g. lock abuse). Not available with MCLH-E function.

### Ordering Information – 5020S Solenoid Actuated Series

Model	Description
5021S	5020S keyed stop side only
5022S	5020S keyed hinge side only
5026S	5020S keyed both sides

Consult with our technical service personnel regarding custom applications such as retrofits to existing lock installations and special mounting situations.



**R.R. BRINK LOCKING SYSTEMS, INC.**  
500 Earl Road • Shorewood, IL 60404  
Tel: 815-744-7000 • Fax: 815-744-7020  
www.rrbrink.com

Example: **5021 S – MSLH – KCE – LH – Stop-Side (PUSH) – US4**

Model & Keying	Function	Optional Features	Hand of Lock	Removable Cover Plate Frame Side	Key Cylinder Finish
<b>5021S</b> Keyed stop side	See our " <b>Motor Lock Function Reference Guide</b> " for a full description of available lock functions.	See the " <b>Optional Features</b> " section above for description and symbol.	See our " <b>Hand of Locks Reference Guide</b> " for description and symbol.	<b>Hinge-Side (PULL)</b>	<b>US4 or US26D</b> (standard)
<b>5022S</b> Keyed hinge side					
<b>5026S</b> Keyed both sides					

# 5520

## Electromechanical Automatic Deadlocking Latch for Sliding Doors

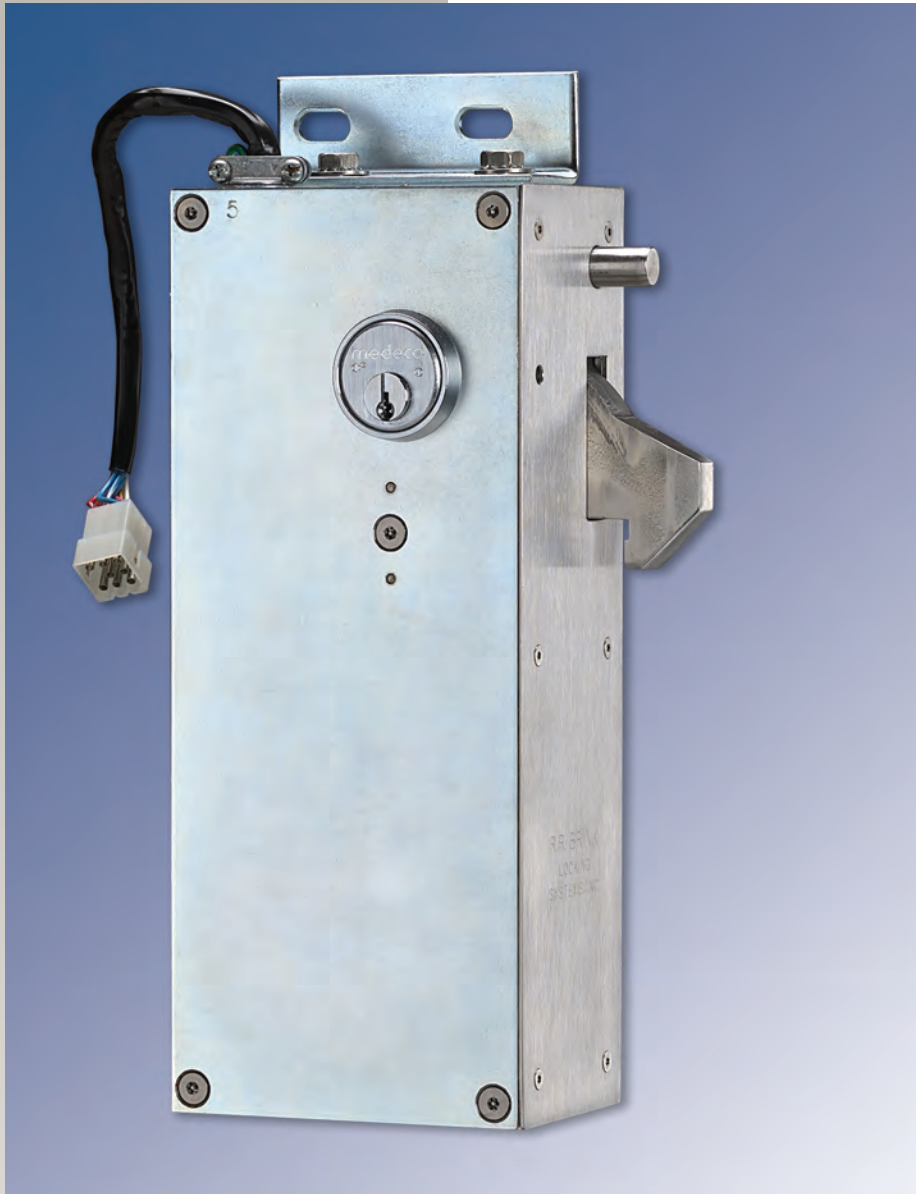

### Application

- The 5520 is a frame mounted, electrically actuated automatic deadlocking latch for unlocking sliding doors. In detention facilities, its use should be restricted to medium security housing for both new construction and for retrofitting existing inmate cells where remotely controlled unlocking is a life safety requirement. Also, the 5520 is appropriate for securing sliding doors in commercial and governmental buildings.
- The standard 5520 (designation 5520M) is actuated by a 120VAC motor (a 24VDC motor and 120VAC solenoid are optional – designations 5520-M24 and 5520S, respectively). Motor operation is quiet and produces higher torque force than the solenoid, which features fast action.
- The standard operating function for both motor and solenoid actuated models is “Momentary Contact Latch Holdback – Electrical” (MCLH-E) (For other available functions, see catalog page “Function Guide for Motorized Locks”, item 3 under “General Comments”). The MCLH-E function utilizes a momentary contact control panel switch that, when actuated, causes the 5520 to unlock electrically and remain unlocked until the door is moved ajar. It is recommended that the standard MCLH-E function be used only in locations where surreptitious deadlocking of the hook bolt by wedging of the deadlock pin to a depressed position is not a concern. Otherwise, lock damage might result by slamming a door against an immovable (i.e. deadlocked) hook bolt. Where such abuse is anticipated, the optional “Maintained Switch Latch Holdback” (MSLH) motor function is recommended. With the MSLH function, the 5520 hook bolt is actuated by a maintained contact control panel switch to the raised unlocked position where it will remain (without power if motor operated) until it is switched to the lock mode. This MSLH function precludes inflicting intentional damage to the lock mechanism by slamming the door against the hook bolt when the latter has been deadlocked via stealth.
- Manual key unlocking is by a commercial mortise key cylinder supplied by either the end-user or the factory or an RRBSL Mogul prison pin tumbler cylinder.



*The 5520 can be custom mounted in combination with our No. 57100 track, hanger, and bottom guide set to provide remotely controlled unlocking of existing sliding door installations.*



**R.R. BRINK LOCKING SYSTEMS, INC.**  
500 Earl Road • Shorewood, IL 60404  
Tel: 815-744-7000 • Fax: 815-744-7020  
www.rrbrink.com  
Email: rbrink@rrbrink.com



## Standard Features

- Mounting angles for frame attachment.
- Electric operation by motor (24VDC or 120VAC) or 120VAC solenoid.
- Lock case made of 11 gauge steel, electroplated for corrosion resistance.
- Latch of investment cast of stainless steel.
- Cast stainless steel strike plate.
- Working parts of stainless steel.
- Momentary Switch Latch Holdback - Electric (MCLH-E) or Maintained Switch Latch Holdback (MSLH) functions (see "Function Guide for Motorized Locks" catalog page).
- Lock status switch (LSS) trips when the latch is in a deadlocked condition. Used in a signal circuit to indicate lock status – unlocked or deadlocked – via control panel lights and/or alarm devices. The LSS is also used to control an electrical interlock, which permits only one of a group of doors to be unlocked electrically at any time. Note: For positive, tamper resistant signaling of a closed and deadlocked door, a sensitive door position (DPS) switch must be wired in combination with the LSS.
- Fitted for mechanical operation via either RRBLs proprietary "Mogul" or user's commercial key cylinder. (Factory supplied commercial key cylinder optional.)
- Available cylinder and faceplate finishes – Satin Brass (ANSI 606, US4) or Chrome (ANSI 626, US26D)
- Plug connectors are provided for ease of field wiring and lock removal.
- Exposed fasteners – pinned "Torx" head

## Electrical Data

- Motor – 24VDC, 1.0 amp or 120VAC, 3 amp
- Solenoid – 120VAC, 10amp inrush, 1.2 amp seated
- Lock Status Switch – 125/250VAC, 5 amp, SPDT (Form C)

## Optional Features

- FKC – Factory supplied high security commercial key cylinder with collar – two change keys/cylinder
- MOG – Supplied with RRBLs Mogul proprietary 2" diameter 6-pin cylinder. UL listed locking cylinder (UL-437). Keys are ordered separately.
- MCS – Motor control switch allows 5520 to be used in combination with a power door operator where an unlocking and door moving delay sequence is mandatory.



## R.R. BRINK LOCKING SYSTEMS, INC.

500 Earl Road • Shorewood, IL 60404  
Tel: 815-744-7000 • Fax: 815-744-7020  
www.rrbrink.com  
Email: rbrink@rrbrink.com

# 5520

## Electromechanical Automatic Deadlocking Latch for Sliding Doors

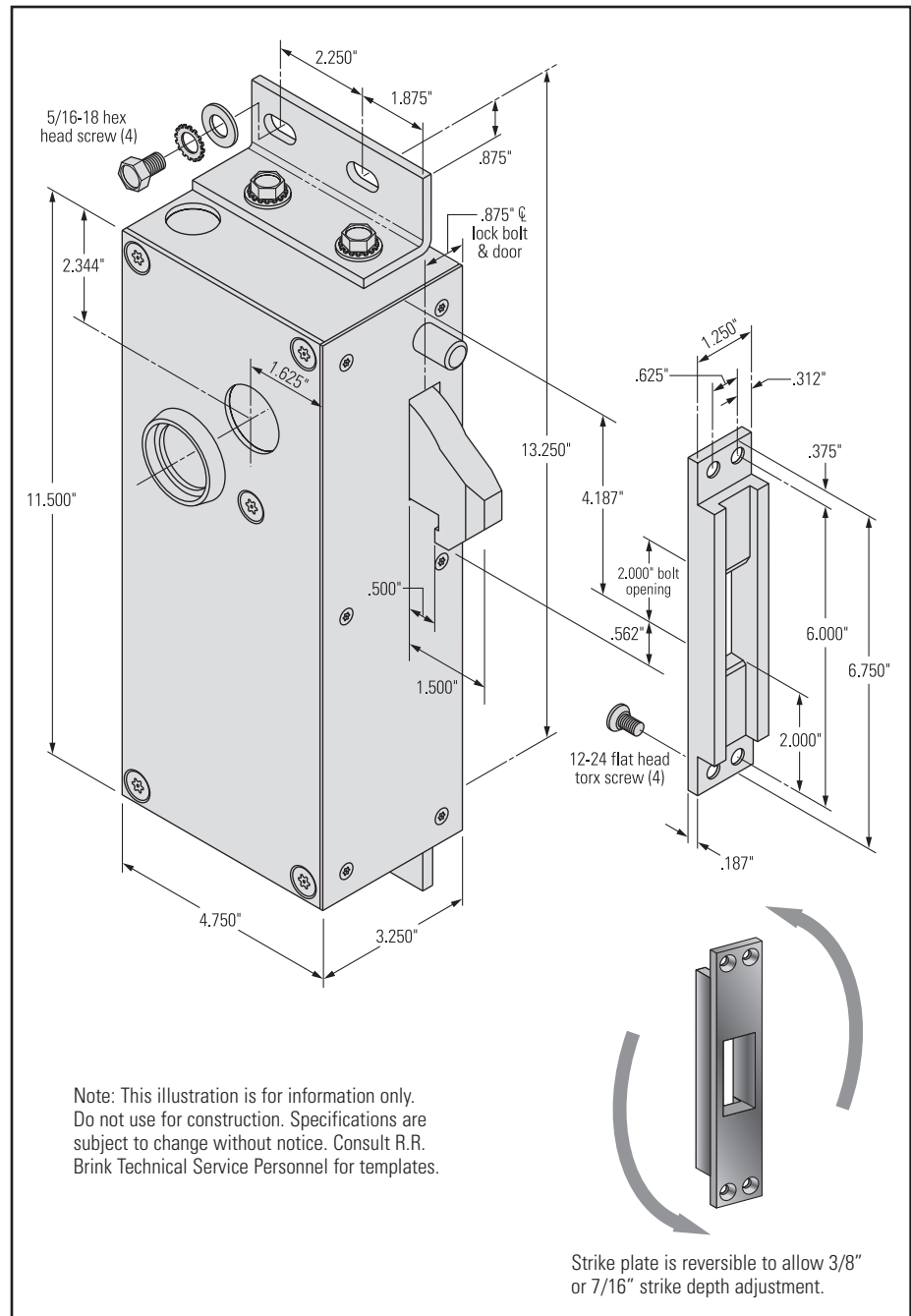

## Ordering Information – 5520 Series

Model	Description	Keying
5522M	Motor power (120VAC)	Keyed door front side only
5526M	Motor power (120VAC)	Keyed both sides
5522-M24	Motor power (24VDC)	Keyed door front side only
5526-M24	Motor power (24VDC)	Keyed both sides
5522S	Solenoid power (120VAC)	Keyed door front side only
5526S	Solenoid power (120VAC)	Keyed both sides

Consult with our technical service personnel regarding custom applications such as retrofits to existing lock installations and special mounting situations.

# 7010

## Lever-Tumbler Mechanical Deadbolt Lock for Utility Closet Access Doors and Panels



*Investment cast prison paracentric key  
(must be ordered separately)*



*Bolt Keepers (must be ordered separately)*



**Mortise  
7010K**

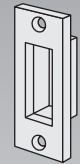

**Mortise With  
Dust Box  
7010KD**

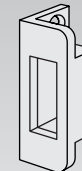

**Surface Applied  
7010SA**



**R.R. BRINK LOCKING SYSTEMS, INC.**  
500 Earl Road • Shorewood, IL 60404  
Tel: 815-744-7000 • Fax: 815-744-7020  
[www.rrbrink.com](http://www.rrbrink.com)

### Application

The 7010 is the industry standard lever tumbler deadbolt widely used in correctional facilities for maximum security locking of utility access panels.

The 7010 is recommended for key controlled locking of electrical and plumbing access panels, roof hatches, and miscellaneous small openings within the secure perimeter of a jail or prison.

The 7010 is not recommended for use on full size doors. Both locking and unlocking is accomplished with a proprietary RRBLs paracentric type key. The key cannot be removed from the lock unless the bolt is fully extended and deadlocked. This safety feature alerts the user to an obstruction in the bolt keeper or receiver which would jeopardize security.

# 7010

## Paracentric Key Mechanical Deadbolt for Utility Closet Access Doors and Panels

### Standard Features

- Industry standard template
- Investment cast steel lock case, zinc plated
- Stainless steel deadbolt
- One piece bronze paracentric cylinder
- Bolt retracted projection 1/2"
- Bolt throw: 5/8"
- Bolt size: 1-1/2" x 3/4"
- Four mounting screws included

### Accessories (must be ordered separately)

- **Prison key** – Investment cast bronze alloy – specify quantity of keys required
- **Bolt keepers**
  - 7010K standard mortise
  - 7010KD mortise with dust box
  - 7010SA surface applied

### Lock Mountings (must be ordered separately)

The access panel manufacturer usually provides a mounting plate for the 7010 lock. Otherwise RRBL's factory mountings are available for hollow metal and plate doors. They are constructed of 7-gauge steel and electroplated for corrosion resistance.

Mounting is removable for cleaning and repair of lock. Escutcheons must be purchased separately. All mounting screws are included. Consult factory directly for template of lock mountings.

- **Hollow Metal Mounting** (specify HM Mounting) – for use on hollow metal doors.
- **Plate Mounting** (specify P Mounting) – for use on steel plate doors. Allows lock to be rim mounted.

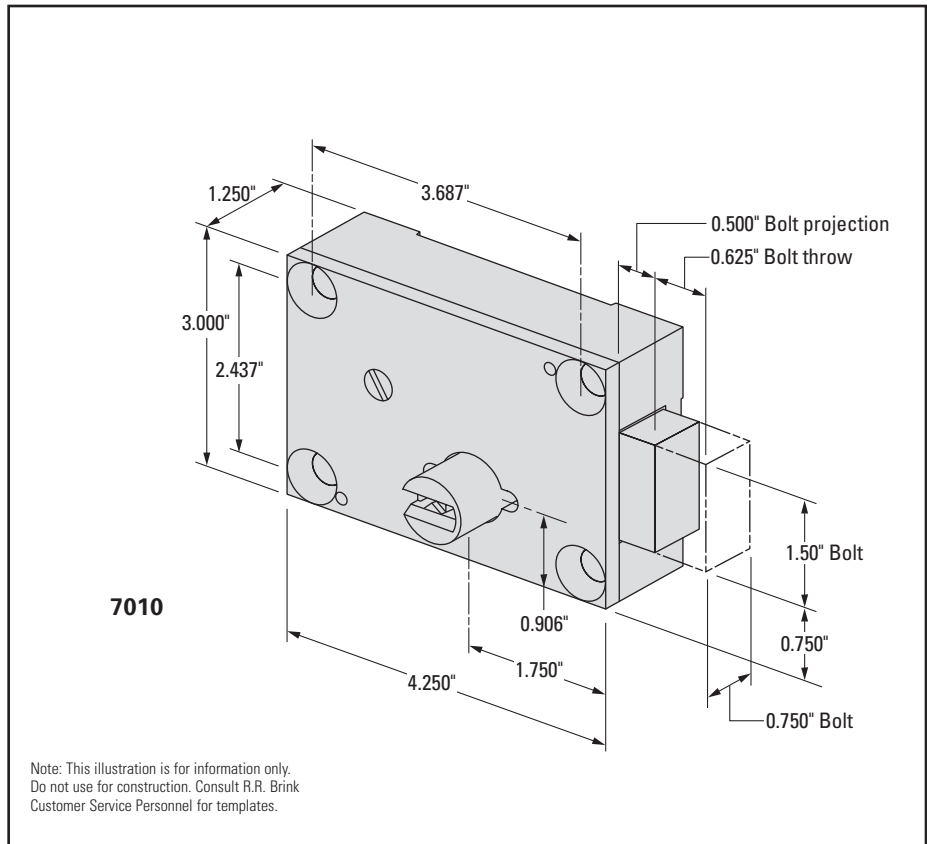

### Ordering Information

Model	Description
7012	Keyed one side
7016	Keyed both sides

### Ordering Example

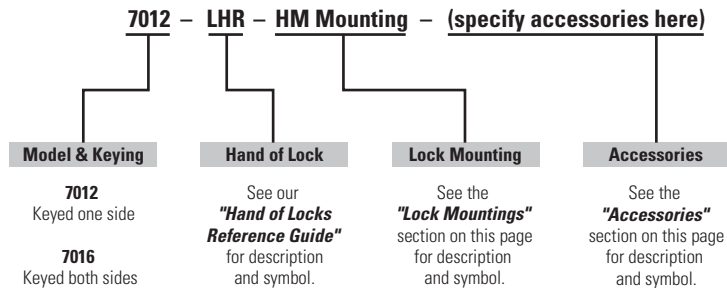

### Security Warning

With lever-tumbler locks keyed on two sides (i.e. 7016), it is important that the end user always remove the key from a locked door. If the key is left in the lock, for instance on the non-secure side to facilitate frequent unlocking, the bolt can be retracted from the opposite by turning the cylinder with a common tool. (e.g. screwdriver). This poses an unacceptable and potentially dangerous security risk!



**R.R. BRINK LOCKING SYSTEMS, INC.**

500 Earl Road • Shorewood, IL 60404  
 Tel: 815-744-7000 • Fax: 815-744-7020  
 www.rrbrink.com

# 7010 & 7010M

## Lever-Tumbler Mechanical Deadbolt Lock for Utility Closet Access Doors and Panels

7010 bolt is operated by a prison paracentric key

7010M bolt is operated by a prison mogul key



7010



7010M

**Investment cast prison paracentric key**  
(must be ordered separately)



**Investment cast RRBS mogul cylinder key**  
(must be ordered separately)



**Bolt Keepers**  
(must be ordered separately)



Mortise  
7010K



Mortise With  
Dust Box  
7010KD

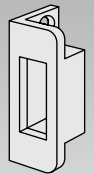

Surface Applied  
7010SA



**R.R. BRINK LOCKING SYSTEMS, INC.**  
500 Earl Road • Shorewood, IL 60404  
Tel: 815-744-7000 • Fax: 815-744-7020  
www.rrbrink.com

### Application

The 7010 and 7010M are industry standard deadbolt locks widely used for maximum security locking of utility access panels. These locks are specified for key-controlled locking of electrical and plumbing access panels, roof hatches, and miscellaneous small openings within the secure perimeter of a jail or prison such as a food pass or cuff port.

The 7010M deadbolt utilizes the same size case as the 7010, but is fitted with an RRBS prison grade key Mogul cylinder.

The 7010 and 7010M are not recommended for use on full-size doors.

Both locking and unlocking is accomplished with a proprietary RRBS investment cast prison paracentric or mogul key. The key cannot be removed from the lock unless the bolt is fully extended (i.e. deadlocked) or fully retracted. This safety feature alerts the user to an obstruction in the bolt keeper or receiver which might jeopardize security.

# 7010 & 7010M

## Paracentric and Mogul Key Mechanical Deadbolt for Utility Closet Access Doors and Panels

### Standard Features

- Industry standard template
- Investment cast steel lock case, zinc plated
- Stainless steel deadbolt
- One piece bronze paracentric cylinder (No. 7010) or Mogul cylinder (No. 7010M)
- Bolt retracted projection: 1/2" – 7010, 3/8" – 7010M
- Bolt throw: 5/8"
- Bolt size: 1-1/2" x 3/4"
- Four mounting screws included

### Accessories (must be ordered separately)

- **Prison key** – Investment cast bronze alloy – specify quantity of keys required
- **Bolt keepers**
  - 7010K standard mortise
  - 7010KD mortise with dust box
  - 7010SA surface applied

### Lock Mountings (must be ordered separately)

The access panel manufacturer usually provides a mounting plate for the 7010 lock. Otherwise RRBLs factory mountings are available for hollow metal and plate doors. They are constructed of 7-gauge steel and electroplated for corrosion resistance.

Mounting is removable for cleaning and repair of lock. Escutcheons must be purchased separately. All mounting screws are included. Consult factory directly for template of lock mountings.

- **Hollow Metal Mounting** (specify HM Mounting) – for use on hollow metal doors.
- **Plate Mounting** (specify P Mounting) – for use on steel plate doors. Allows lock to be rim mounted.

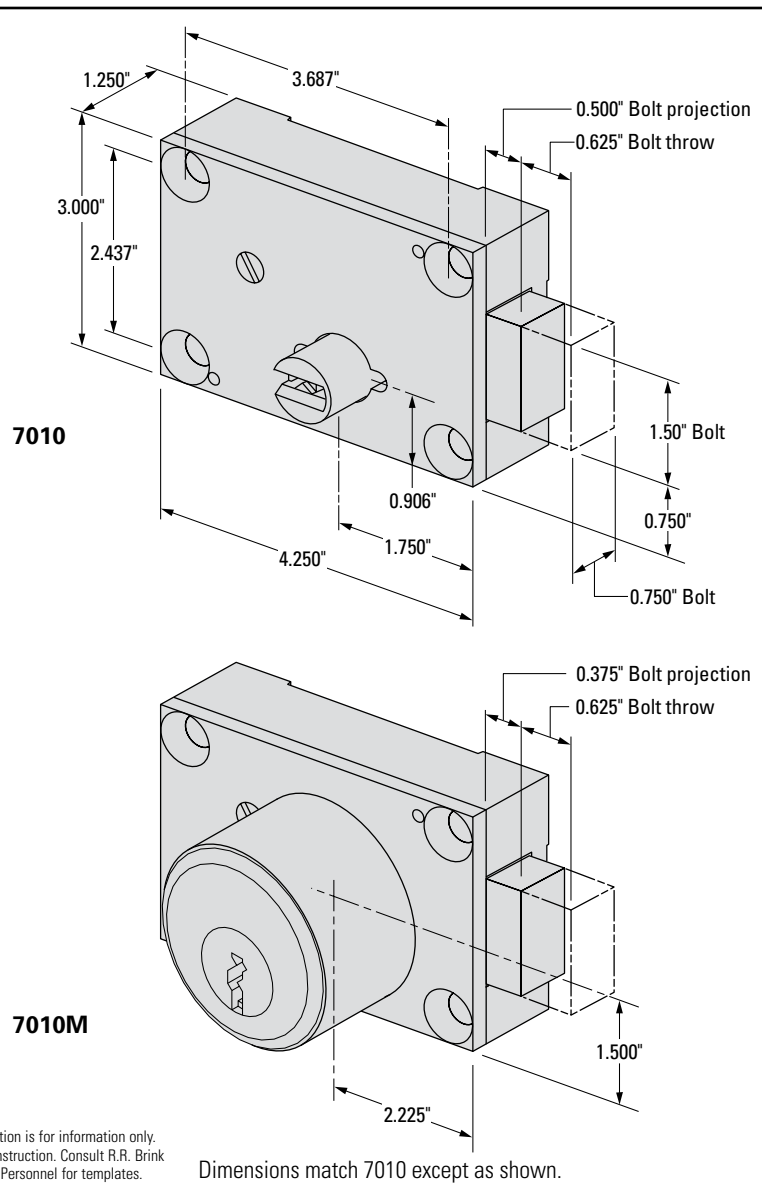

### Ordering Information

Model	Description
7012 or 7012M	keyed one side
7016 or 7016M	keyed both sides

### Ordering Example

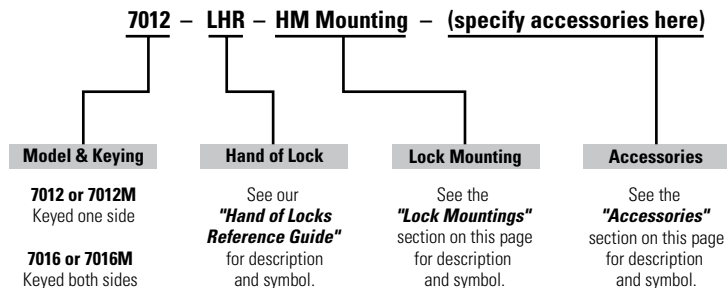

**R.R. BRINK LOCKING SYSTEMS, INC.**  
500 Earl Road • Shorewood, IL 60404  
Tel: 815-744-7000 • Fax: 815-744-7020  
www.rrbrink.com

### Security Warning

With lever-tumbler locks keyed on two sides (i.e. 7016), it is important that the end user always remove the key from a locked door. If the key is left in the lock, for instance on the non-secure side to facilitate frequent unlocking, the bolt can be retracted from the opposite by turning the cylinder with a common tool. (e.g, screwdriver). This poses an unacceptable and potentially dangerous security risk!

# 7017 & 7017M

## Latch for Food Pass and Observation Shutters

7017 latch is retracted by a prison paracentric key

7017M latch is retracted by a prison Mogul key



**7017 Lever Tumbler**



**7017M Mogul Cylinder**

*Investment cast prison paracentric key  
(must be ordered separately)*



*Investment cast RRBS Mogul cylinder  
key (must be ordered separately)*



**R.R. BRINK LOCKING SYSTEMS, INC.**

500 Earl Road • Shorewood, IL 60404  
Tel: 815-744-7000 • Fax: 815-744-7020  
www.rrbrink.com

### Application

The 7017 latch is ordinarily specified for use in any type of food pass, observation panel, wicket door, or other small swing door openings.

The lock's steel case and cover are zinc plated to provide resistance to corrosion. The 7017 has six lever tumblers with heavy springs for pick resistance.

The 7017M latch utilizes the same lock case as the 7017, but is fitted with a mogul key cylinder.

Note: Do not use the 7017 or 7017M as the primary lock for full size doors or when dead latching is a requirement.

# 7017 & 7017M

## Latch for Food Pass and Observation Shutters

### Standard Features – 7017

- Investment cast steel lock case, zinc plated
- Investment cast, bronze alloy, paracentric key cylinder.
- Stainless steel latch
- Six hard brass lever-tumblers
- Heavy bronze tumbler springs
- Random-depth key cuts impede “picking”
- Lever tumblers are provided with “anti-pick” notches for both locked and unlocked condition
- Latch retracted projection: 1/4”
- Latch throw: 1/2”
- Latch size: 1-1/2” x 3/4”
- Four mounting screws included

### Accessories (must be ordered separately)

- **Prison paracentric key** – Investment cast bronze alloy – specify quantity of keys required

### Standard Features – 7017M

- Investment cast steel lock case, zinc plated
- Stainless steel latch
- Latch retracted projection: 1/4”
- Latch throw: 1/2”
- Latch size: 1-1/2” x 3/4”
- Four mounting screws included

### Accessories (must be ordered separately)

- **Prison Mogul key** – Investment cast bronze alloy – specify quantity of keys required

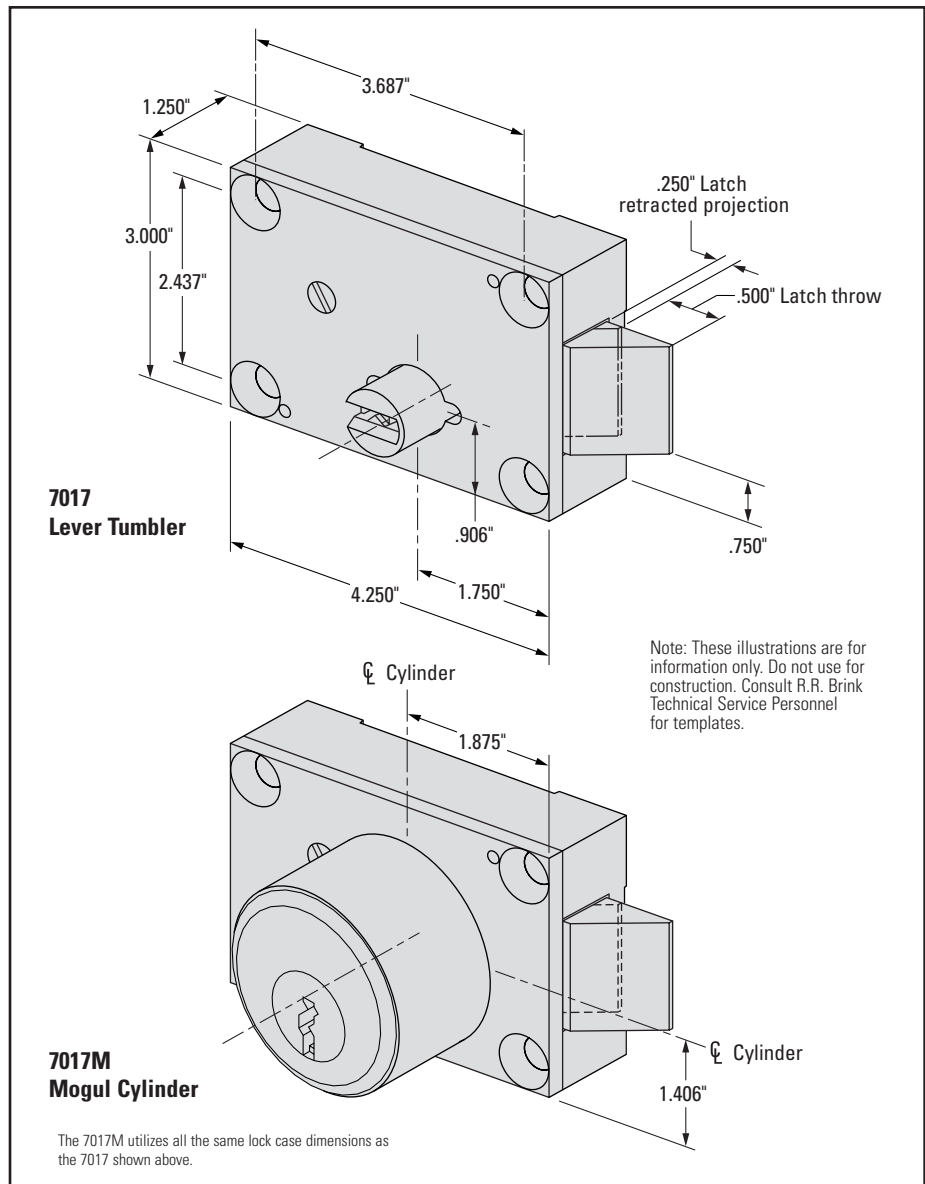

### Ordering Information

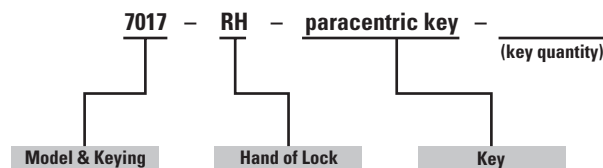

**Model & Keying**  
7017 keyed one side  
7017M keyed one side

**Hand of Lock**  
RH is the standard for all food pass applications.

**Key**  
**Prison paracentric key** – investment cast bronze alloy. (specify quantity of keys required)

**Mogul cylinder key** – (specify quantity of keys required)



### R.R. BRINK LOCKING SYSTEMS, INC.

500 Earl Road • Shorewood, IL 60404  
Tel: 815-744-7000 • Fax: 815-744-7020  
www.rrbrink.com

# 7030 & 7030D

## Six Lever-Tumbler Mechanical Locks for Sliding Doors

*7030 unlocks with a paracentric key and slam-locks with automatic deadlatch.*

*7030D unlocks and relocks with a paracentric key.*

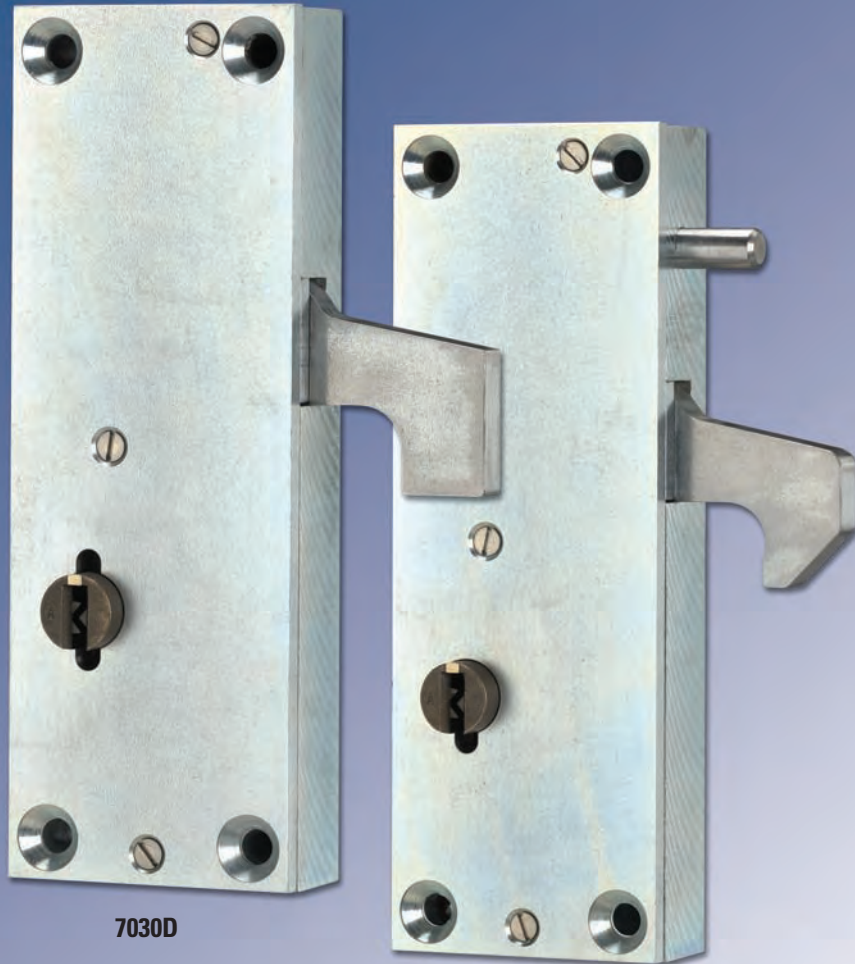

7030D

7030



**Investment cast prison paracentric key**  
*(must be ordered separately)*

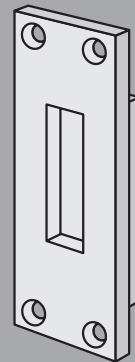

**Bolt Keeper with Dust Box (BKD)**  
*(must be ordered separately)*



### R.R. BRINK LOCKING SYSTEMS, INC.

500 Earl Road • Shorewood, IL 60404  
Tel: 815-744-7000 • Fax: 815-744-7020  
www.rrbrink.com

### Application

The 7030D is a lever tumbler deadbolt for sliding doors affording maximum security locking. In a detention facility, the 7030D is recommended for key locking and unlocking of sliding doors within the secure perimeter, e.g. cells, dayroom, and corridor sallyports. Both locking and unlocking are accomplished with a proprietary RRBS paracentric type key. Key rotation of 180° moves the hook bolt from the locked to unlocked position and vice versa. The 7030D does not slam lock. When locking, the key cannot be removed if an obstruction in the bolt keeper prevents the hook bolt from fully dropping into the horizontal deadlocked position. This safety feature alerts the user to an obstruction in the bolt keeper or receiver which would jeopardize security.

The 7030 has the same construction and dimensions as the 7030D except that it incorporates an automatic deadlocking feature actuated upon closing of the door

by depression of an auxiliary pin. It is used when the convenience of slam closing and automatic (i.e. keyless) deadlocking is of high priority. However, application of the 7030 should be limited to correctional facility locations where inmates should not have unaccompanied access such as high usage corridor and support room doors (e.g. control, kitchen, laundry, visitation areas). The 7030 should not be used to secure doors in inmate living areas, especially cells. The reason being is that the 7030 does not require manual deadlocking by key as does the 7030D deadbolt. The automatic deadlocking feature can engender a false sense of security among correctional officers that can be taken advantage of by an inmate surreptitiously obstructing the lock bolt keeper to block full engagement of the hook bolt in the keeper. When this occurs, the automatic deadlocking function is foiled and the hook bolt can be lifted to effect a breach of security.



# 7030 & 7030D

## Lever-Tumbler Mechanical Lock for Sliding Doors

### Standard Features

- Industry standard template
- Cast ductile iron lock case, zinc plated
- Investment cast, bronze alloy, one piece key cylinder
- Zinc plated, case hardened hook bolt
- Six hard brass lever-tumblers
- Heavy bronze tumbler spring
- Random-depth key cuts impede "picking"
- Lever tumblers are provided with "anti-pick" notches for both locked and unlocked condition
- Four mounting screws included

### Accessories (must be ordered separately)

- **Prison paracentric key** – Investment cast bronze alloy – specify number of keys required
- **Bolt keeper**  
BKD mortise with dust box
- **Escutcheon** – U.S. 32D or U.S. 4 finish.
- **Cylinder shield** – A surface applied flap which closes off the keyway to outside debris at exterior locations – U.S. 32D finish only.

### Lock Mountings (must be ordered separately)

The 7030 lever-tumbler lock should be mounted, enclosed, and protected with an appropriate steel mounting. Mountings are constructed of 7-gauge steel with a galvanized finish for superior corrosion-resistance. Mountings are removable for cleaning and repair of lock. Escutcheons must be purchased separately. All mounting screws are included. Consult factory directly for template of lock mountings.

- **Hollow Metal Mounting** (specify HM Mounting) – for use on hollow metal doors.
- **Plate Mounting** (specify P Mounting) – for use on steel plate doors. Allows lock to be rim-mounted.
- **Grille Mounting** (specify G Mounting) – for use on grille (steel bar) type doors. Designed for welding to grille.

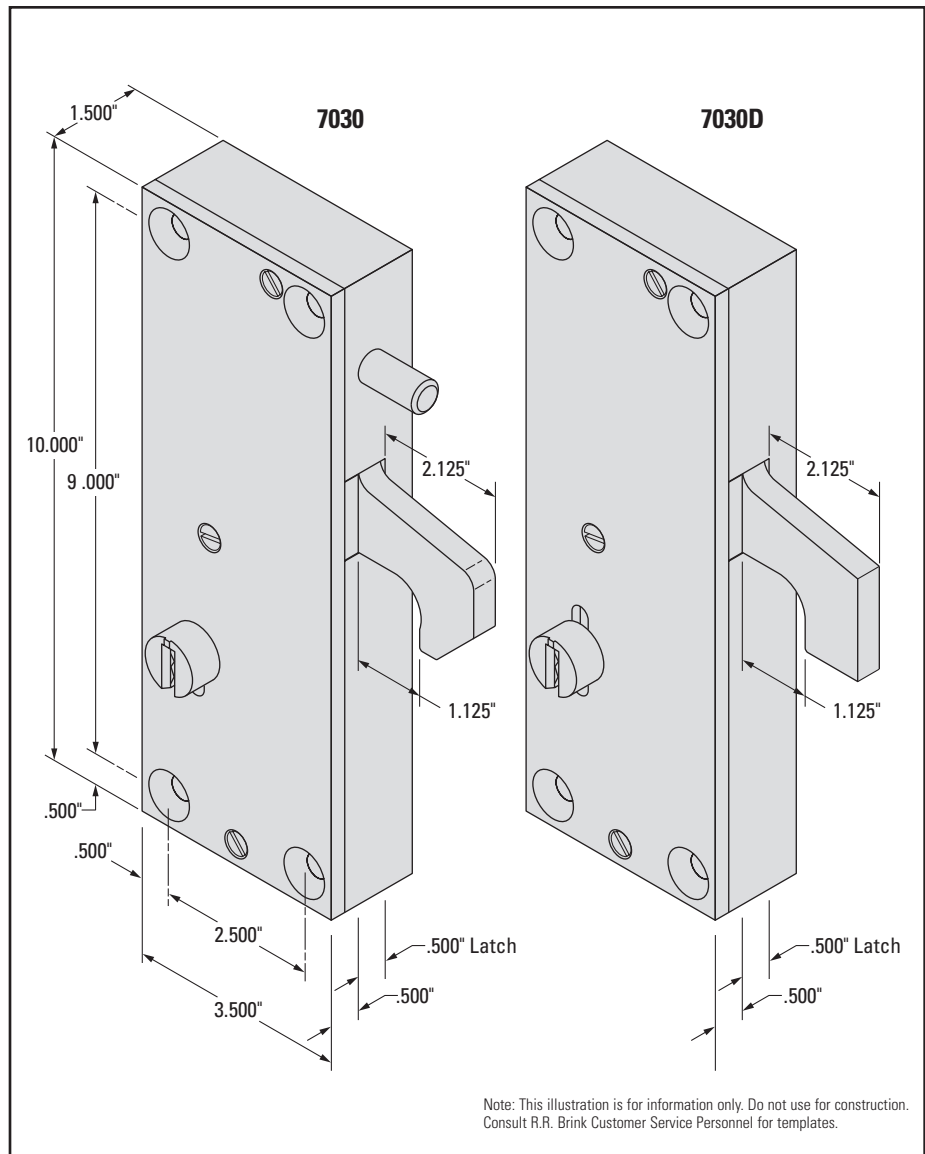

Note: This illustration is for information only. Do not use for construction. Consult R.R. Brink Customer Service Personnel for templates.

### Ordering Information

Model	Description
7032	Keyed one side
7036	Keyed two sides
7032D	Keyed one side
7036D	Keyed two sides

### Security Warning

With lever-tumbler locks keyed on two sides, it is important that the end user always remove the key from a locked door. If the key is left in the lock, for instance on the non-secure side to facilitate frequent unlocking, the bolt can be retracted from the opposite side by turning the cylinder with a common tool. (e.g. screwdriver). This poses an unacceptable and potentially dangerous security risk!

### Ordering Example

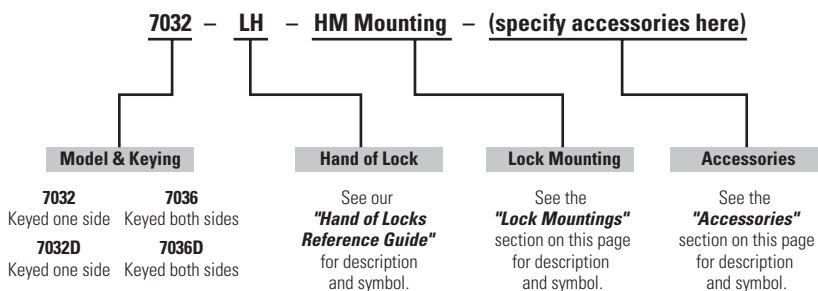

**R.R. BRINK LOCKING SYSTEMS, INC.**

500 Earl Road • Shorewood, IL 60404

Tel: 815-744-7000 • Fax: 815-744-7020

www.rrbrink.com

# 7050M

## Maximum Security, Heavy Duty Electromechanical Deadlocking Latch For Swinging Doors

24 VDC or 120 VAC Motor Power and Paracentric Key Unlocking – Jamb Mounted



Steel strike plate is zinc-plated.

Paracentric lever-tumbler key

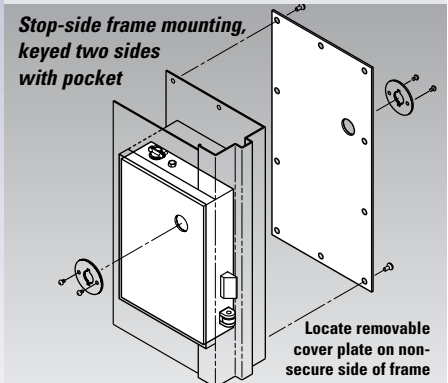
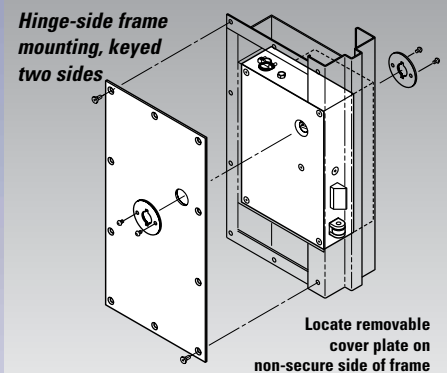
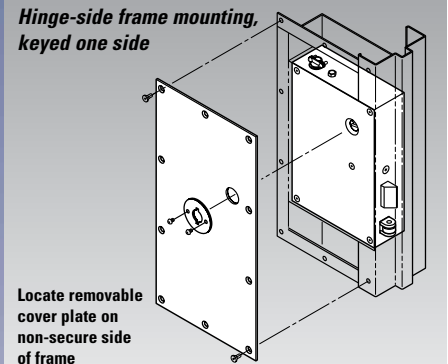

**R.R. BRINK LOCKING SYSTEMS, INC.**  
500 Earl Road • Shorewood, IL 60404  
Tel: 815-744-7000 • Fax: 815-744-7020  
www.rrbrink.com

### Application

- The 7050M motorized lock is an extra heavy weight electromechanical lock for use in openings subject to high traffic and/or where maximum attack resistance is a priority requirement. It is designed for jamb mounting in a grille or hollow metal frame (14 gauge minimum) with a custom fabricated and reinforced lock pocket (a.k.a. mortar box).
- The 7050M is recommended for remote control of maximum security locations in jails or prisons (e.g. cells, dayroom entries, and sally ports) or in other building types where openings in security perimeters must be equipped to withstand forced attack and/or constant usage.

- Electrical retraction of the latchbolt is by either a 24VDC or 120VAC gearmotor. Motor actuation is indicated where superior latch retraction force and quiet operation are important to the application.
- Mechanical latch retraction is by is by RRBS paracentric key operation of an enclosed lever tumbler lock.
- With a hollow metal frame, the lock mechanism can be serviced with the lock in the frame by removing an access plate supplied by the frame manufacturer (see illustrations above).
- When used in exterior locations, moisture proofing of the lock enclosure is essential and an internal resistance-heating strip is recommended when the lock may be subjected to extreme freezing conditions.

# 7050M

## Maximum Security, Heavy Duty Electromechanical Deadlocking Latch For Swinging Doors

24 VDC or 120 VAC motor power and Paracentric key unlocking – jamb mounted

### Standard Features

- Key unlocking at all times with an integral R.R. Brink lever-tumbler lock.
- Lock case and cover made of 7 gauge steel, electroplated for corrosion resistance
- Working parts are copper alloy or stainless steel.
- Powerful and quiet 120VAC or 24VDC motor.
- A case hardened, zinc-plated steel latch (highly resistant to wear and sawing) with a full 3/4"-inch throw. 3/4" x 2" cross section at the locking shear point.
- Electroplated steel roller bolt deadlocks latch.
- Maintained Switch Latch Holdback (**MSLH**) function (see "Lock Function Reference Guide")
- Lock status switch (**LSS**) trips when the latch is in a deadlocked condition. Used in a signal circuit to indicate lock status – unlocked or deadlocked – via control panel lights and/or alarm devices. The LSS is also used to control an electrical interlock, which permits only one of a group of doors to be unlocked electrically at any time. *Note: For positive, tamper resistant signaling of a closed and deadlocked door, a sensitive door position (DPS) switch must be wired in combination with the LSS. Our DPS Nos. 201030 or 201090 are recommended.*
- Plug connectors are provided for ease in wiring and removal.
- Exposed fasteners – pinned "Torx" head

### Electrical Data

- Motor – 24VDC, 1.0 amp or 120VAC, 3 amp
- Lock status switch – SPDT type, UL listed, 125/250 VAC, 5 amp.

### 7052M Illustrated

Hinge-side mounting. Keyed one side

Note: This illustration is for information only. Do not use for construction. Door and frame preparation drawings and wiring schematics are available from the factory.

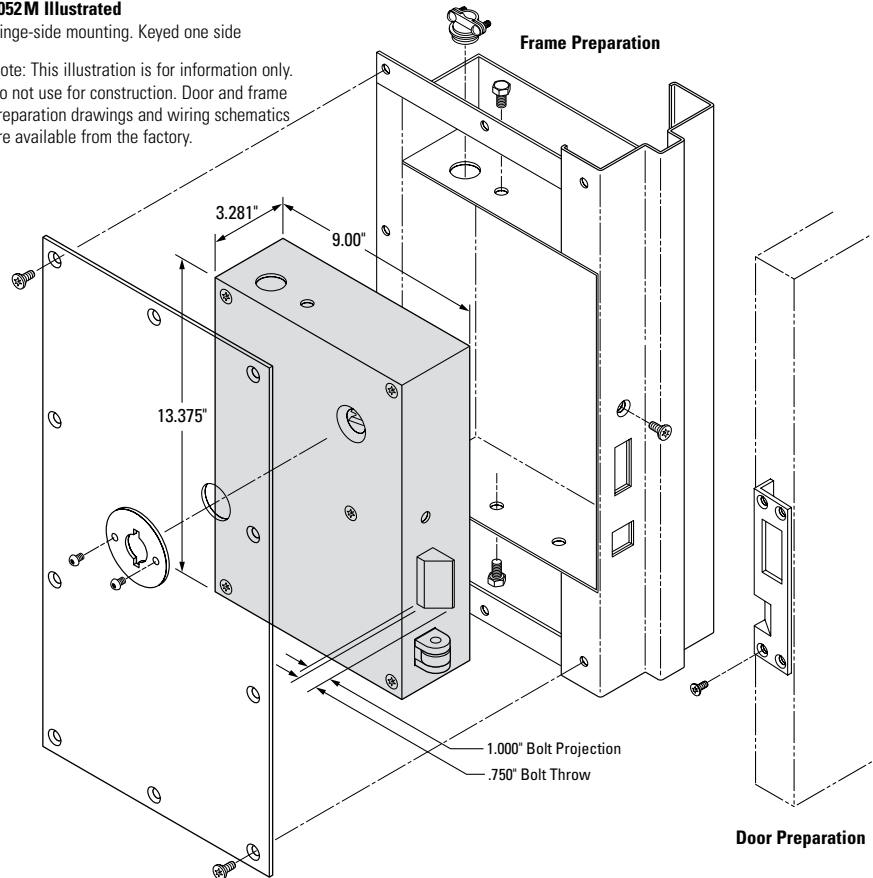

Certified by a nationally recognized independent testing laboratory to meet ASTM F1577-6.2- Impact Test Grade 1



Underwriters Laboratories, Inc. listing as a fire door accessory. Listing is for a 3-hour fire door (UL-10B). Also UL listed as a "Burglary Resistant Electric Locking Mechanism" (UL-1034).

### Security Warning

With lever-tumbler locks keyed on two sides (e.g. 7056M), it is important that the end user always remove the key from a locked door. If the key is left in the lock, for instance on the non-secure side to facilitate frequent unlocking, the bolt can be retracted from the opposite side by simply turning the cylinder with a common tool. (e.g. screwdriver). This poses an unacceptable and potentially dangerous security risk!

### Optional Accessories

- **Prison paracentric key** – order separately, not included with lock
- **Custom bolt projection** – consult factory
- **Escutcheon** – finish U.S. 32D or U.S. 4
- **Cylinder Shield** – finish U.S. 32D

### Custom Applications

Consult with our technical service personnel regarding custom applications such as retrofits to existing lock installations, special mounting situations and operational requirements.

### Ordering Information

#### 7050M – Motor Power Series

Model	Description
7052M	7050M keyed one side
7056M	7050M keyed both sides



**R.R. BRINK LOCKING SYSTEMS, INC.**

500 Earl Road • Shorewood, IL 60404

Tel: 815-744-7000 • Fax: 815-744-7020

www.rrbrink.com

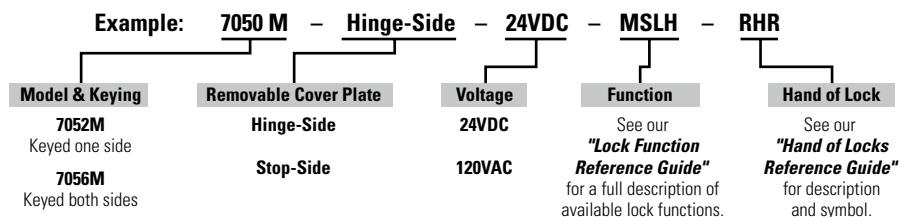

# 7050MM

## Maximum Security, Heavy Duty Electromechanical Deadlocking Latch For Swinging Doors

24 VDC or 120 VAC Motor Power – RRBLS Mogul Key Cylinder – Jamb Mounted



Steel strike plate is zinc-plated.



Mogul Key

Secure Side

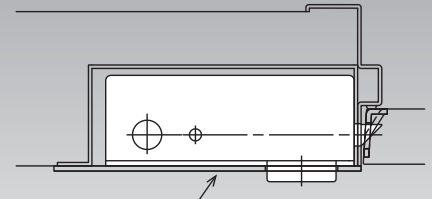

Removable Cover Plate (by others)

7052MM

Secure Side

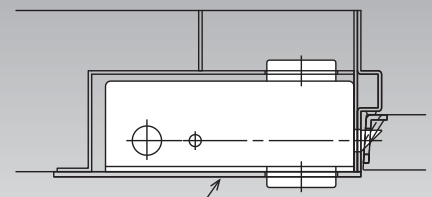

Removable Cover Plate (by others)

7056MM

Removable Cover Plate (by others)

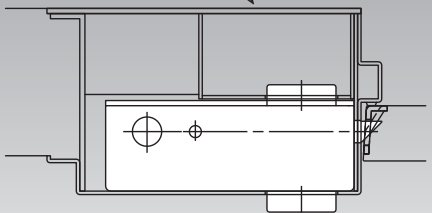

Secure Side

7056MM



**R.R. BRINK LOCKING SYSTEMS, INC.**  
500 Earl Road • Shorewood, IL 60404  
Tel: 815-744-7000 • Fax: 815-744-7020  
www.rrbrink.com

### Application

- The 7050MM motorized lock is an extra heavy weight electromechanical lock for use in openings subject to high traffic and/or where maximum attack resistance is a priority requirement. It is designed for jamb mounting in a grille or hollow metal frame (14 gauge minimum) with a custom fabricated and reinforced lock pocket (a.k.a. mortar box).
- The 7050MM is recommended for remote control of maximum security locations in jails or prisons (e.g. cells, dayroom entries, and sally ports) or in other building types where openings in security perimeters must be equipped to withstand forced attack and/or constant usage.

- Electrical retraction of the latchbolt is by either a 24VDC or 120VAC gearmotor. Motor actuation is indicated where superior latch retraction force and quiet operation are important to the application.
- Mechanical latch retraction is by pin tumbler RRBLS Mogul key cylinder.
- With a hollow metal frame, the lock mechanism can be serviced with the lock in the frame by removing an access plate supplied by the frame manufacturer (see illustrations above).
- When used in exterior locations, moisture proofing of the lock enclosure is essential and an internal resistance-heating strip is recommended when the lock may be subjected to extreme freezing conditions.

# 7050MM

## Maximum Security, Heavy Duty Electromechanical Deadlocking Latch For Swinging Doors

24 VDC or 120 VAC Motor Power – RRBL5 Mogul Key Cylinder – Jamb Mounted

### Standard Features

- Key unlocking at all times with an RRBL5 Mogul key cylinder.
- Lock case and cover made of 7 gauge steel, electroplated for corrosion resistance
- Working parts are copper alloy or stainless steel.
- Powerful and quiet 120VAC or 24VDC motor.
- A case hardened, zinc-plated steel latch (highly resistant to wear and sawing) with a full 3/4" -inch throw. 3/4" x 2" cross section at the locking shear point.
- Electroplated steel roller bolt deadlocks latch.
- Maintained Switch Latch Holdback (**MSLH**) function (see "Lock Function Reference Guide")
- Lock status switch (**LSS**) trips when the latch is in a deadlocked condition. Used in a signal circuit to indicate lock status – unlocked or deadlocked – via control panel lights and/or alarm devices. The LSS is also used to control an electrical interlock, which permits only one of a group of doors to be unlocked electrically at any time. *Note: For positive, tamper resistant signaling of a closed and deadlocked door, a sensitive door position (DPS) switch must be wired in combination with the LSS. Our DPS Nos. 201030 or 201090 are recommended.*
- Plug connectors are provided for ease in wiring and removal.
- Exposed fasteners – pinned "Torx" head

### Electrical Data

- Motor – 24VDC, 1.0 amp or 120VAC, 3 amp
- Lock status switch – SPDT type, UL listed, 125/250 VAC, 5 amp.

**7052MM Illustrated**  
Hinge-side mounting. Keyed one side

Note: This illustration is for information only. Do not use for construction. Door and frame preparation drawings and wiring schematics are available from the factory.

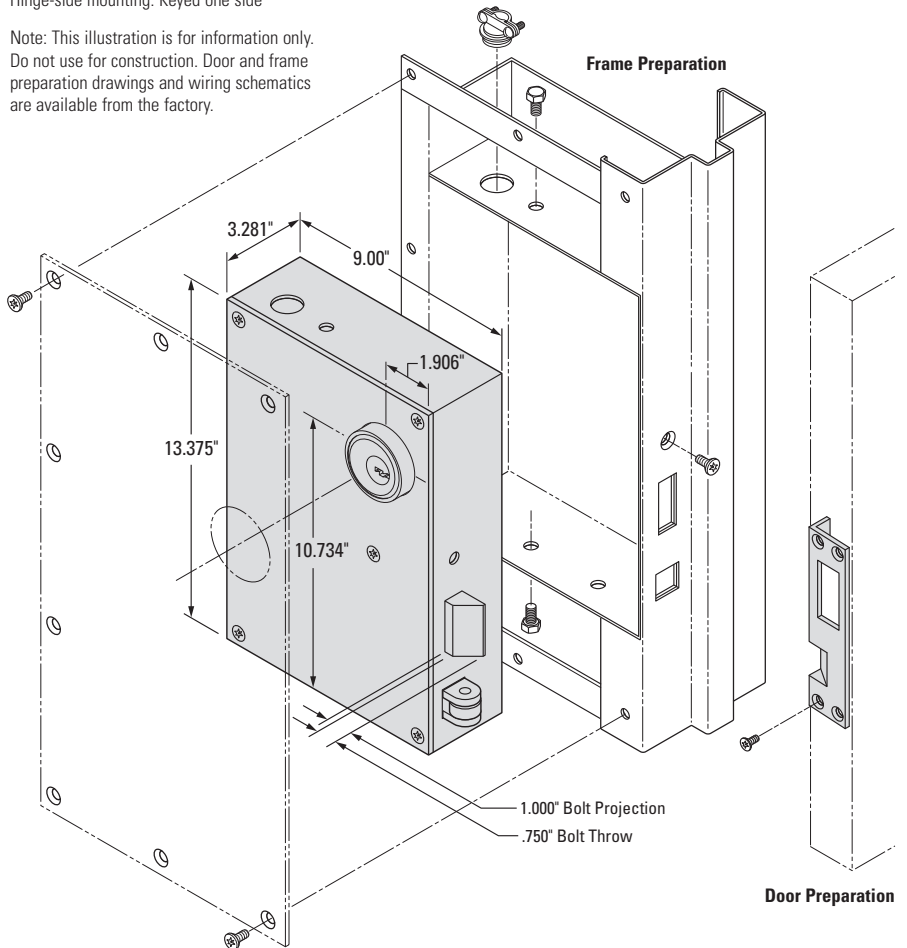

Underwriters Laboratories, Inc. listing as a fire door accessory. Listing is for a 3-hour fire door (UL-10B). Also UL listed as a "Burglary Resistant Electric Locking Mechanism" (UL-1034).

Certified by a nationally recognized independent testing laboratory to meet ASTM F1577-6.2- Impact Test Grade 1

### Custom Applications

Consult with our technical service personnel regarding custom applications such as retrofits to existing lock installations, special mounting situations and operational requirements.

### Optional Accessories

- Custom bolt projection – consult factory

### Ordering Information

#### 7050MM – Motor Power Series

Model	Description
7052MM	7050MM keyed one side
7056MM	7050MM keyed both sides



**R.R. BRINK LOCKING SYSTEMS, INC.**  
500 Earl Road • Shorewood, IL 60404  
Tel: 815-744-7000 • Fax: 815-744-7020  
www.rrbrink.com

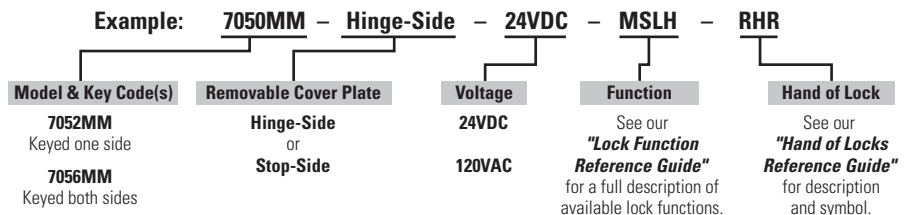

# 7050S

## Maximum Security, Heavy Duty Electromechanical Deadlocking Latch For Swinging Doors

120 VAC Solenoid Actuated and Paracentric Key Unlocking – Jamb Mounted



Steel strike plate is zinc-plated.

Paracentric lever-tumbler key

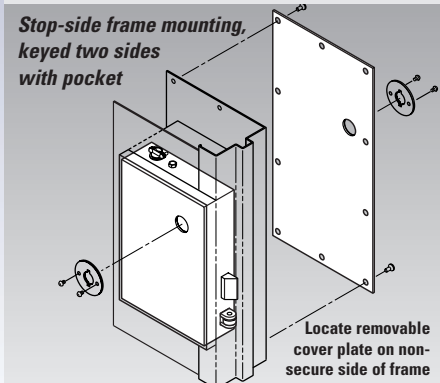
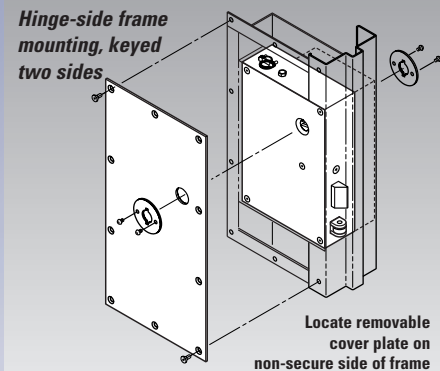
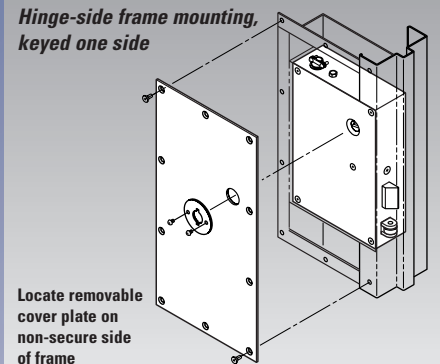

**R.R. BRINK LOCKING SYSTEMS, INC.**  
500 Earl Road • Shorewood, IL 60404  
Tel: 815-744-7000 • Fax: 815-744-7020  
www.rrbrink.com

### Application

- The 7050S solenoid actuated lock is an extra heavy weight electromechanical lock for use in openings subject to high traffic and/or where maximum attack resistance is a priority requirement. It is designed for jamb mounting in a grille or hollow metal frame (14 gauge minimum) with a custom fabricated and reinforced lock pocket (a.k.a. mortar box).
- The 7050S is recommended for remote control of maximum security locations in jails or prisons (e.g. cells, dayroom entries, and sally ports) or in other building types where openings in security perimeters must be equipped to withstand forced attack and/or constant usage.

- Electric unlocking is accomplished by a 120 VAC solenoid actuator. Latch retraction is snappy and accompanied by a noticeable clap sound.
- Mechanical latch retraction by RRBL5 paracentric key/lever tumbler lock.
- With a hollow metal frame, the lock mechanism can be serviced with the lock in the frame by removing an access plate supplied by the frame manufacturer (see illustrations above).
- Impact tested to Security Grade 1 per ASTM F1450 and F1577.
- When used in exterior locations, moisture proofing of the lock enclosure is essential and an internal resistance-heating strip is recommended when the lock may be subjected to freezing conditions.

# 7050S

## Maximum Security, Heavy Duty Electromechanical Deadlocking Latch For Swinging Doors

120 VAC solenoid actuated and Paracentric key unlocking – jamb mounted

### Standard Features

- Key unlocking at all times with an integral R.R. Brink lever-tumbler lock.
- Lock case and cover made of 7 gauge steel, electroplated for corrosion resistance
- Working parts are of high strength bronze or stainless steel.
- A case hardened, zinc-plated steel latch (highly resistant to wear and sawing) with a full 3/4"-inch throw. 3/4" x 2" cross section at the locking shear point.
- Electroplated steel roller bolt deadlocks latch.
- Maintained Switch Latch Holdback (**MSLH**) function (For other available functions, see catalog page "Function Guide for Motorized Locks", item 2 under "General Comments".)
- Lock status switch (**LSS**) trips when the latch is in a deadlocked condition. Used in a signal circuit to indicate lock status – unlocked or deadlocked – via control panel lights and/or alarm devices. The LSS is also used to control an electrical interlock, which permits only one of a group of doors to be unlocked electrically at any time. *Note: For positive, tamper resistant signaling of a closed and deadlocked door, a sensitive door position (DPS) switch must be wired in combination with the LSS. Our DPS Nos. 201030 or 201090 are recommended.*
- Plug connectors are provided for ease in wiring and removal.
- Exposed fasteners – pinned "Torx" head

### Electrical Data

- Solenoid – 120VAC – Laminate Design – Intermittent Duty – 60Hz standard – 10 ampere in-rush, 0.75 ampere seated.

NOTE: For applications utilizing 50Hz electrical input, consult factory prior to order. The life cycle of a 60Hz rated solenoid operated with 50Hz current is shortened due to possible overheating. Therefore, a non-standard 50Hz solenoid is recommended, particularly for high usage applications.

- Lock Status Switch – 125/250VAC, 5 amp, SPDT (Form C)

### 7052S Illustrated

Hinge-side mounting. Keyed one side

Note: This illustration is for information only. Do not use for construction. Door and frame preparation drawings and wiring schematics are available from the factory.

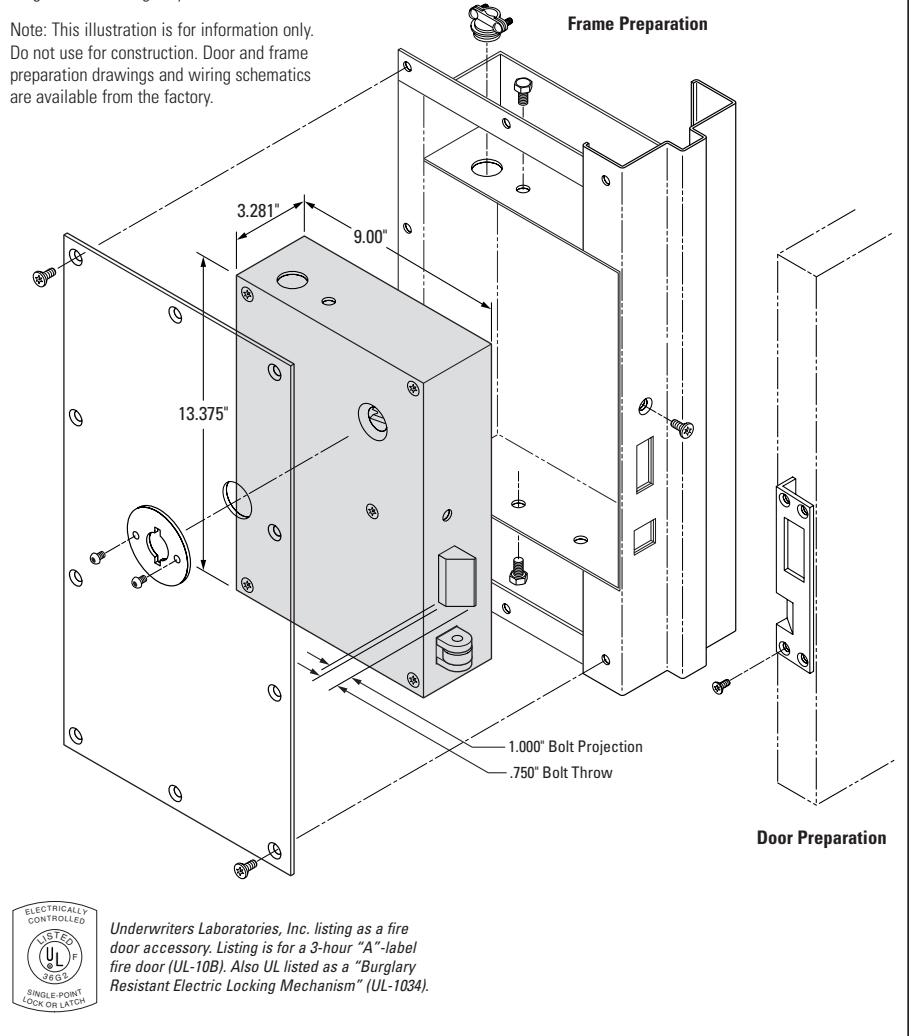

Underwriters Laboratories, Inc. listing as a fire door accessory. Listing is for a 3-hour "A"-label fire door (UL-10B). Also UL listed as a "Burglary Resistant Electric Locking Mechanism" (UL-1034).

### Optional Accessories

- **Prison paracentric key** – order separately, not included with lock
- **Custom bolt projection** – consult factory
- **Escutcheon** – finish U.S. 32D
- **Cylinder Shield** – finish U.S. 32D

### Custom Applications

Consult with our technical service personnel regarding custom applications such as retrofits to existing lock installations, special mounting situations and operational requirements.

### Ordering Information

#### 7050S – Solenoid Actuated Series

Model	Description
7052S	7050S keyed one side
7056S	7050S keyed both sides

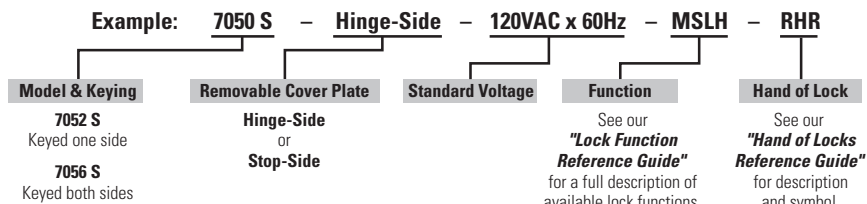

### R.R. BRINK LOCKING SYSTEMS, INC.

500 Earl Road • Shorewood, IL 60404  
Tel: 815-744-7000 • Fax: 815-744-7020  
www.rrbrink.com

# 7050SM

## Maximum Security, Heavy Duty Electromechanical Deadlocking Latch For Swinging Doors

120 VAC Solenoid Actuated – RRBLS Mogul Key Cylinder – Jamb Mounted



Steel strike plate is zinc-plated.

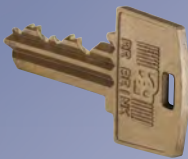

Mogul Key

Secure Side

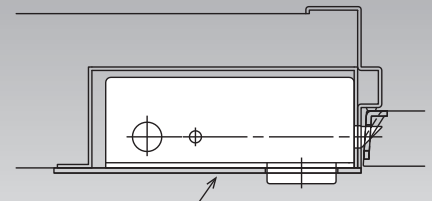

Removable Cover Plate (by others)

7052SM

Secure Side

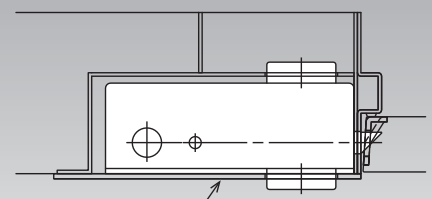

Removable Cover Plate (by others)

7056SM

Removable Cover Plate (by others)

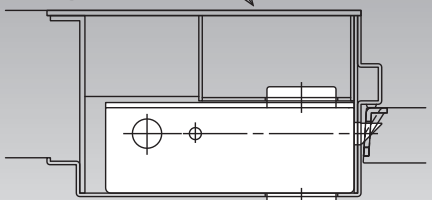

Secure Side

7056SM



**R.R. BRINK LOCKING SYSTEMS, INC.**  
500 Earl Road • Shorewood, IL 60404  
Tel: 815-744-7000 • Fax: 815-744-7020  
www.rrbrink.com

### Application

- The 7050SM solenoid actuated lock is an extra heavy weight electromechanical lock for use in openings subject to high traffic and/or where maximum attack resistance is a priority requirement. It is designed for jamb mounting in a grille or hollow metal frame (14 gauge minimum) with a custom fabricated and reinforced lock pocket (a.k.a. mortar box).
- The 7050SM is recommended for remote control of maximum security locations in jails or prisons (e.g. cells, dayroom entries, and sally ports) or in other building types where openings in security perimeters must be equipped to withstand forced attack and/or constant usage.

- Electric unlocking is accomplished by a 120 VAC solenoid actuator. Latch retraction is snappy and accompanied by a noticeable clap sound.
- Mechanical latch retraction is by pin tumbler RRBLS Mogul key cylinder.
- With a hollow metal frame, the lock mechanism can be serviced with the lock in the frame by removing an access plate supplied by the frame manufacturer (see illustrations above).
- When used in exterior locations, moisture proofing of the lock enclosure is essential and an internal resistance-heating strip is recommended when the lock may be subjected to extreme freezing conditions.



# 7050SM

## Maximum Security, Heavy Duty Electromechanical Deadlocking Latch For Swinging Doors

120 VAC Solenoid Actuated – RRBL5 Mogul Key Cylinder – Jamb Mounted

### Standard Features

- Key unlocking at all times with an RRBL5 Mogul key cylinder.
- Lock case and cover made of 7 gauge steel, electroplated for corrosion resistance
- Working parts are copper alloy or stainless steel.
- A case hardened, zinc-plated steel latch (highly resistant to wear and sawing) with a full 3/4"-inch throw. 3/4" x 2" cross section at the locking shear point.
- Electroplated steel roller bolt deadlocks latch.
- Maintained Switch Latch Holdback (**MSLH**) function (see "Lock Function Reference Guide")
- Lock status switch (**LSS**) trips when the latch is in a deadlocked condition. Used in a signal circuit to indicate lock status – unlocked or deadlocked – via control panel lights and/or alarm devices. The LSS is also used to control an electrical interlock, which permits only one of a group of doors to be unlocked electrically at any time. *Note: For positive, tamper resistant signaling of a closed and deadlocked door, a sensitive door position (DPS) switch must be wired in combination with the LSS. Our DPS Nos. 201030 or 201090 are recommended.*
- Plug connectors are provided for ease in wiring and removal.
- Exposed fasteners – pinned "Torx" head

### Electrical Data

- Solenoid – 120VAC – Laminate Design – Intermittent Duty – 60Hz standard – 10 ampere in-rush, 0.75 ampere seated
- NOTE: For applications utilizing 50Hz electrical input, consult factory prior to order. The life cycle of a 60Hz rated solenoid operated with 50Hz current is shortened due to possible overheating. Therefore, a non-standard 50Hz solenoid is recommended, particularly for high usage applications.
- Lock status switch – SPDT type, UL listed, 125/250 VAC, 5 amp.

### 7052SM Illustrated

Hinge-side mounting. Keyed one side

Note: This illustration is for information only. Do not use for construction. Door and frame preparation drawings and wiring schematics are available from the factory.

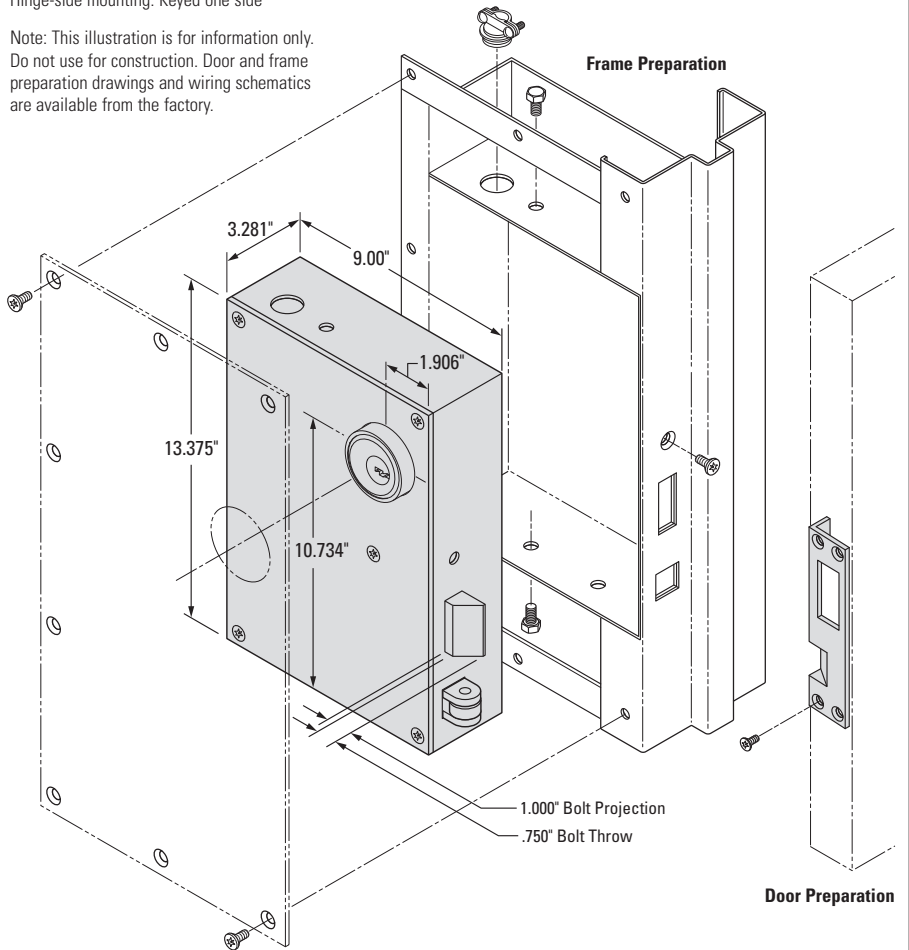

Underwriters Laboratories, Inc. listing as a fire door accessory. Listing is for a 3-hour fire door (UL-10B). Also UL listed as a "Burglary Resistant Electric Locking Mechanism" (UL-1034).

Certified by a nationally recognized independent testing laboratory to meet ASTM F1577-6.2- Impact Test Grade 1

### Custom Applications

Consult with our technical service personnel regarding custom applications such as retrofits to existing lock installations, special mounting situations and operational requirements.

### Optional Accessories

- Custom bolt projection – consult factory

### Ordering Information

#### 7050MS – Solenoid Actuated Series

Model	Description
7052SM	7050SM keyed one side
7056SM	7050SM keyed both sides



### R.R. BRINK LOCKING SYSTEMS, INC.

500 Earl Road • Shorewood, IL 60404  
Tel: 815-744-7000 • Fax: 815-744-7020  
www.rrbrink.com

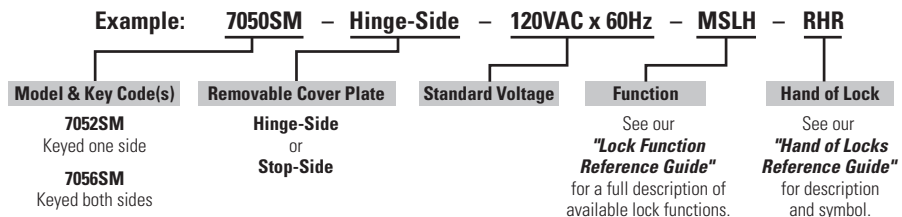

# 7060

## Lever-Tumbler Mechanical Deadlatch for Swinging Doors



7060



7060K with optional knob



*Investment cast  
prison paracentric  
key (must be ordered  
separately)*

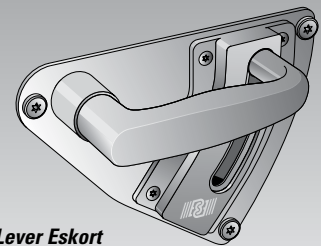

*Lever Eskort  
Escutcheon and Track  
Assembly for 7060L*



**Keeper/  
Strike  
K**

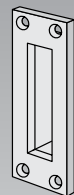

**Keeper w/  
Dust Box  
KD**

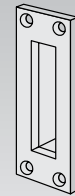

**Keeper w/  
Indication  
Switch  
KS**

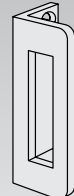

**Surface  
Applied  
KSA**

*Bolt Keepers (must be ordered separately)*



**R.R. BRINK LOCKING SYSTEMS, INC.**  
500 Earl Road • Shorewood, IL 60404  
Tel: 815-744-7000 • Fax: 815-744-7020  
www.rrbrink.com

### Application

The 7060 is a lever-tumbler latch appropriate for jail and prison holding cells, storage rooms, and passage doors where the convenience of slam locking makes it preferable to the RRBS 7080 deadbolt. Unlocking and locking of the beveled bolt is by an RRBS paracentric key. When a door is closed, deadlocking of the 7060 requires *two* revolutions of the key. It is important that correctional officers

observe this requirement to avoid a security breach by clandestine latch retraction with end force (e.g. "carding").

As an option, the 7060 is available with latch retraction by knob or "Lever Eskort" (see inset above) sets. These models are designated 7060K and 7060L, respectively. When the latch is deadlocked by two turns of the key, the knobs or levers are rendered inactive, i.e. rigid.

# 7060

## Lever-Tumbler Mechanical Deadlatch for Swinging Doors

### Standard Features

- Industry standard template
- Cast ductile iron lock case, zinc plated
- Investment cast, bronze alloy, one-piece key cylinder
- Zinc plated steel deadlatch with two hardened steel inserts
- Six hard brass lever tumblers
- Heavy bronze tumbler spring
- Random-depth key cuts impede "picking"
- Lever tumblers are provided with "anti-pick" notches for both locked and unlocked condition
- Latch throw: 3/4"
- Latch retracted projections: 1/2" (with hinge side mounting); 1-1/4" (with stop side mounting).
- Latch size: 2" x 3/4".
- Four mounting screws included

### Accessories (must be ordered separately)

- **Prison paracentric key** – Investment cast bronze alloy – specify number of keys required
- **Bolt keepers**
  - K** standard mortise
  - KD** mortise with dust box
  - KS** mortise with indication switch
  - KSA** surface applied
- **Escutcheon**
  - Satin Stainless Steel – (ANSI 630, US32D)
  - Satin Brass – (ANSI 606, US4)
- **Cylinder shield** – A surface applied flap which closes off the keyway to outside debris at exterior locations – ANSI 630, US32D finish only.

### Lock Mountings (must be ordered separately)

The 7060 lock should be encased and protected on the door with an appropriate steel mounting. Mountings are constructed of 7-gauge steel with an electroplated finish for corrosion resistance. Mountings are removable for cleaning and repair of lock. Escutcheons must be purchased separately. All mounting screws are included. Consult factory directly for template of lock mountings.

- **Hollow Metal Mounting** (specify HM Mounting) – for use on hollow metal doors.
- **Plate Mounting** (specify P Mounting) – for use on steel plate doors. Allows lock to be rim-mounted.
- **Grille Mounting** (specify G Mounting) – for use on grille (steel bar) type doors. Designed for welding to grille.



### R.R. BRINK LOCKING SYSTEMS, INC.

500 Earl Road • Shorewood, IL 60404  
Tel: 815-744-7000 • Fax: 815-744-7020  
www.rrbrink.com

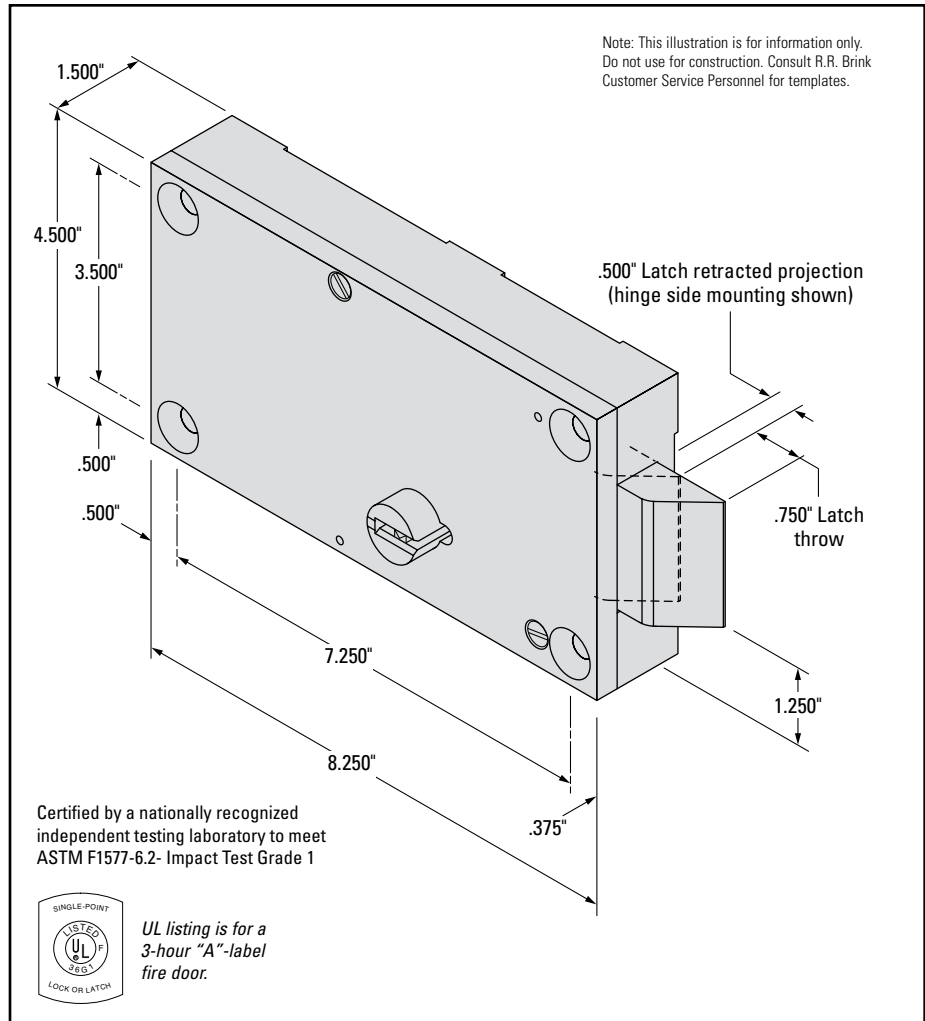

### Ordering Information

Model	Description	Latch Retraction
7062	Keyed one side	Paracentric key
7066	Keyed two sides	Paracentric key
7062K	Keyed one side	Knob
7066K	Keyed two sides	Knob
7062L	Keyed one side	Lever Eskort
7066L	Keyed two sides	Lever Eskort

### Security Warning

With lever-tumbler locks keyed on two sides, it is important that the end user always remove the key from a locked door. If the key is left in the lock, for instance on the non-secure side to facilitate frequent unlocking, the bolt can be retracted from the opposite side by simply turning the cylinder with a common tool. (e.g, screwdriver). This poses an unacceptable and potentially dangerous security risk!

### Ordering Example

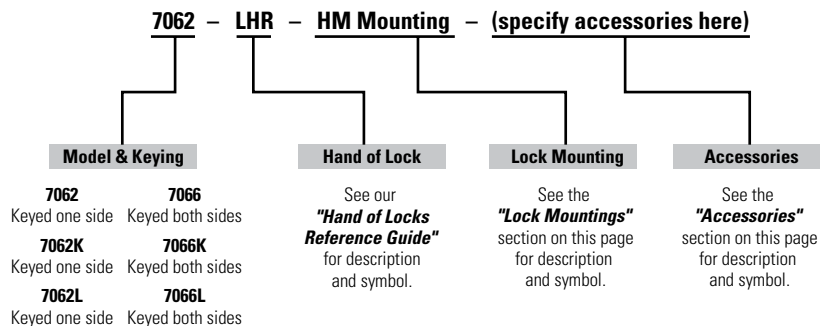

# 7060 & 7060M

## Mechanical Deadlatch for Swinging Doors

The 7060 is operated by lever tumblers via a paracentric key

The 7060M is operated by a pin tumbler Mogul type key



7060M with Mogul cylinder



7060 with lever-tumbler



7060K with optional knob

**Investment cast keys**  
(must be ordered separately)



RRBLS prison paracentric

RRBLS detention mogul

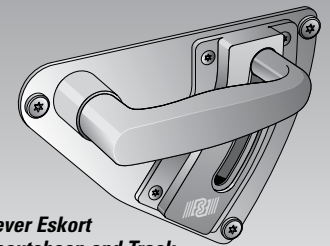

Lever Eskort Escutcheon and Track Assembly for 7060L

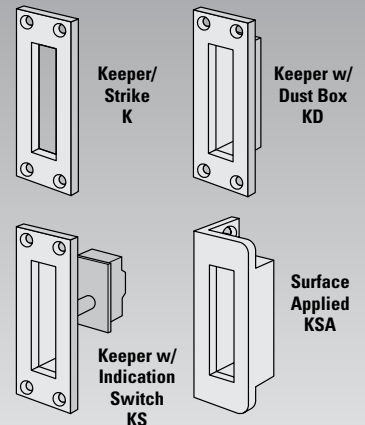

**Bolt Keepers** (must be ordered separately)

### Application

The 7060 is a lever-tumbler latch appropriate for jail and prison holding cells, storage rooms, and passage doors where the convenience of slam locking makes it preferable to the RRBSL 7080 deadbolt. Unlocking and locking of the 7070 beveled bolt is by an RRBSL paracentric key or a 2" diameter pin tumbler key cylinder with the 7060M. The latter version enables master keying that is not available with the paracentric key model.

When a door is closed, deadlocking of the 7060 requires two revolutions of the

key. It is important that correctional officers observe this requirement to avoid a security breach by clandestine latch retraction with end force (e.g. "carding").

As an option, the 7060 is available with latch retraction by knob or "Lever Eskort" (see inset above) sets. These models are designated 7060K and 7060L, respectively. When the latch is deadlocked by two turns of the key, the knobs or levers are rendered inactive, i.e. rigid.

*Note: 7060K & 7060L are shipped with knobs or levers on both sides unless otherwise specified.*



**R.R. BRINK LOCKING SYSTEMS, INC.**

500 Earl Road • Shorewood, IL 60404  
Tel: 815-744-7000 • Fax: 815-744-7020  
www.rrbrink.com

# 7060 & 7060M

## Mechanical Deadlatch for Swinging Doors

### Standard Features

- Industry standard template
- Malleable iron lock case, zinc plated
- 7060 – Integral, bronze alloy investment cast, one piece paracentric key cylinder.  
7060M – fitted for a 2" diameter cylinder - priced separately – see "Key Cylinder" catalog sheet.
- Zinc plated steel deadlatch with two hardened steel inserts
- 7060 – Six hard brass lever tumblers  
Heavy bronze tumbler spring, random-depth key cuts impede "picking", lever tumblers are provided with "anti-pick" notches for both locked and unlocked condition
- Latch throw: 3/4"
- Latch retracted projections:  
1/2" (with hinge side mounting);  
1-1/4" (with stop side mounting).
- Latch size: 2" x 3/4".
- Four mounting screws included

### Accessories (must be ordered separately)

- **Prison mogul and paracentric key** – Investment cast bronze alloy – specify number of keys required
- **Bolt keepers**  
K standard mortise  
KD mortise with dust box  
KS mortise with indication switch  
KSA surface applied
- **Escutcheon**  
Satin Stainless Steel – (ANSI 630, US32D)
- **Cylinder shield** – A surface applied flap which closes off the keyway to outside debris at exterior locations – ANSI 630, US32D finish only.

### Lock Mountings (must be ordered separately)

The 7060 lock should be encased and protected on the door with an appropriate steel mounting. Mountings are constructed of 7-gauge steel with an electroplated finish for corrosion resistance. Mountings are removable for cleaning and repair of lock. Escutcheons must be purchased separately. All mounting screws are included. Consult factory directly for template of lock mountings.

- **Hollow Metal Mounting** (specify HM Mounting) – for use on hollow metal doors.
- **Plate Mounting** (specify P Mounting) – for use on steel plate doors. Allows lock to be rim-mounted.
- **Grille Mounting** (specify G Mounting) – for use on grille (steel bar) type doors. Designed for welding to grille.



### R.R. BRINK LOCKING SYSTEMS, INC.

500 Earl Road • Shorewood, IL 60404  
Tel: 815-744-7000 • Fax: 815-744-7020  
www.rrbrink.com

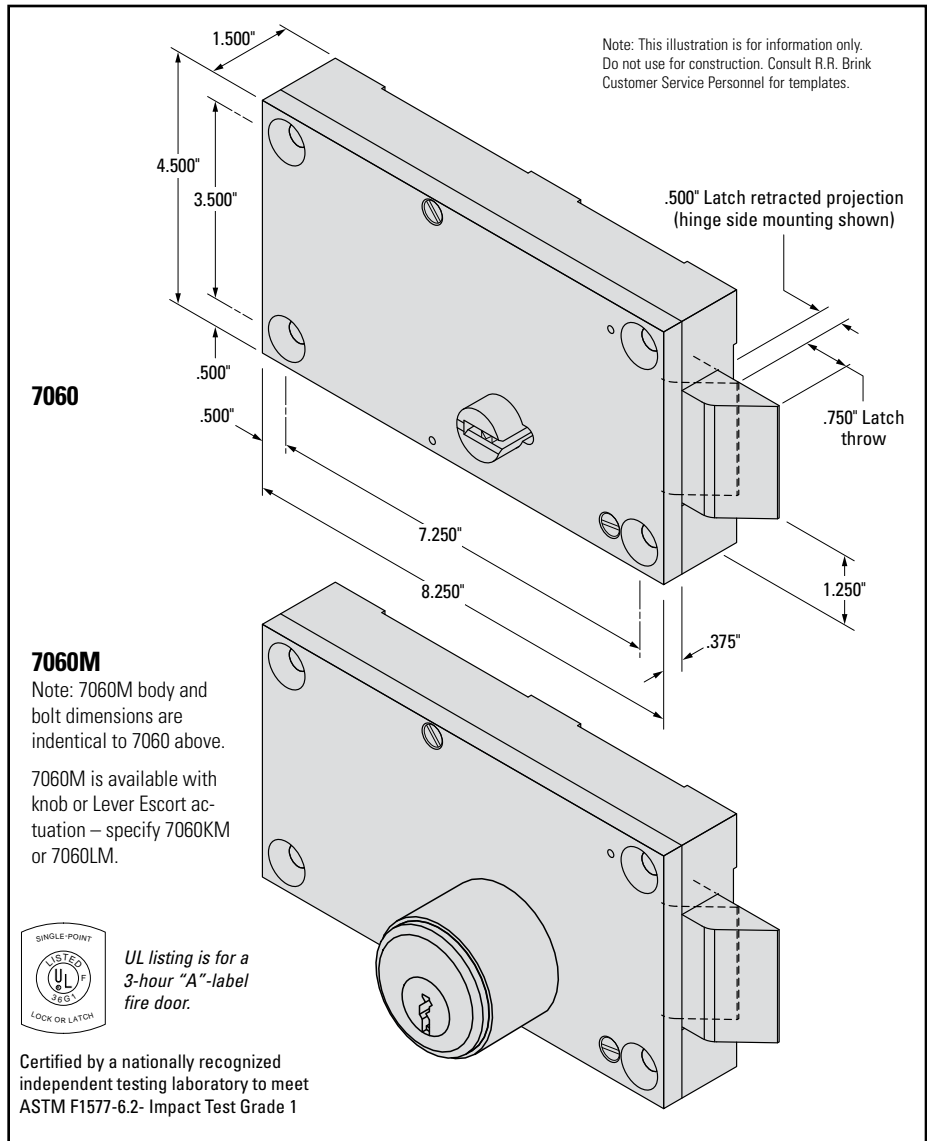

### Ordering Information

Model	Description	Latch Retraction
7062	Keyed one side	Paracentric key
7066	Keyed two sides	Paracentric key
7062M	Keyed one side	Mogul key
	Mogul key not available keyed two side	
7062K	Keyed one side	Knob
7066K	Keyed two sides	Knob
7062L	Keyed one side	Lever Eskort
7066L	Keyed two sides	Lever Eskort

**Warning**  
*With paracentric key operated lever-tumbler locks keyed on two sides, it is important that the end user always remove the key from a locked door. If the key is left in the lock, for instance on the non-secure side to facilitate frequent unlocking, the bolt can be retracted from the opposite side by simply turning the cylinder with a common tool. (e.g, screwdriver). This poses an unacceptable and potentially dangerous security risk!*

### Ordering Example

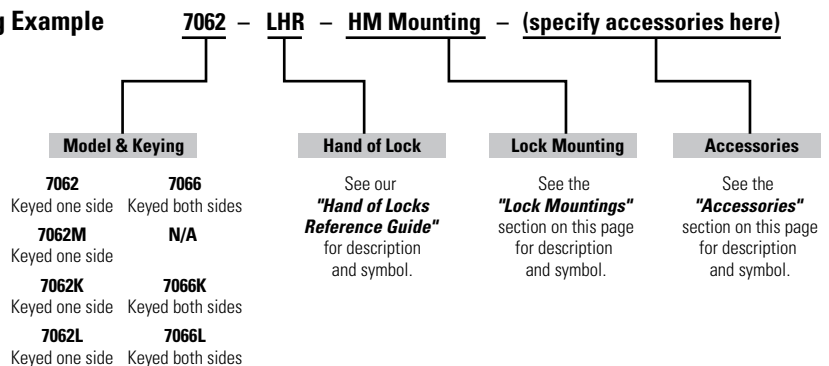

# 7070

## Lever-Tumbler Mechanical Automatic Deadlatch for Swinging Doors



**Investment cast prison paracentric key**  
(must be ordered separately)

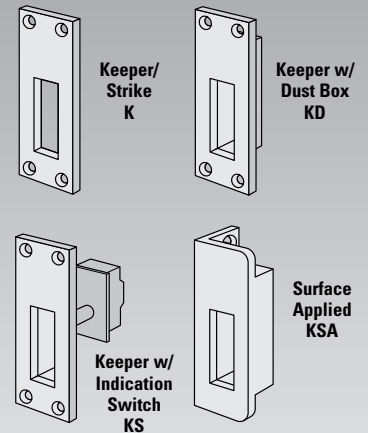

**Bolt Keepers** (must be ordered separately)



**R.R. BRINK LOCKING SYSTEMS, INC.**  
500 Earl Road • Shorewood, IL 60404  
Tel: 815-744-7000 • Fax: 815-744-7020  
www.rrbrink.com

### Application

The 7070 is a lever-tumbler latch with automatic deadlocking via an auxiliary latch. It is used when the convenience of slam closing and automatic (i.e. keyless) deadlocking is of high priority. However, application of the 7070 should be limited to correctional facility locations where inmates should not have unaccompanied access such as high-usage corridor and support room doors (e.g. control, kitchen, laundry, visitation areas).

The 7070 should not be used to secure doors in inmate living areas, especially cells. This is because the 7070 does not

require manual deadlocking by key as do the RRBL Models 7060 latch and the 7080 deadbolt. The automatic deadlocking feature can engender a false sense of security among correctional officers that can be taken advantage of by an inmate surreptitiously obstructing the lock bolt keeper to block full extension of the latch. When this occurs, the automatic deadlocking function is foiled and the latch can be retracted with end force (e.g. carding) to effect a breach of security.

# 7070

## Lever-Tumbler Mechanical Automatic Deadlatch for Swinging Doors

### Standard Features

- Industry standard template.
- s/b ductile iron cast lock case, zinc plated.
- Investment cast, bronze alloy, one-piece key cylinder.
- Zinc plated steel deadlatch with two hardened steel inserts.
- Six hard brass lever tumblers
- Heavy bronze tumbler springs.
- Random-depth key cuts impede "picking".
- Lever tumblers are provided with "anti-pick" notches for both locked and unlocked condition.
- Latch throw: 3/4"
- Latch retracted projections: 1/2" (with hinge side mounting); 1-1/4" (with stop side mounting).
- Latch size: 2" x 3/4".
- Four (4) mounting screws included.

### Accessories (must be ordered separately)

- **Prison paracentric key** – Investment cast bronze alloy – specify number of keys required
- **Bolt keepers** (see illustrations on front page)
  - K standard mortise
  - KD mortise with dust box
  - KS mortise with indication switch
  - KSA surface applied
- **Escutcheon**
  - Satin Stainless Steel – (ANSI 630, US32D)
  - Satin Brass – (ANSI 606, US4)
- **Cylinder shield** – A surface applied flap which closes off the keyway to outside debris at exterior locations – ANSI 630, US32D finish only.

### Lock Mountings (must be ordered separately)

The 7070 lock should be encased and protected on the door with an appropriate steel mounting. Mountings are constructed of 7-gauge steel with an electroplated finish for corrosion resistance. Mountings are removable for cleaning and repair of lock. Escutcheons must be purchased separately. All mounting screws are included. Consult factory directly for template of lock mountings.

- **Hollow Metal Mounting** (specify HM Mounting) – for use on hollow metal doors.
- **Plate Mounting** (specify P Mounting) – for use on steel plate doors. Allows lock to be rim-mounted.
- **Grille Mounting** (specify G Mounting) – for use on grille (steel bar) type doors. Designed for welding to grille.



### R. R. BRINK LOCKING SYSTEMS, INC.

500 Earl Road • Shorewood, IL 60404  
 Tel: 815-744-7000 • Fax: 815-744-7020  
 www.rrbrink.com

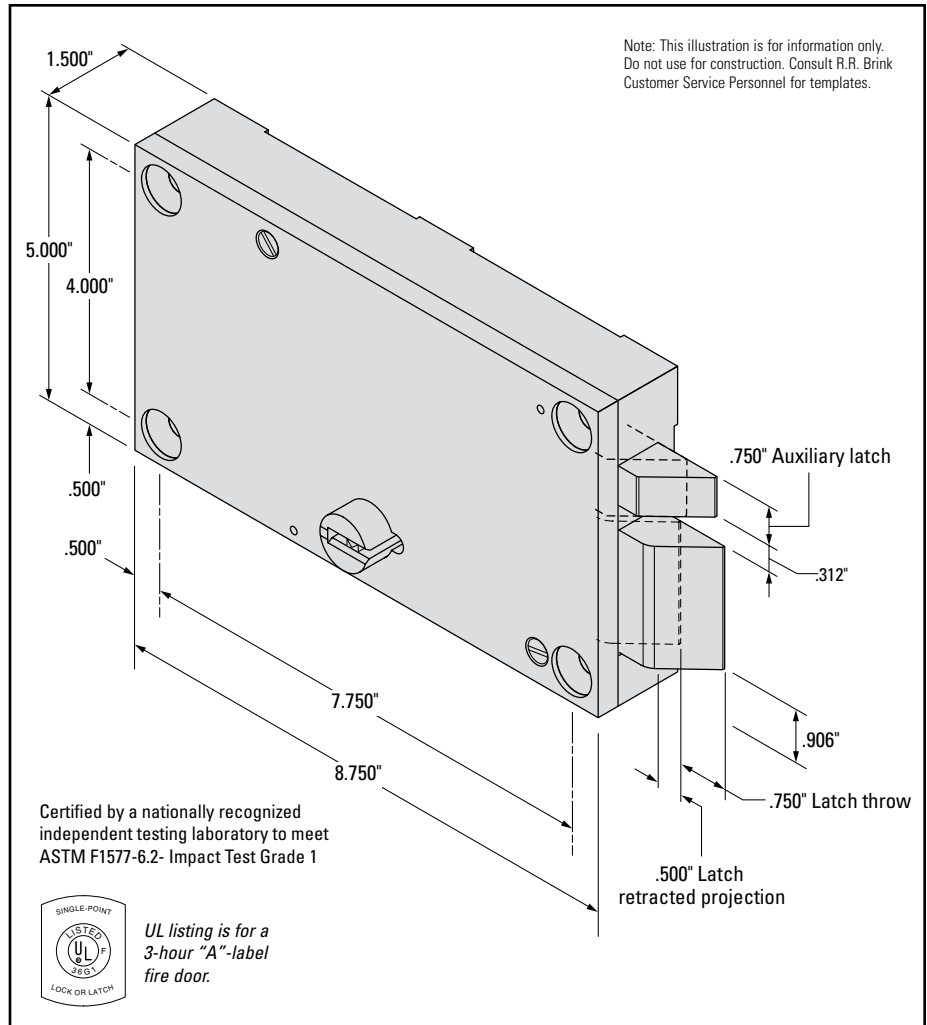

### Ordering Information

Model	Description
7072	Keyed one side
7076	Keyed two sides

### Ordering Example

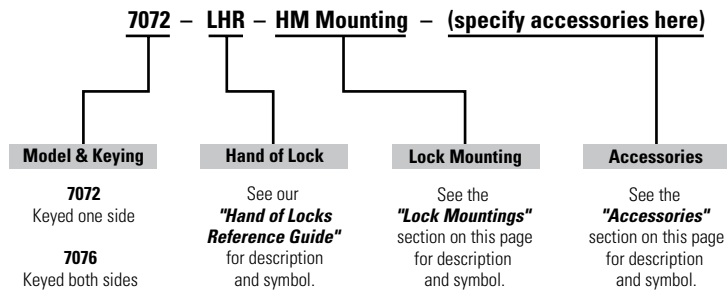

### Security Warning

With lever-tumbler locks keyed on two sides, it is important that the end user always remove the key from a locked door. If the key is left in the lock, for instance on the non-secure side to facilitate frequent unlocking, the bolt can be retracted from the opposite side by turning the cylinder with a common tool. (e.g, screwdriver). This poses an unacceptable and potentially dangerous security risk!

# 7070 & 7070M

## Mechanical Automatic Deadlatch for Swinging Doors

The 7070 is operated by lever tumblers via a paracentric key.

The 7070M is operated by a pin tumbler Mogul type key.



7070M – Mogul Key Cylinder



7070 – Lever Tumbler Key Cylinder

*Investment cast keys (must be ordered separately)*



*RRBLS prison  
paracentric*



*RRBLS detention  
mogul*



**Keeper/  
Strike  
K**

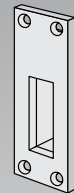

**Keeper w/  
Dust Box  
KD**

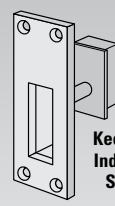

**Keeper w/  
Indication  
Switch  
KS**

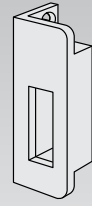

**Surface  
Applied  
KSA**

*Bolt Keepers (must be ordered separately)*



**R.R. BRINK LOCKING SYSTEMS, INC.**

500 Earl Road • Shorewood, IL 60404

Tel: 815-744-7000 • Fax: 815-744-7020

www.rrbrink.com

### Application

The 7070 is a latch with automatic deadlocking actuated via an auxiliary latch (aka deadlock trigger). The 7070 is used when the convenience of slam closing and automatic (i.e. keyless) deadlocking is of high priority. However, application of the 7070 in a correctional facility should be limited to locations where inmates should not have unaccompanied access such as high-usage corridor and support room doors (e.g. control, kitchen, laundry, visitation areas).

**Warning: The 7070 should not be used to secure doors in inmate living areas, especially cells. This is because the 7070 does not require manual deadlocking by key as do the RRBS Models 7060 latch and the 7080 deadbolt. The automatic deadlocking feature can engender a false sense of security among correctional officers that can be taken advantage of by an inmate surreptitiously obstructing the lock bolt keeper to block full extension of the latch. When this occurs, the automatic deadlocking function is foiled and the latch can be retracted with end force (e.g. carding) to effect a breach of security.**



# 7070 & 7070M

## Mechanical Automatic Deadlatch for Swinging Doors

### Standard Features

- Industry standard template.
- Malleable iron cast lock case, zinc plated.
- 7070 – Integral, bronze alloy investment cast, one piece paracentric key cylinder.  
7070M – fitted for a 2" diameter cylinder - priced separately – see "Key Cylinder" catalog sheet.
- Zinc plated steel deadlatch with two hardened steel inserts.
- 7070 – Six hard brass lever tumblers  
Heavy bronze tumbler spring, random-depth key cuts impede "picking", lever tumblers are provided with "anti-pick" notches for both locked and unlocked condition
- Latch retracted projections:  
1/2" (with hinge side mounting);  
1-1/4" (with stop side mounting).
- Latch size: 2" high x 3/4" throw.
- Four (4) mounting screws included.

### Accessories (must be ordered separately)

- **Prison mogul and paracentric key** – Investment cast bronze alloy – specify number of keys required
- **Bolt keepers** (see illustrations on front page)
  - K** standard mortise
  - KD** mortise with dust box
  - KS** mortise with indication switch
  - KSA** surface applied
- **Escutcheon** (7070 only)  
Satin Stainless Steel – (ANSI 630, US32D)
- **Cylinder shield** – A surface applied flap which closes off the keyway to outside debris at exterior locations – ANSI 630, US32D finish only.

### Lock Mountings (must be ordered separately)

The 7070 and 7070M locks should be encased and protected on the door with an appropriate steel mounting. Mountings are constructed of 7-gauge steel with an electroplated finish for corrosion resistance. Mountings are removable for cleaning and repair of lock. Escutcheons must be purchased separately. All mounting screws are included. Consult factory directly for template of lock mountings.

- **Hollow Metal Mounting** (specify HM Mounting) – for use on hollow metal doors.
- **Plate Mounting** (specify P Mounting) – for use on steel plate doors. Allows lock to be rim-mounted.
- **Grille Mounting** (specify G Mounting) – for use on grille (steel bar) type doors. Designed for welding to grille.



### R.R. BRINK LOCKING SYSTEMS, INC.

500 Earl Road • Shorewood, IL 60404  
Tel: 815-744-7000 • Fax: 815-744-7020  
www.rrbrink.com

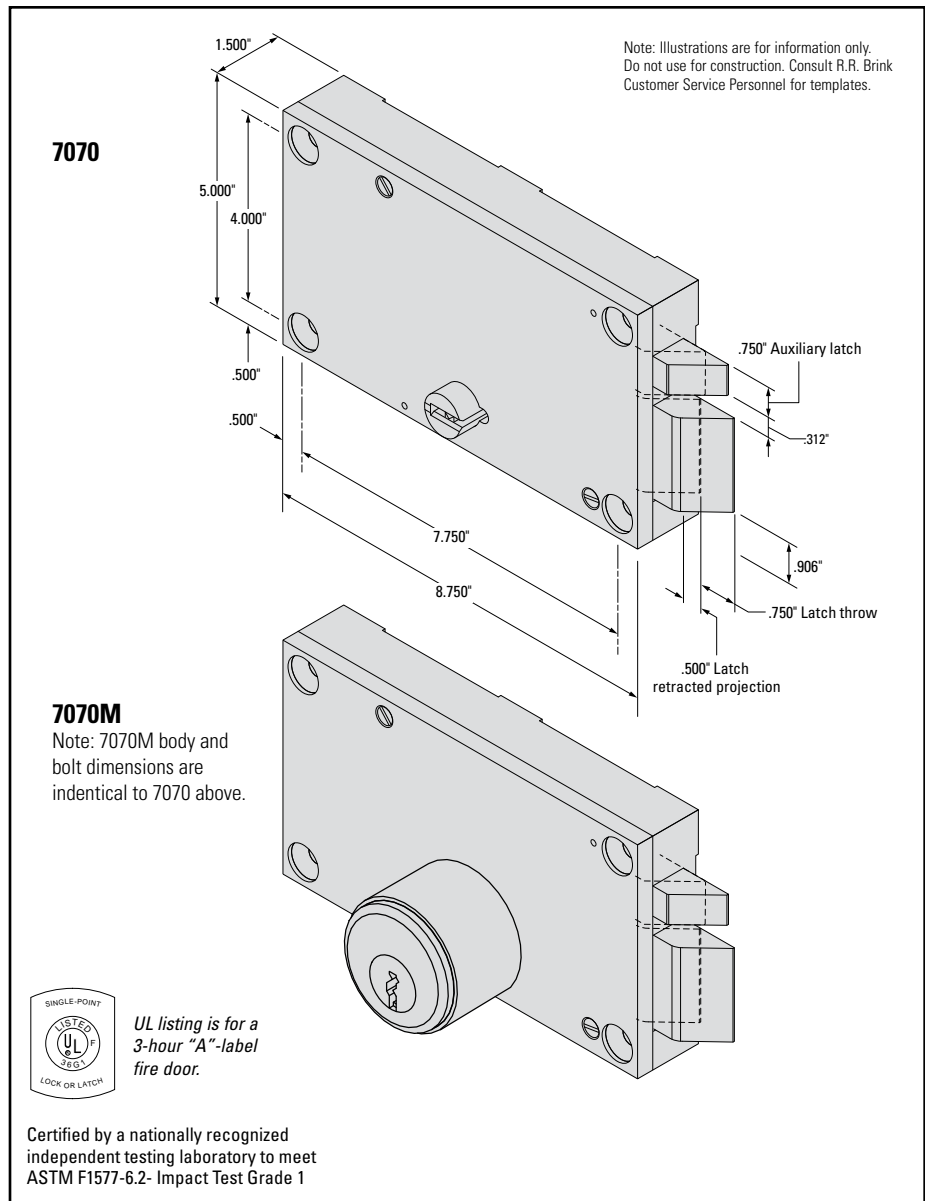

### Ordering Information

Model	Description
7072 or 7072M	Keyed one side
7076	Keyed two sides

### Ordering Example 7072 – LHR – HM Mounting – (specify accessories here)

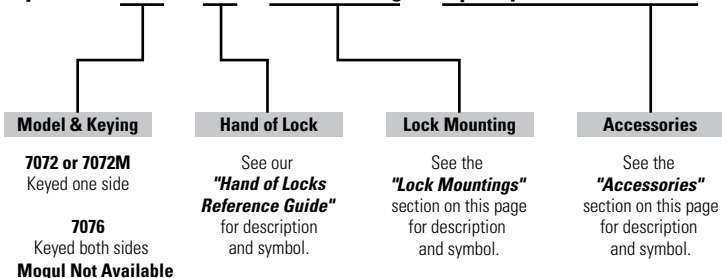

### Security Warning

With lever-tumbler locks keyed on two sides, it is important that the end user always remove the key from a locked door. If the key is left in the lock, for instance on the non-secure side to facilitate frequent unlocking, the bolt can be retracted from the opposite side by turning the cylinder with a common tool. (e.g. screwdriver). This poses an unacceptable and potentially dangerous security risk!

# 7080 & 7080M

**All purpose heavy duty, high security mechanical deadlocks for swinging doors**

7080 is operated by a paracentric key. 7080M is operated by a mogul key.



*Investment cast keys (must be ordered separately)*



**RRBLS prison  
paracentric**

**RRBLS detention  
mogul**

*Bolt Keepers (must be ordered separately)*



**Mortise Bolt Keeper  
7080K**

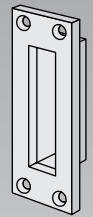

**Mortise Bolt Keeper  
With Dust Box 7080KD**

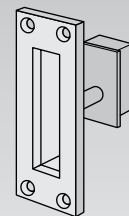

**Mortise Bolt Keeper  
With Indication  
Switch 7080KS**

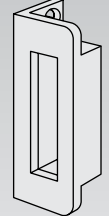

**Surface Applied  
Bolt Keeper 7080SA**



**R.R. BRINK LOCKING SYSTEMS, INC.**  
500 Earl Road • Shorewood, IL 60404  
Tel: 815-744-7000 • Fax: 815-744-7020  
www.rrbrink.com

## **Application**

The 7080 and the 7080M are the industry standard deadbolts widely used in correctional facilities for maximum security key-controlled locking. The 7080 and the 7080M are recommended for openings within the secure perimeter of a jail or prison such as cells, armories, pharmacies, entry and passage doors.

Both locking and unlocking are accomplished with a proprietary RRBLS key – mogul or paracentric.

The key cannot be removed from the lock unless the bolt is fully extended (i.e. deadlocked) or fully retracted. This safety feature alerts the user to an obstruction in the bolt keeper or receiver which might jeopardize security.

The 7080 is independent testing laboratory certified to meet the impact test criteria for Security Grade 1 as set forth in ASTM Standards F1450 and F1577.

# 7080 & 7080M

## Standard Features

- Industry standard template
- Investment cast steel lock case, zinc plated
- 7080 – key cylinder for paracentric key - investment cast of silicon bronze
- 7080M – fitted for a 2" diameter (2.000 x 27 thread) cylinder - priced separately
- Zinc-plated deadbolt with three hardened steel inserts
- 7080 – six brass lever tumblers with "anti-pick" notches and bronze springs
- Bolt retracted projection: 1/2" (for hinge-side mounting), 1-1/4" (for stop-side mounting)
- Bolt size:
  - 7080 – 3/4"W x 2"H with 3/4" bolt throw
  - 7080M – 3/4"W x 1.75"H with 1" bolt throw
- Four mounting screws included

## Accessories (must be ordered separately)

- **MOG** – Model 7080M supplied with RRBS Mogul proprietary 2" diameter, 6-pin detention grade cylinder (UL- 437 listed).
- **Mogul or paracentric keys** – specify number of keys required
- **Bolt keepers 7080 or 7080M**
  - 7080K standard mortise
  - 7080KD mortise with dust box
  - 7080KS mortise with indication switch
  - 7080SA surface applied
- **Escutcheon (7080 only)** – specify one-way or two-way:
 

A one-way escutcheon permits key removal only when the bolt is in the extended (i.e. dead-locked) position; a two-way escutcheon permits key removal in both the locked and unlocked position. Finish: Satin Stainless Steel (ANSI 630, US32D).
- **Cylinder shield (7080 only)** – A surface-applied flap which closes off the keyway to outside debris at exterior locations. Finish: Satin Stainless Steel (ANSI 630, US32D).

## Lock Mountings (must be ordered separately)

The 7080 and 7080M locks should be mounted, enclosed, and protected with an appropriate steel mounting. Mountings are constructed of 7-gauge steel with an electroplated finish for corrosion resistance. Mountings are removable for lock cleaning and repair. Escutcheons must be purchased separately. All mounting screws are included. Consult factory for template of lock mountings.

- **Hollow Metal Door Mounting** – specify 7080HM or 7080MHM Mounting.
- **Plate Door Mounting** – specify 7080P or 7080MP Mounting.
- **Grille Door Mounting** – specify 7080G or 7080MG Mounting. Designed for welding to grille.



## R.R. BRINK LOCKING SYSTEMS, INC.

500 Earl Road • Shorewood, IL 60404  
Tel: 815-744-7000 • Fax: 815-744-7020  
www.rrbrink.com

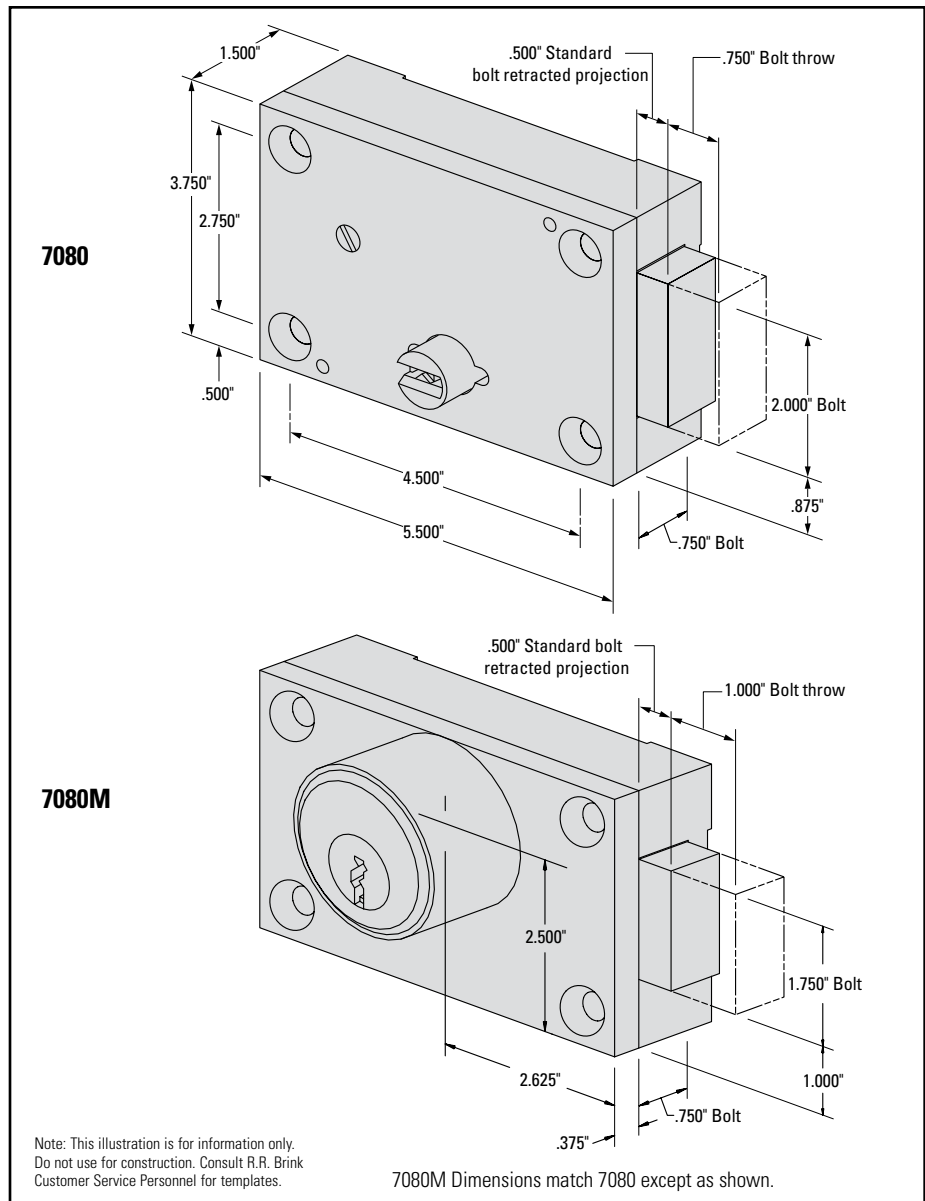

## Ordering Information

Model	Description
7082 or 7082M	Keyed one side
7086 or 7086M	Keyed two sides

## Ordering Example

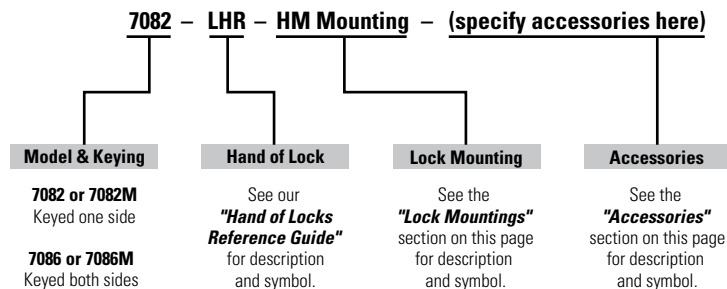

## 7080 Security Warning

With lever-tumbler locks keyed on two sides, it is important that the end user always remove the key from a locked door. If the key is left in the lock, for instance on the non-secure side to facilitate frequent unlocking, the bolt can be retracted on the opposite side by turning the cylinder with a common tool. (e.g. screwdriver). This poses an unacceptable and potentially dangerous security risk!

# 8030 Swinging Gate Lock

## Medium Security Automatic Deadlocking Electromechanical Chain Link Fence Gate Lock

A compact electric or key operated lock for swinging chain link fence gates



8030 gate lock shown in closed position

### Application

The 8030 is a medium-duty electromechanical lock for remote controlled electrical and manual key unlocking of a chain link fence gate. Deadlocking is automatic when the gate is closed manually. Electrical actuation is via a 24VDC solenoid and manual unlocking is by a standard mortise key cylinder supplied by either the factory or the user (e.g. master keyed to an existing system). The 8030 can provide the convenience of remote controlled unlocking for a range of medium security gate lock-ing applications from industrial and institutional enclosures to residential sites. It complements controlled access systems (e.g. card reader and touch pad actuators) where a low voltage/power lock is a requisite.

The 8030 consists of a lock housing designed for fence post mounting. A mating strike enclosure mounts on the gate post and shields the lock front and bolt when the gate is closed. All parts are of corrosion resistant materials (i.e. brass, stainless steel, and galvanized steel). An integral lock status switch provides positive indication of a deadlocked or unlocked bolt via a pilot light and/or alarm circuit.

- Key operation of the 8030 is by a commercial pin tumbler cylinder. This feature facilitates the use of owner-supplied cylinders keyed to an existing system. Specify one or two side keying.

- After initial installation, caulking of the lock enclosure is recommended for weather proofing. Also, at installations subject to freezing conditions, a resistance-heating strip mounted to the internal lock case is recommended to prevent icing of the lock mechanism. (Not Provided by R.R. Brink)



**RR BRINK LOCKING SYSTEMS, INC.**

500 Earl Road • Shorewood, IL 60431  
Tel: 815-744-7000 • Fax: 815-744-7020  
www.rrbrink.com

*Since chain link fence construction varies, RR Brink Locking Systems, Inc. suggests consulting with the factory for each application. Please verify the diameter of fence and gate posts prior to contacting the factory.*

*The 8030 gate lock can be modified for surface application — consult factory.*

## Standard Features

- Electric unlocking actuated by a 24VDC solenoid (1.4 amp in-rush, 0.3 amp seated).
- Manual key operation by a standard mortise cylinder (1-1/8" long) with "Yale" cam and furnished by either the factory or end user. Can be specified for one (K1S) or two (K2S) side keying. Optional factory key cylinder (FKC) is available, see Optional Feature below.
- Lock status switch provides positive indication of a deadlocked bolt (125/250VAC, 5 amp, SPDT)
- Steel lock enclosure and mounting components with electroplated finish. Lock working parts are non-ferrous or stainless steel.
- Lock and strike enclosure mounting brackets are adjustable for 2" to 5" O.D. fence post and 1/2" to 4-1/2" O.D. gate post, respectively. (A nominal 2-1/2" gap between fence and gate posts is required.)
- Field wiring is to quick disconnect plug for ease of installation and maintenance.

## Standard Operation

With electrical control by a momentary switch, the lock bolt will retract (unlock) when power is applied. The latch will stay in the retracted (unlocked) position until power is interrupted when it will project and the gate can be closed and deadlocked automatically. Mechanical unlocking is by key at all times.

## Optional Feature

- Factory supplied key cylinder (FKC)
  - high security mortise brand

# 8030 Swinging Gate Lock

## Medium Security Automatic Deadlocking

## Electromechanical Chain Link Fence Gate Lock

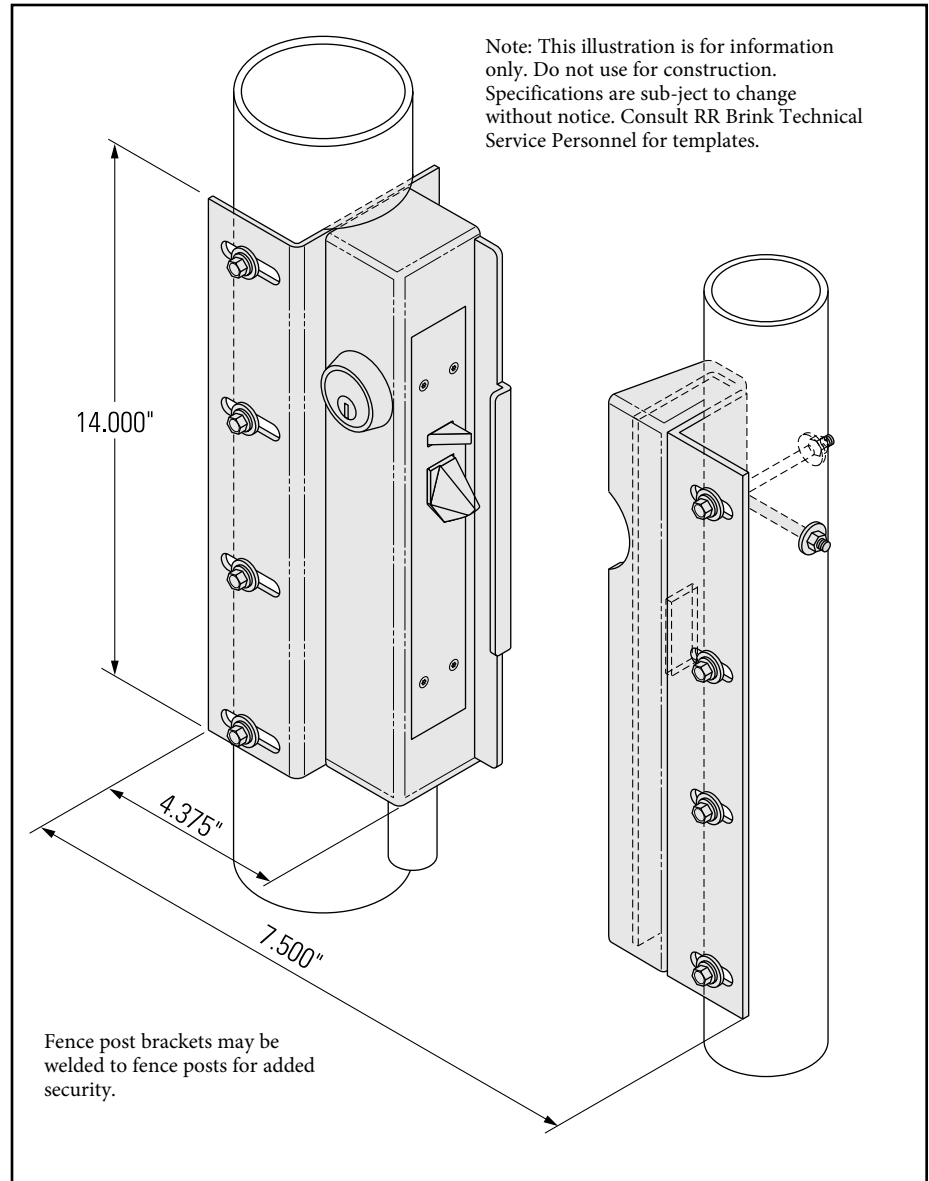

## Ordering Information (required)

When ordering the 8030 Gate Lock please specify the following:

- Lock hand (see "Hand of Locks" page)
- One or two side keying – K1S or K2S
- Outside diameter of gate (GOD) and fence (FOD) posts
- Optional feature - Factory supplied key cylinder – FKC

**Example:** 8030 x FKC x K1S x LHR x 4.0" FOD x 2.0" GOD



**RR BRINK LOCKING SYSTEMS, INC.**

500 Earl Road • Shorewood, IL 60431  
Tel: 815-744-7000 • Fax: 815-744-7020  
www.rrbrink.com

# 8050 Swinging Gate Lock

## High-Security Electromechanical Chain Link Fence Gate Lock

Heavy-duty construction for remote and/or manual key operation



*The 8050 gate lock is shown above in a closed position. When the gate is closed, the locking bolt is completely concealed and the gate and fence are interlocked.*

*Since chain link fence construction varies, R.R. Brink Locking Systems, Inc. suggests consulting with the factory for each application. Please verify the diameter of fence and gate posts prior to contacting the factory.*

*The 8050 gate lock can be modified for surface application — consult factory.*



**R.R. BRINK LOCKING SYSTEMS, INC.**  
500 Earl Road • Shorewood, IL 60431  
Tel: 815-744-7000 • Fax: 815-744-7020  
[www.rrbrink.com](http://www.rrbrink.com)

### Application

The 8050 is a heavy-duty electromechanical lock for a swinging chain link fence gate. Standard electrical operation is by a 120VAC solenoid and manual operation is by a pin-tumbler key cylinder. The 8050 is recommended for high security gate locking at institutional, industrial, commercial and governmental buildings.

The 8050 consists of a lock enclosure designed for fence mounting. A mating gate mounted strike enclosure serves to shield the lock front and bolt when the gate is closed.

As a unique feature when the gate is closed, holes in the strike housing engage with studs in the lock enclosure providing an interlocked connection between the gate and fence to prevent spreading.

All parts are of corrosion-resistant materials (i.e. brass, stainless steel, and galvanized steel). An integral lock status switch provides positive indication of a deadlocked or unlocked bolt via a pilot light and/or alarm circuit.

Key operation is by either a commercial pin-tumbler or prison "Mogul" cylinder. This feature facilitates the use of owner-supplied cylinders keyed to an existing system. Specify one or two side (with key cylinder extension) keying.

After initial installation, caulking of the lock enclosure is recommended for weather proofing. Also, at installations subject to freezing conditions, a resistance-heating strip mounted to the internal lock case is recommended to prevent icing of the lock mechanism. (Not Provided By R. R. Brink)

## Standard Features

- Electric unlocking actuated by a 120VAC solenoid (10 amp in-rush, 1.2 amp seated).
- Manual key operation by a standard mortise cylinder (1-1/8" long) with "Yale" cam and furnished by either the factory or end user.
- One or two side keying – see optional factory key cylinder (FKC), and key cylinder extension (KCE).
- Lock status switch provides positive indication of a deadlocked bolt. Steel lock enclosure and mounting components with electroplated finish. Lock working parts are non-ferrous or stainless steel.
- Lock and strike enclosure mounting brackets are adjustable. For a lock keyed two sides, the fence post outer diameter must be 4" to 5". For a lock keyed one side, the fence post outer diameter must be 2.5" to 5". The gate post outer diameter must be 2" to 4".
- Field wiring is to quick-disconnect plug for ease of installation and maintenance.

## Standard Operation

- With electrical control by a momentary switch, the lock bolt will retract (unlock) when power is applied. The latch will stay in the retracted (unlocked) position until the gate is opened when it will project and the gate can be closed and deadlocked automatically. Mechanical unlocking by key at all times.

## Optional Features

- Factory supplied key cylinder (FKC) – specify standard mortise or Mogul (see Key Cylinder catalog page).
- Key cylinder extension (KCE) – required for two sided keying or for key operation on fence post side opposite the lock mounting. Specify outside diameter of fence post (4" O.D. minimum required). Consult factory if fence post outside diameter is not 4".
- Motor operation (M) – specify for maintained switch control when a gate is to be unlocked (i.e. latch bolt held retracted) for extended periods (see MSLH on "Motor Lock Function" catalog page). Available voltages – 24VDC and 120VAC.

# 8050 Swinging Gate Lock

## High-Security Electromechanical Chain Link Fence Gate Lock

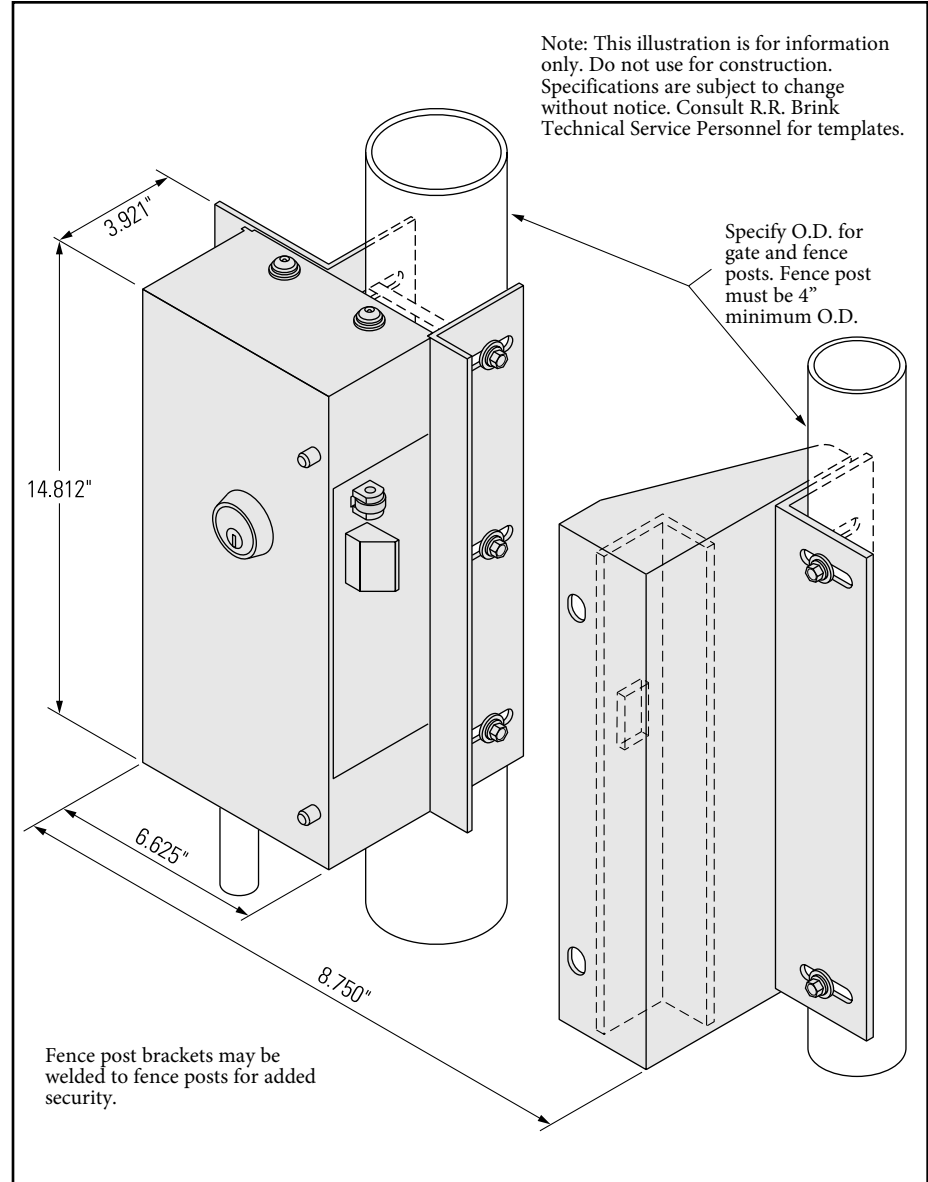

## Ordering Information (required)

When ordering the 8050 Gate Lock please specify the following:

- Lock Hand (see "Hand of Locks" catalog page)
- One or two side keying – K1S or K2S
- Outside diameter of gate (GOD) and fence (FOD) posts
- Optional features

**Example:** 8050 x LHR x FKC-standard x 3.0" GOD x 4.0" FOD x KCE



**R.R. BRINK LOCKING SYSTEMS, INC.**

500 Earl Road • Shorewood, IL 60431  
Tel: 815-744-7000 • Fax: 815-744-7020  
www.rrbrink.com

# 8055 Gate Lock

## High Security Electromechanical Automatic Deadlock

Heavy-duty, remote or manually operated gate lock for sliding chain link fence gate



*8055 gate lock shown in closed and deadlocked position. When the gate is closed, the locking bolt is completely concealed.*

*Since Chain link fence construction varies, R.R. Brink Locking Systems, Inc. suggests consulting with the factory for each application. Please verify the diameter of fence and gate posts prior to contacting the factory.*

*The 8055 gate lock may be modified for surface application — consult factory.*



**R.R. BRINK LOCKING SYSTEMS, INC.**

500 Earl Road • Shorewood, IL 60431  
Tel: 815-744-7000 • Fax: 815-744-7020  
www.rrbrink.com

### Application

The 8055 is a heavy-duty electromechanical lock for a sliding chain link fence gate. Standard electrical operation is by a 120VAC solenoid and manual operation is by a pin tumbler key cylinder. The 8055 is recommended for high security gate locking at institutional, industrial, commercial and governmental buildings.

The 8055 consists of a lock enclosure designed for fence mounting. A mating gate mounted strike enclosure serves to shield the lock front and hook bolt when the gate is closed.

All parts are of corrosion resistant materials (i.e. brass, stainless steel, and galvanized steel). An integral lock

status switch provides positive indication of a deadlocked or unlocked bolt via a pilot light and/or alarm circuit.

Key operation is by either a commercial pin tumbler or prison "Mogul" cylinder. This feature facilitates the use of owner-supplied cylinders keyed to an existing system. Specify one or two side (with optional key cylinder extension) keying.

After initial installation, caulking of the lock enclosure is recommended for weather proofing. Also, at installations subject to freezing conditions, a resistance-heating strip mounted to the internal lock case is recommended to prevent icing of the lock mechanism. (Not Provided by R. R. Brink)



## Standard Features

- Remotely controlled electrical operation by a 120 VAC solenoid (10 ampere inrush, 1.2 ampere seated).
- Fitted for manual unlocking from one or two sides by a standard mortise key cylinder. This facilitates integration into an existing key system. (Factory supplied key cylinders are optionally available.)
- A lock status switch serves to indicate a dead-locked bolt via a control panel pilot light.
- A motor control switch (MCS) allows electrical coordination of the 8055 with a power gate operator where an unlock and door movement sequence is mandatory.
- A plug connector allows for easy electrical hookup and disconnect.
- Interior lock parts are of stainless and electroplated steel.
- The lock and strike mountings are of fabricated steel and electroplated for corrosion resistance.
- The mountings are adjustable for a 3" to 5-1/2" O.D. fence post and 1-1/2" to 3" O.D. gate post. The allowable horizontal clearance between the fence and gate posts is 2-7/8" to 4".

## Standard Operation

- With electrical control by a momentary switch, the bolt will rotate to the unlocked position with application of power. The bolt will remain unlocked until the gate is opened at which point it will be released to the latching position and the gate can be closed and deadlocked automatically. Mechanical unlocking is by key.

## Optional Features

- Factory supplied key cylinder (FKC) – specify standard mortise or Mogul (see Key Cylinder catalog page).
- Motor operation (M) – specify for maintained switch control when a gate is to be unlocked (i.e. latch bolt held retracted) for extended periods (see MSLH on "Motor Lock Function" catalog page). Available voltages – 24VDC and 120VAC.

# 8055 Gate Lock

## High Security Electromechanical Automatic Deadlock

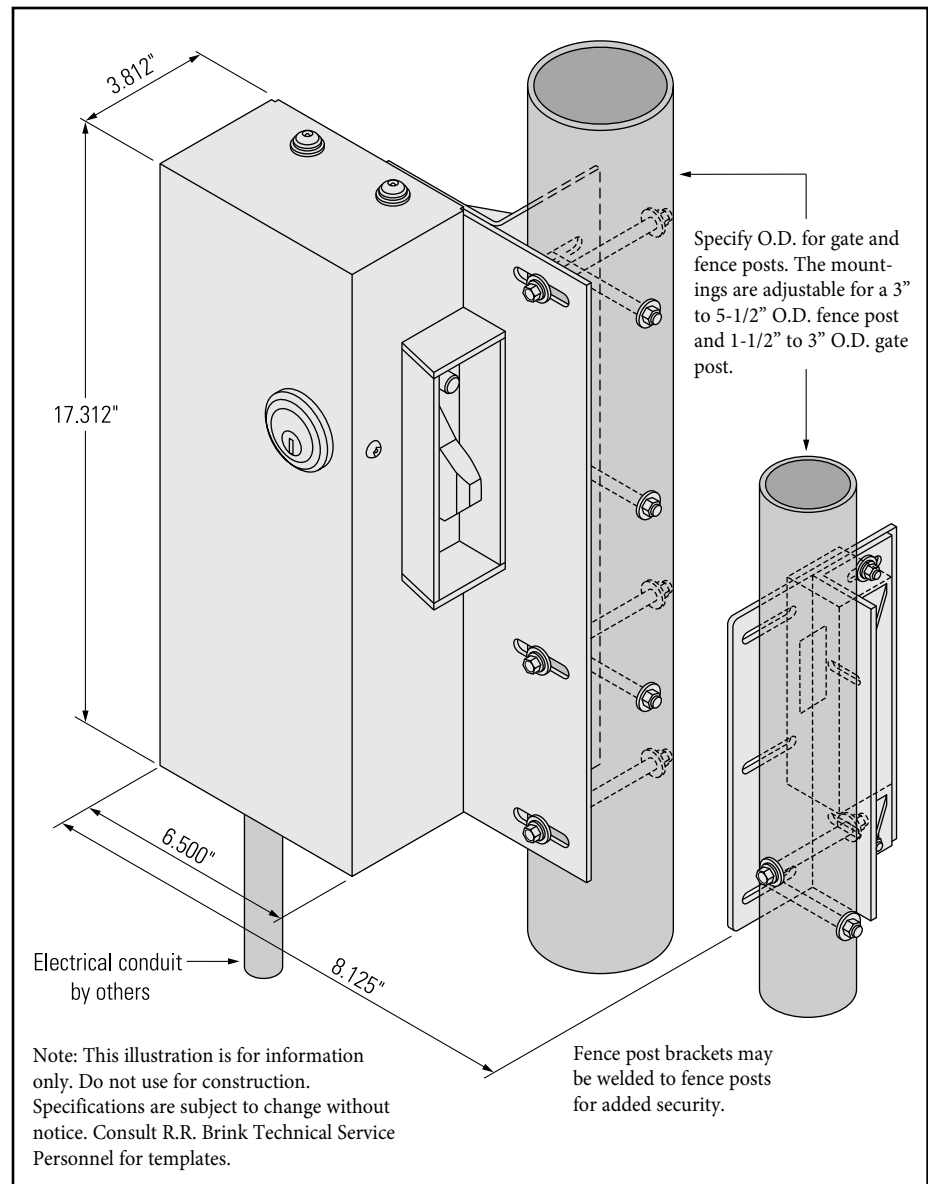

## Ordering Information

When ordering the 8055 Gate Lock please specify the following:

- if factory is to supply key cylinder (standard mortise FKC or Mogul)
- if the lock is to be keyed one or both sides
- the hand (see "Hand of Locks" page)

**Example:** 8055 – FKC – keyed one side – RH



**R.R. BRINK LOCKING SYSTEMS, INC.**

500 Earl Road • Shorewood, IL 60431  
Tel: 815-744-7000 • Fax: 815-744-7020  
www.rrbrink.com

# 9000

## Food Pass/Access Panel Locks Mortise or Surface Applied

9010 Deadbolt fitted for a standard mortise cylinder

9017 Automatic deadlocking latch fitted for a standard mortise cylinder

9025 Automatic deadlocking latch fitted for a Mogul cylinder



9010  
(shown with  
standard  
mortise  
cylinder)



9025 With Mogul Cylinder

9017  
(shown without  
cylinder)



View of 9017/9025 showing  
auxiliary latch (deadlock trigger).



**R.R. BRINK LOCKING SYSTEMS, INC.**  
500 Earl Road • Shorewood, IL 60431  
Tel: 815-744-7000 • Fax: 815-744-7020  
www.rrbrink.com

### Application

The 9000 Series consists of the Model 9010 deadbolt and Models 9017 and 9025 automatic deadlocking latches. In a detention facility, these locks are appropriate for securing utility access doors and small in-door shutters such as a food pass. Commercial building application possibilities are numerous and include the locking of all types of panels that provide access to mechanical spaces. The 9000 Series is not recommended for use on full-size passage doors.

**Model 9010** – A deadbolt requiring key locking and unlocking. It is fitted to accept a standard commercial mortise key cylinder with a "Yale" cam.

**Model 9017** – An automatic deadlocking latch affording the convenience of "slam" locking. It is fitted to accept a standard commercial mortise key cylinder with a "Yale" cam.

**Model 9025** – An automatic deadlocking latch affording the convenience of "slam" locking. It is fitted to accept an RRBSL proprietary Mogul key cylinder.

# 9000

## Food Pass/Access Panel Locks – Mortise or Surface Applied

### Standard Features 9010 and 9017

- Aluminum bronze lock case.
- Bolt (9010), latch (9017), springs, pins, and screws are stainless steel.
- 9010 bolt dimensions  
Throw: 5/8" (mortise 9/16") 1/2" projection when bolt is retracted. Bolt width 1"
- 9017 latch dimensions  
Throw: 5/8" (mortise 9/16") Flush when retracted. Latch width 1"
- Case dimensions: 3" x 4-1/4" x 1-1/4"

- Face plate finishes for mortise mountings:  
Satin Stainless Steel – (ANSI 630, US32D)  
Satin Brass – (ANSI 606, US4)

### Standard Features 9025

- Aluminum bronze lock case.
- Springs, pins, and screws are stainless steel.
- Mogul cylinder
- Latch throw: 5/8". Flush when retracted.
- Latch width 1"
- Case dimensions: 3" x 4-1/4" x 1-1/4"

### Optional Features (must be ordered separately)

- **Factory key cylinder** – (specify FKC and all keying information) high security mortise type with specified finish. Includes cylinder guard ring.
- **Bolt projection** – (for model 9010 only) custom bolt projection for special applications available. Consult factory for recommendations.

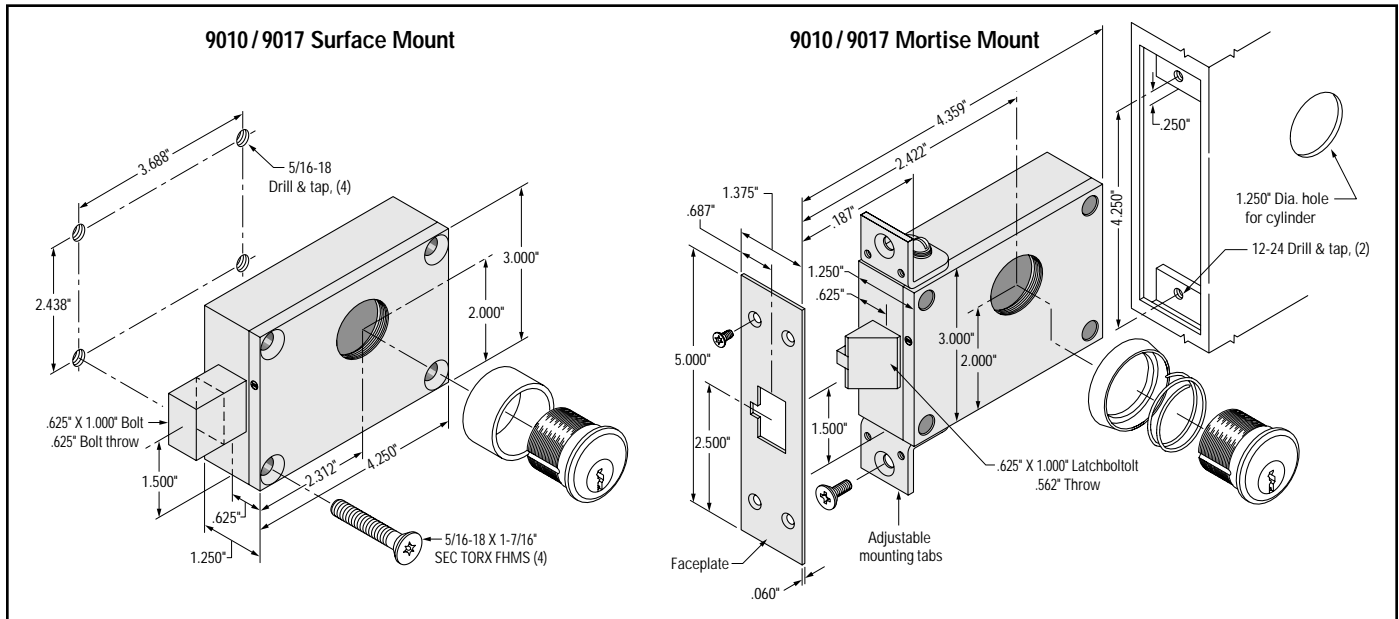

### Ordering Information

Model	Description
9010-1	Keyed one side
9010-2	Keyed two sides
9017-1	Keyed one side
9017-2	Keyed two sides
9025-1	Keyed one side (cover side only)

### Note:

1. 9000 models can be ordered for surface or mortise mounting. The illustration above shows a 9010 in a surface application and a 9017 in a mortise application.
2. Lock illustrations are for information only. Do not use for construction. Consult R.R. Brink Customer Service Personnel for templates.

### Ordering Example

Model & Keying		Hand of Lock	Lock Mounting	Optional
9010-1	9010-2	See our "Hand of Locks Reference Guide" for description and symbol.	M – Mortise	FKC – Factory Key Cylinder
Keyed one side	Keyed both sides		S – Surface	BP – Custom Bolt Projection (model 9010 only)
9017-1	9017-2			
Keyed one side	Keyed both sides			
9025-1	Not Available			
Keyed one side (cover side only)				

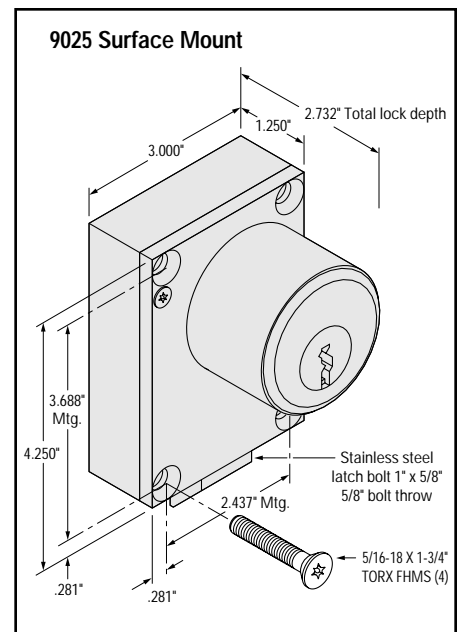

### R.R. BRINK LOCKING SYSTEMS, INC.

500 Earl Road • Shorewood, IL 60431  
Tel: 815-744-7000 • Fax: 815-744-7020  
www.rrbrink.com

# 57100

## Sliding Door Hanger and Track Assemblage

For Manual Sliding Doors and Fence Gates

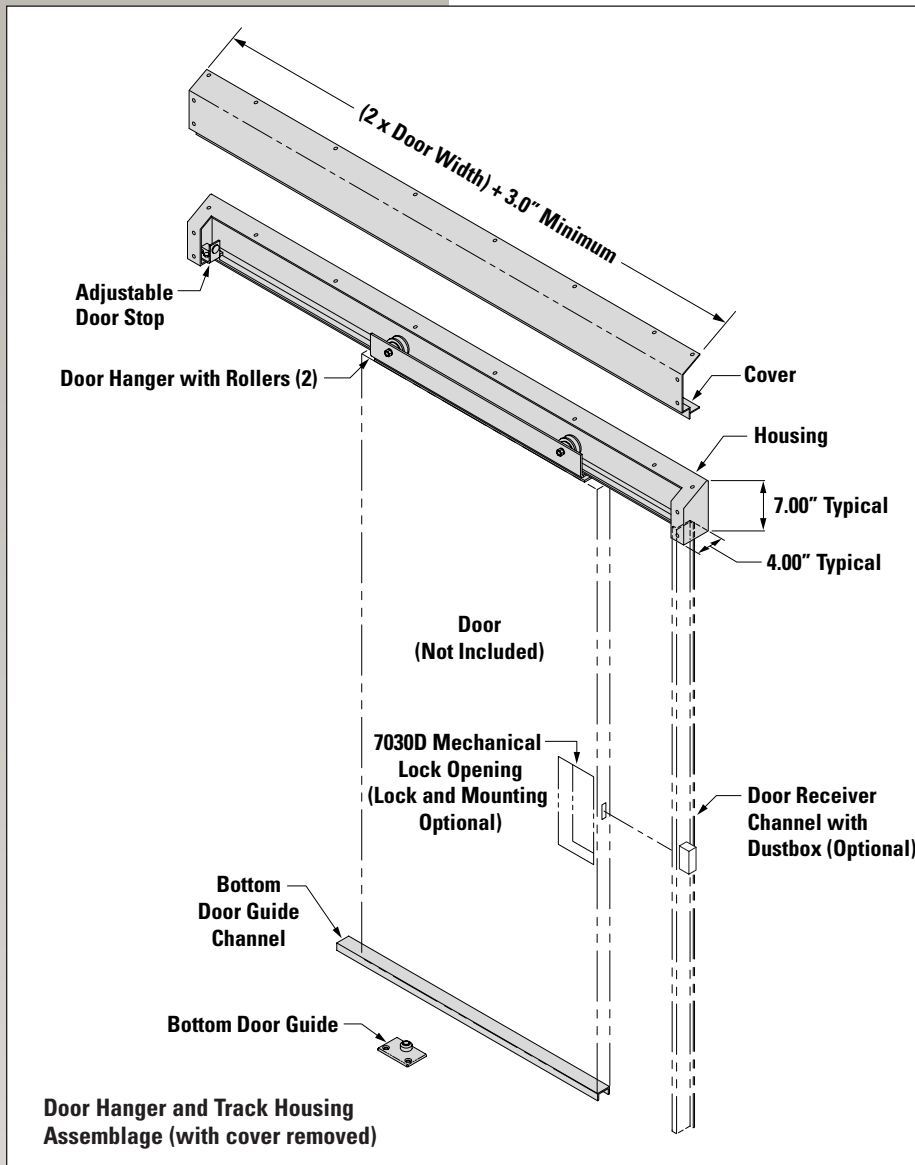

### Standard Features

The 57100 assemblage consists of a sliding door hanger/roller assembly, track enclosure, and bottom guide built for durability and security. A typical application is for police station holding cell doors, often in combination with our 7030 mechanical or 5520 electromechanical locks.

- Construction features include:
  - 7 gauge (3/16") steel track housing
  - 10 gauge (1/8") steel removable housing cover
  - 1/4" thick bent steel plate hanger
  - 3/16" steel channel bottom guide
- Two rollers (2-3/4" diameter) turned from a solid steel bar, hardened and fitted with permanently lubricated steel ball bearings.
- Eccentric roller cams allow for vertical door adjustment.
- Door hanger and bottom guide are designed for welding to the door for optimal security.
- Bottom door guide channel completely conceals floor mounted roller assembly.
- Housing cover attached with security head fasteners.
- Standard housing accommodates door openings from 2'-0" to 3'-0" wide. Custom assemblies are available for doors wider than 3 feet.
- Adjustable heavy duty door bumper stops door movement in open position.
- Gray primer finish.

### Optional Features

- Adjustable spring action door starter.
- A single pole (SPDT) or double pole (DPDT) door position switch.
- Adjustable shock absorber (HSA) cushions the door when slammed against receiver.
- Vertical door receiver channel.
- RRBS lock – see 7030 & 7030D mechanical and 5520 electromechanical locks.

### Ordering Information

- Door Size (width x height x thickness)
- Door Construction (e.g. hollow metal, grille)
- Optional Features
- Consult factory with technical inquires



**R.R. BRINK LOCKING SYSTEMS, INC.**

500 Earl Road • Shorewood, IL 60404  
Tel: 815-744-7000 • Fax: 815-744-7020  
www.rrbrink.com

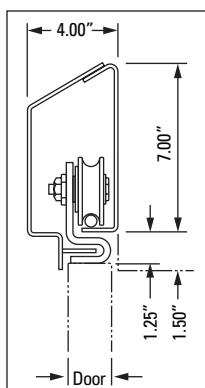

**Typical Door Track and Hanger Profile**

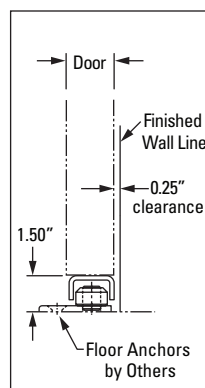

**Bottom Door Guide**

# 57300

## Sliding Door Electric Unlock/Manual Move System

For Medium Security Housing Room Doors in Correctional Facilities

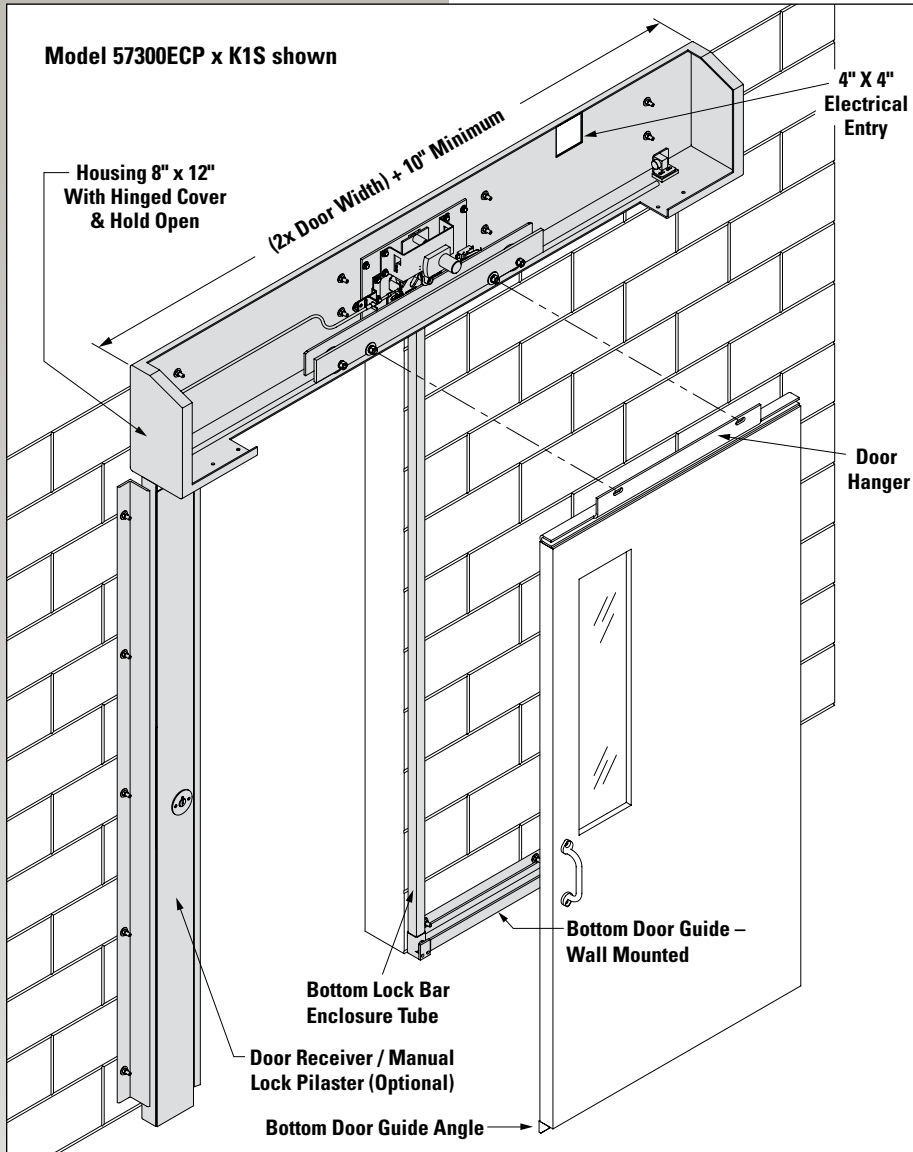

For new construction, the locking mechanism for each door is contained in a fabricated sheet steel housing that wall mounts (see the 57300 schematic drawing at left).

The 57300 must be specified to deadlock the door in both the closed and open positions. RR Brink will NOT sell the 57300 to remain unlocked in the fully open position; the door could potentially be used as a weapon. However, if an open door must first be unlocked either by key or remotely from the control panel before it can be closed and locked, it may impede the ability of a correctional officer to deal with a recalcitrant inmate.

Typically, individual door remote electrical operation of the 57300 is activated from a control room switch console. Cell door rows can be controlled simultaneously or in a pre-selected group. Limit switches located on the mechanism plate serve to signal door condition (i.e. closed/deadlocked or open/unlocked) by pilot lights at the control panel.

A manual means is always provided to enable unlocking without electric power. For cell doors, a remote - manual group release and/or individual door unlocking from the horizontal housing via a tool are typical. Also, individual manual cell door unlocking can be provided via a cable linkage from a hip-high paracentric key lock located in a door receiver pilaster. Likewise, individual electric cell door unlocking can be provided via a hip-high key switch located in a door receiver pilaster (see ordering information below).

### Unitary Design

Electrical and mechanical parts associated with the unlocking of a door are contained on a single plate that is non-handed and, thus, easily replaced irrespective of door travel direction. This feature allows the user to stock one spare mechanism plate as a precaution against a breakdown.

### Built for Durability

All functional components of the 57300 are designed/selected to provide a long life cycle consistent with the frequent use and infrequent maintenance typical in many correctional facility installations. Stamped steel parts are electroplated for corrosion resistance. The door rollers are of hardened steel fitted with permanently lubricated ball bearings.

The gearmotor and switches are standard products of domestic manufacturers and are recognized by independent testing laboratories. They are factory wired to quick-disconnect plugs or terminal strips allowing ease of replacement. The standard 57300 - unit operates on 115VAC line voltage (24VDC is optional).

### Operation and Applications

The 57300 is an electric release/manually moved sliding door locking system (a.k.a. "Kick Release Device") for medium security cells in a correctional institution. Two point, concealed deadlocking is effected at the edge of the door - top and bottom. When electrically activated, the motorized mechanism unlocks a door whereupon it is moved a few inches via a spring load-ed plunger door starter, which also serves to dampen the impact of a closing door. The door can then be fully opened and closed manually. Upon closing, the door deadlocks automatically. An adjustable rubber bumper fixes the open door position.



### R.R. BRINK LOCKING SYSTEMS, INC.

500 Earl Road • Shorewood, IL 60404  
Tel: 815-744-7000 • Fax: 815-744-7020  
www.rrbrink.com

# 57300

## Component Specification

### Standard (and optional) Door Locking and Operating Mechanism Components

- Mechanism Plate – steel plate (9" x 15" x 1/4") contains all functional components for locking and indicating status of a door. The assembly is non-handed and is easily accessible and removable.
- Gearmotor – standard 115VAC & 3 amp – (24VDC & 1 amp available)
- Track – cold drawn steel round (9/16" diameter) welded in place.
- Door hanger – 1/4" formed steel construction with 3/16" vertical adjustment via eccentric bushings (2) and 1" horizontal slotted adjustment to compensate for field misalignments.
- Door rollers – two turned steel wheels (2-3/4" O.D.) fitted with double shielded, permanently lubricated ball bearings. Attachment to door carriage via a high tensile strength steel bolt/lock washer/hex nut.
- Bottom door guide angle and wall guide – 1/4" thick steel construction.
- Top lock bolt – 7/8" diameter stainless steel
- Bottom lock – cast iron body encloses 13/16" diameter stainless steel locking ball.
- Door status indication switch rated at: 15 amp @ 125/250VAC

### Standard Mechanism Housing Material and Construction (w/ 57300)

- Horizontal housing – formed from 3/16" thick steel sheet. Openings are baffled to block the insertion of foreign objects.
- Mechanism access cover – formed from 1/8" thick steel sheet and hinged for easy access. Attachment to the horizontal housing is via pinned Torx security screws.
- Vertical lock bar enclosure – 10 gauge x 1-1/2" square steel tube
- Vertical door receiver/manual lock pilaster (furnished with manual key and/or key switch release optional features) – formed from 3/16" sheet steel with 1/8" steel cover plates attached with pinned Torx security screws. Hard rubber bumpers (2) are incorporated in the 10 gauge receiver surface to cushion the impact of a closing door.
- Housing components – primed for paint.

## Ordering Information:

1. Consult R.R. Brink Locking Systems technical service personnel when planning a 57300 installation. Provide door construction, size and approximate weight. Unless otherwise agreed, it is the responsibility of the R.R. Brink Locking Systems customer (e.g. contractor, end user) to provide accurate field dimensions. Upon acceptance of an order, R.R. Brink Locking Systems will prepare and issue a setting plan drawing for customer approval prior to initial fabrication.  
NOTICE: Unless specifically included by an RRBSL bill of material and/or quotation, miscellaneous metalwork (e.g. masonry mounting plate embeds, closure plates, and shims) is by others
2. The standard R.R. Brink Locking Systems product warranty is for one (1) year from the project turnover date inclusive of defects in factory supplied labor and material only and excludes operational failure due to faulty installation labor by others and/or abusive use.
3. When ordering or specifying the 57300, indicate design choices:
  - \* Line voltage (115VAC standard – 24VDC optional) -
  - \* Door deadlocks in full open and full closed positions.
  - \* Remote mechanical cell row (gang) release from an end-of-row cabinet
  - \* Feature options, as follows:
    - a) No. 57300CD/U typically specified for cell doors with bent plate door receiver (i.e. no vertical manual lock/door receiver pilaster) and mechanical door unlocking from the overhead horizontal mechanism housing. Mechanical unlocking is via paracentric key from the underside of the housing (suffix "U"). (Add a lockable mechanical release cabinet(s) for a cell row(s) requiring all door remote mechanical unlocking. Add wire raceway(s) and, if required, harness(s) for a cell row(s) not designed with individual conduit feeds.)
    - b) No. 57300ECP x K1S (or K2S) – with hip high manual paracentric key lock release in front door receiver pilaster – keyed one (K1S) or two (K2S) sides of doorway.
    - c) No. 57300ECP x K1S (or K2S) x 1KSC (or 2KSC) – same as b) with the addition of a commercial cylinder key switch(s) on one or two sides of doorway.
    - d) No. 57300ECP x K1S (or K2S) x 1KSM (or 2KSM) – same as b) with the addition of a RRBSL mogul cylinder key switch(s) on one or two sides of doorway.
    - e) No. 57300ECP x K1S (or K2S) x 1KSP (or 2KSP) – same as b) with the addition of a RRBSL paracentric cylinder key switch(s) on one or two sides of doorway.



## R.R. BRINK LOCKING SYSTEMS, INC.

500 Earl Road • Shorewood, IL 60404  
Tel: 815-744-7000 • Fax: 815-744-7020  
www.rrbrink.com

# 57700

## Sliding Door Operator for New Installations

A High-Security Locking and Operating System for Correctional Facilities

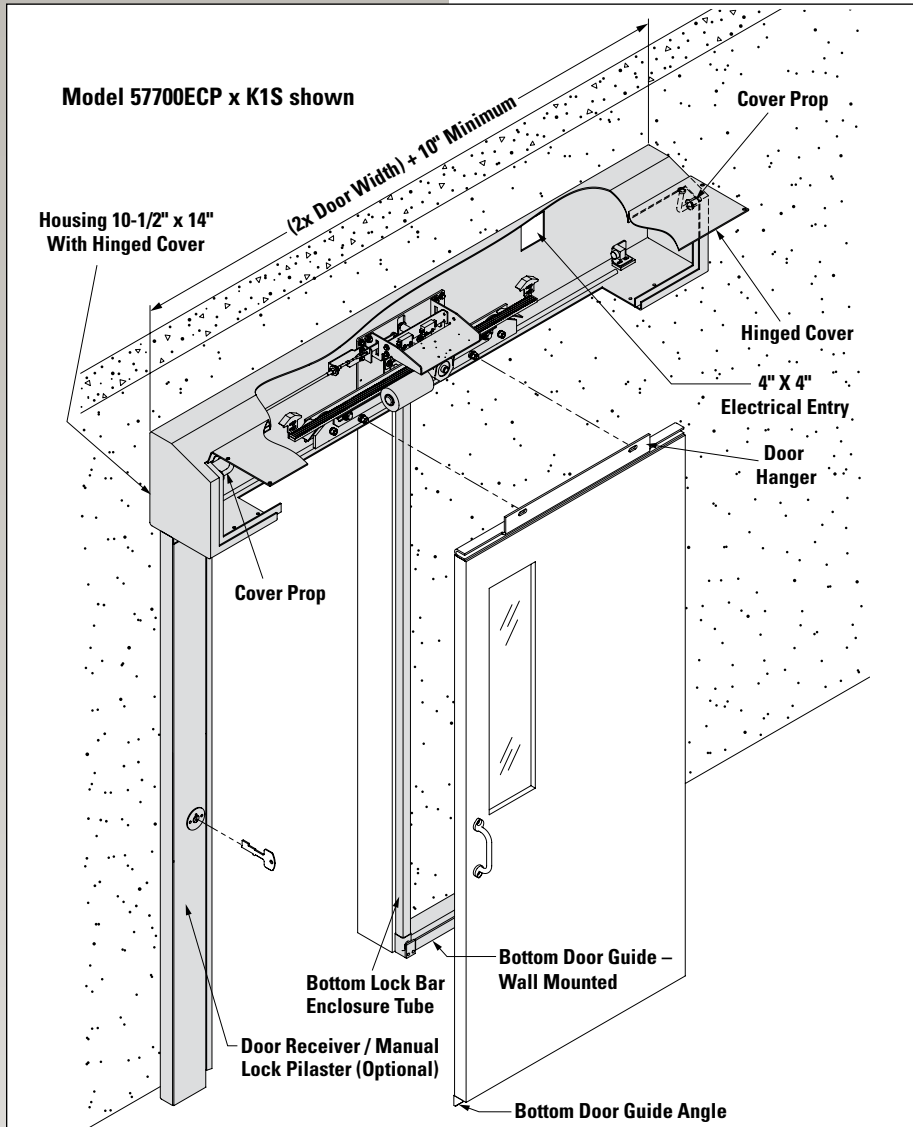

### Built for Durability

All functional components of the 57700 are designed/selected to provide a long life cycle consistent with the frequent use and infrequent maintenance typical in many correctional facilities. Fabricated steel parts are zinc electroplated for corrosion resistance. The door rollers are of hardened steel and turn on permanently lubricated ball bearings.

An R.R. Brink Locking Systems proprietary motor controller and printed circuit relay board serve to control door travel direction and speed. The drive train is clutchless and door travel speed is adjustable electronically by a mechanism plate dial. When a door is blocked intentionally during travel, the pressing force is factory set at approximately 40 lbs and there is no potential for motor/drive train damage. It is possible to reverse door travel direction continuously and instantly without mechanism damage.

The motor, plug-in relays and switches are standard products of domestic manufacturers and are recognized by independent testing laboratories. They are factory wired to quick-disconnect plugs or terminal strips allowing ease of replacement. The standard 57700 unit operates on 115VAC line voltage. The gearmotor is a direct current, permanent magnet type with right angle reducer utilizing permanently lubricated bearings and gearbox. The gearhead power output is 1/8 HP, which is sufficient to unlock and move the weight of standard sized detention type doors. The door is attached to the drive train at all times and is never in a "free wheeling" condition.

### Remote Operation

Typically, individual door remote electrical operation of the 57700 is activated from a control room switch console. A key switch can be provided for electric control at the door. Cell door rows can be controlled simultaneously or in a pre-selected group. Limit switches located on the mechanism plate serve to signal door condition (i.e. closed and deadlocked or open/unlocked) by pilot lights at the control panel).

### Manual Override

A manual means is always provided to enable unlocking without electric power. With a corridor or passage door, it is customary to provide a cable linkage from a hip-high paracentric key lock located in a front door receiver pilaster. With a cell row, individual door unlocking via key or tool from the horizontal mechanism housing and /or remote manual all door (gang) unlocking from an end-of-row cabinet are typical. When manually unlocked, either at the door or remotely, the door can be moved easily by hand pushing. Importantly, the door is not disconnected from the drive train and, therefore, is never in a frictionless or freewheeling condition where slam force can inflict bodily injury to a person in the doorway.

### Applications

The 57700 is used with new construction and for complete replacement of existing sliding corridor and cell door locking and operating devices. The locking and operating mechanism is contained in fabricated sheet steel housings that wall mount.

### Unitary Design

Electrical and mechanical parts associated with the locking and movement of a door are contained on a single plate that is non-handed and, thus, easily replaced irrespective of door travel direction. (This feature allows the user to stock one spare mechanism plate as a precaution against a breakdown.) Two point, concealed deadlocking is effected at the edge of the door – top and bottom – in both the open and closed positions. An adjustable rubber bumper fixes the open door position.



**R.R. BRINK LOCKING SYSTEMS, INC.**

500 Earl Road • Shorewood, IL 60404

Tel: 815-744-7000 • Fax: 815-744-7020

www.rrbrink.com

# 57700

## Component Specification Standard (and optional) Door Locking and Operating Mechanism Components

- Motor drive/lock mechanism plate and door hanger/rack assembly. U.S. Patent No. 6,585,303.
- Mechanism Plate – zinc electroplated steel plate (9" x 15" x 1/4") contains all functional components for locking, operating and indicating status of a door. The assembly is non-handed and is easily accessible and removable.
- Gearmotor – standard 115VAC & 5 amp.
- Rack and pinion drive standard.
- Electric door controls – Door movement speed is adjustable via a mechanism plate knob (rheostat). Trimpots are provided to improve motor speed regulation and to set motor torque (i.e. a door's pressing force). An electro-mechanical clutch and/or mechanical torque limiter are not employed.
- Track – hardened steel round (9/16" diameter) welded in place.
- Door hanger – 1/4" formed steel construction with 3/16" vertical adjustment via eccentric bushings (2) and 1" horizontal slotted adjustment to compensate for field misalignments.
- Door rollers – two solid steel wheels (cell door 2-3/4" O.D., corridor door 3-3/4" O.D.) fitted with double shielded, permanently lubricated ball bearings. Attachment to door carriage via a high tensile strength steel bolt/lock washer/hex nut. Tandem roller assemblies provided for  $\geq 450$ lb door.
- Bottom door guide angle and wall guide – 1/4" thick steel construction.
- Top lock bolt – 7/8" diameter stainless steel
- Bottom lock – cast iron body encloses 13/16" diameter stainless steel locking ball.
- Door status indication switch – 15 amp @ 125VAC

### Standard Mechanism Housing Material and Construction

- Horizontal housing – formed from 3/16" thick steel sheet. Openings are baffled to block the insertion of foreign objects.
- Mechanism access cover – formed from 1/8" thick steel sheet, hinged for easy access and provided with hold-open cover props. Attachment to the horizontal housing is via pinned Torx® security screws. (Optionally, a common lock bar operated from a remote mechanical release cabinet can secure cell row housing covers.)
- Vertical lock bar enclosure – 10 ga. x 1-1/2" square steel tube

- Vertical door receiver/manual lock pilaster (optionally furnished with a manual paracentric key and/or electric key switch hip-high unlock control) – formed from 10 ga. sheet steel with 10 ga. steel cover plates attached with pinned Torx® security screws. Hard rubber bumpers (2) are incorporated in the receiver surface to cushion the impact of a closing door.
- Housing sheet metal – primed for paint. standard. Zinc electroplate (electrogalvanize) finish available when specified (e.g. exterior installations).

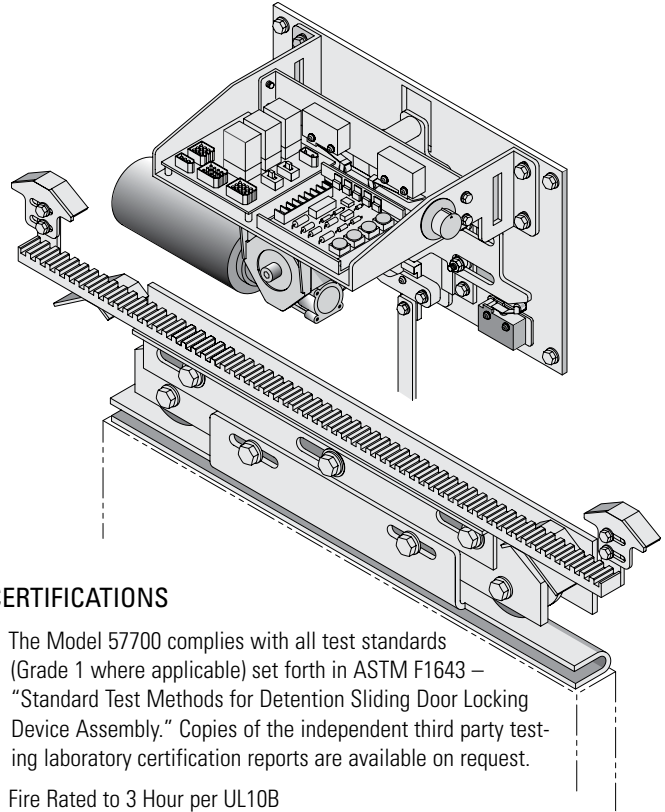

### CERTIFICATIONS

- The Model 57700 complies with all test standards (Grade 1 where applicable) set forth in ASTM F1643 – "Standard Test Methods for Detention Sliding Door Locking Device Assembly." Copies of the independent third party testing laboratory certification reports are available on request.
- Fire Rated to 3 Hour per UL10B

### Ordering Information:

1. Consult R.R. Brink Locking Systems, Inc. (RRBLS) technical service personnel when planning a 57700 installation. Provide door construction, size and approximate weight including glazing (door width and weight limit 6'-0" and 1000lbs, respectively - not suitable for vehicle gates). A door 450lb to 1000lb requires special reinforcement. Unless otherwise agreed, it is the responsibility of the RRBLS customer (e.g. contractor, end user) to provide accurate field dimensions. Upon acceptance of an order, RRBLS will prepare and issue a setting plan drawing for customer approval prior to initial fabrication.  
Standard design devices for cell doors **not** to exceed **300**lbs.  
Standard design devices for corridor doors **not** to exceed **450**lbs.  
For special door size/weight: contact the factory.

NOTICE: Unless specifically included by an RRBLS bill of material and/or quotation, miscellaneous metalwork (e.g. masonry mounting plate embeds, closure plates, and shims) is by others.

2. The standard RRBLS product warranty is the earliest of one (1) year from the project turnover date or eighteen months from shipment date inclusive of defects in factory supplied labor and material only and excludes operational failure due to faulty installation labor by others and/or abusive use (see the RRBLS *Product® Warranty Policy* catalog page).

3. When ordering or specifying the 57700, indicate feature options as follows:
  - a) No. 57700CD/F or U typically specified for cell doors with bent plate door receiver (i.e. no vertical manual lock/door receiver pilaster) and mechanical door unlocking from the overhead horizontal mechanism housing. For latter means, select either unlocking access from the front of the housing via tool from a lockable port (suffix "F") or via paracentric key from the underside of the housing (suffix "U"). (Add a lockable mechanical release cabinet(s) for a cell row(s) requiring all door remote mechanical unlocking. Add wire raceway(s) and, if required, harness(s) for a cell row(s) not designed with individual conduit feeds.)
  - b) No. 57700ECP x K1S (or K2S) – usually specified for corridor/entrance doors with hip high manual paracentric key lock release in front door receiver pilaster – keyed one (K1S) or two (K2S) sides of doorway.
  - c) No. 57700ECP x K1S (or K2S) x 1KSC (or 2KSC) – same as b) with the addition of a commercial cylinder key switch(s) on one or two sides of doorway.
  - d) No. 57700ECP x K1S (or K2S) x 1KSM (or 2KSM) – same as b) with the addition of an RRBLS mogul cylinder key switch(s) on one or two sides of doorway.
  - e) No. 57700ECP x K1S (or K2S) x 1KSP (or 2KSP) – same as b) with the addition of a RRBLS paracentric cylinder key switch(s) on one or two sides of doorway.



### R.R. BRINK LOCKING SYSTEMS, INC.

500 Earl Road • Shorewood, IL 60404  
Tel: 815-744-7000 • Fax: 815-744-7020  
www.rrbrink.com  
Email: rbrink@rrbrink.com



# Security Door Pulls



**300021**  
*Grip Pull*  
*US32D Finish*

**300012**  
*Knob Pull*  
*US26D Finish*

**300011**  
*Flush Cup Pull*  
*US32D Finish*

## **300011-C and 300011-B**

Cast stainless steel flush cup pull serves to limit hand purchase, which could be used to block or hold closed a door. The 300011-C is employed typically on the inmate side of a cell door and attaches to reinforcement strips built into the door. The 300011-B provides back-to-back mounting for two side flush cup pull applications. Available in stainless steel (US32D, ANSI 630) finish.

## **300012**

Solid brass knob pull used as "dummy" trim. Available in satin brass (US4, ANSI 606) and satin chrome (US26D, ANSI 626) finishes. Mounts to reinforcement strips built into the door.

## **300021**

Cast stainless steel grip pull in satin finish (US32D, ANSI 630). Typically used on the corridor side of a cell door and on both sides of corridor connection and access doors.

## Note:

- Security fasteners are provided with pulls.
- Plate mounted pulls and push plates available by special order.



**R.R. BRINK LOCKING  
SYSTEMS, INC.** 500 Earl Road •  
Shorewood, IL 60404 Tel:  
815-744-7000 • Fax: 815-744-7020  
www.rrbrink.com  
Email: rbrink@rrbrink.com

# Security Door Pulls

For swinging inmate room doors in a detention facility, RR Brink recommends the combination of the 300021 and the 300011-C for limited

leverage on room-side pull or the 300011-B for limited leverage on both sides.

## 300021 Grip Pull

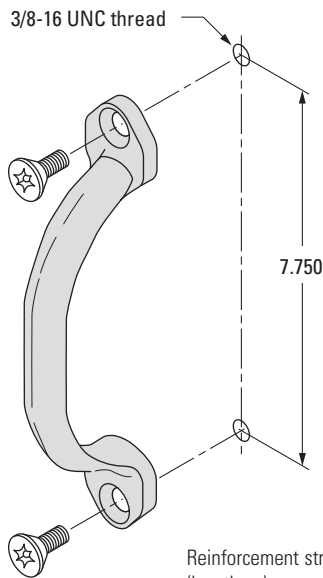

Reinforcement strips in door (by others) are required.

## 300012 Knob Pull

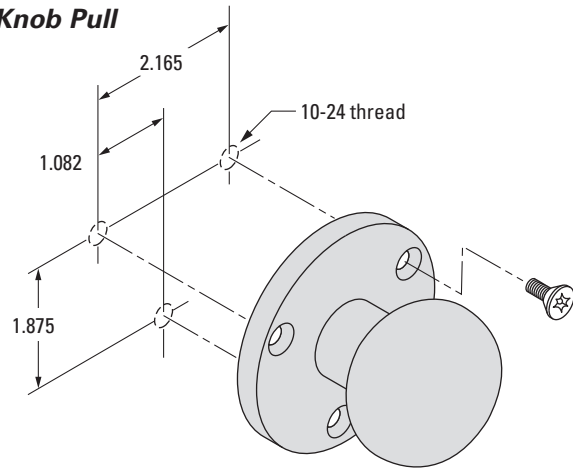

Reinforcement strips in door (by others) are required.

## 300011-C Flush Cup Pull on one side

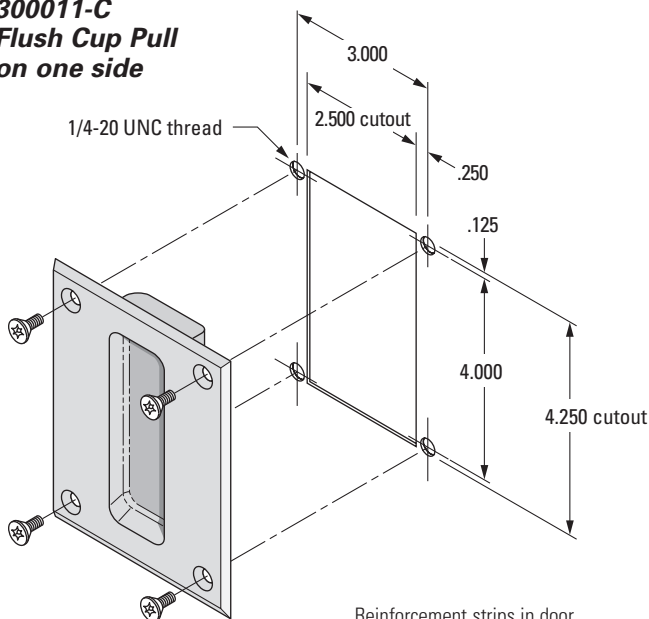

Reinforcement strips in door (by others) are required.

## 300011-B Flush Cup Pull on both sides

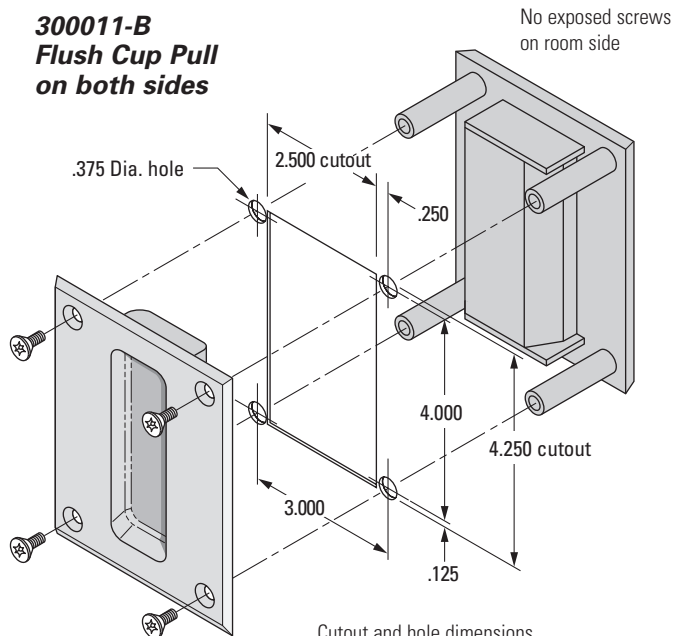

Cutout and hole dimensions are through door thickness.



**R. R. BRINK LOCKING SYSTEMS, INC.**

500 Earl Road • Shorewood, IL 60404

Tel: 815-744-7000 • Fax: 815-744-7020

www.rrbrink.com

Note: The above illustrations are for information only. Do not use for construction. Consult R.R. Brink Technical Service Personnel for templates

# Door Position Switches

- 201030 – Mechanically actuated, mortise mounted.
- 201090 – Mechanically actuated, surface mounted.
- 201020 – Magnetically actuated, mortise mounted.
- 201023 – Triple Biased, magnetically actuated, mortise mounted.

**Model 201030**

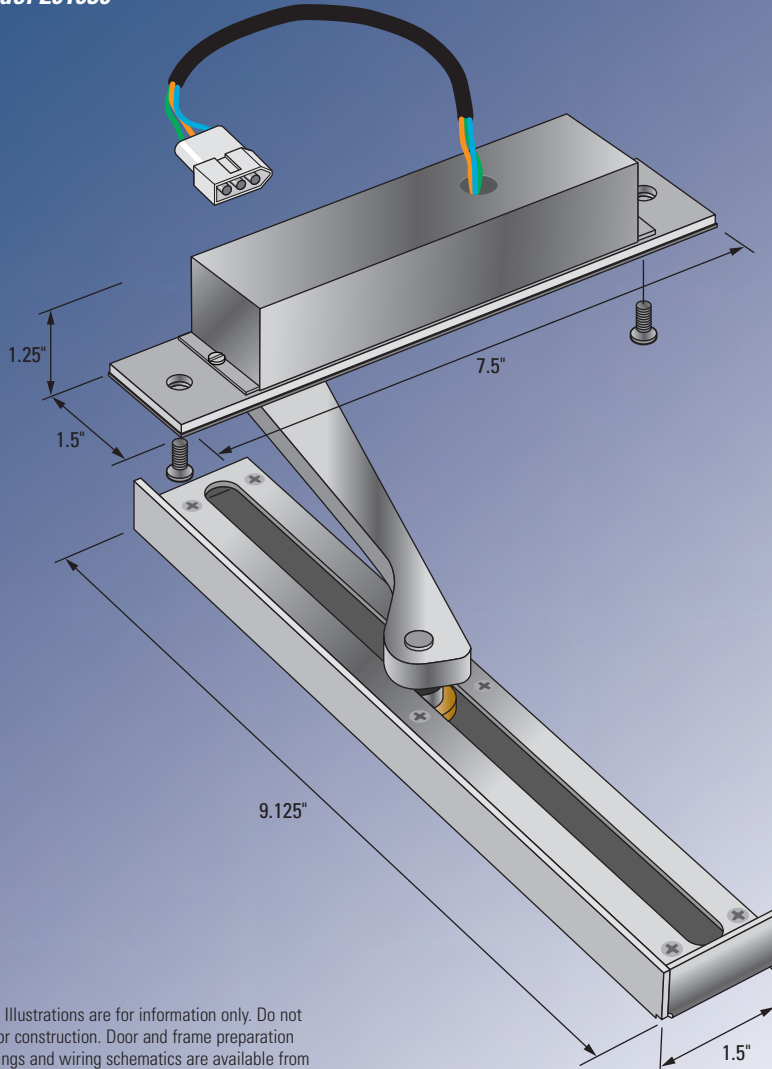

**Model 201090**

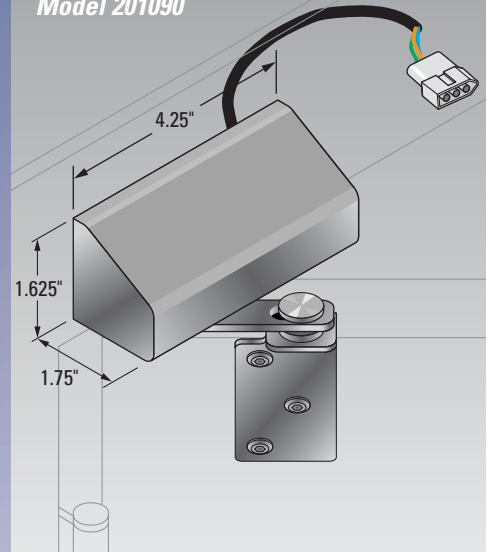

**Model 201020 and 201023**

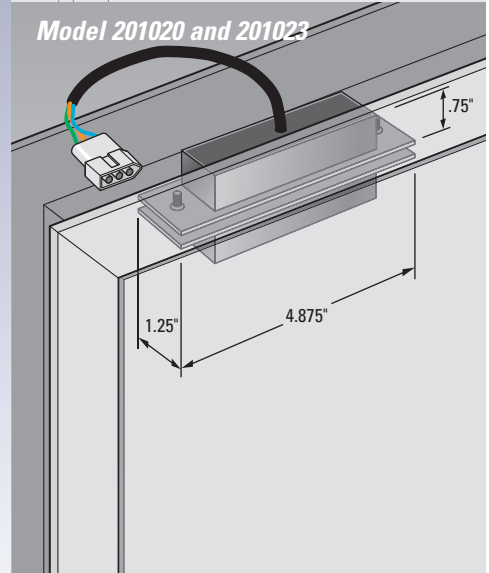

**R.R. BRINK LOCKING SYSTEMS, INC.**  
500 Earl Road • Shorewood, IL 60404  
Tel: 815-744-7000 • Fax: 815-744-7020  
www.rrbrink.com

## The purpose and importance of a Door Position Switch

A typical lock control panel monitor light and/or door interlock circuit is actuated by a "lock status switch" (LSS) and a "door position switch" (DPS). The LSS signals a deadlocked latch bolt and the DPS a closed door. When properly wired together, these switches control indicator lights to signal a secure door (i.e. closed and deadlocked) and/or control an interlock which prevents a door(s) from being electrically unlocked if another door in the group is unlocked.

In the absence of a DPS, the aforesaid circuits are controlled only by the LSS within the lock case. Normally, the LSS is tripped when a door is closed and the

latch bolt is deadlocked by depression of the auxiliary latch (a.k.a. roller or trigger bolt). (When depressed, the auxiliary latch serves to automatically deadlock the latch bolt.) However, an indication/interlock circuit controlled by the LSS only can be compromised easily. That is, when a door is open, the auxiliary latch can be depressed manually which wrongly signals a secure condition. On the other hand, with the LSS/DPS combination, a door must be closed *and* deadlocked to obtain a secure signal. Thus, for positive control of door monitor and/or interlock circuits, a DPS is a requirement.

# Door Position Switches

Available in four different models, the RR Brink door position switches (DPS) provide sensitive door position monitoring.

(Note: See "Ordering Information" [below] for maximum recommended door widths when using an RRBLS DPS in combination with a lock's status switch [LSS] to indicate a closed and locked door condition.)

## 201030 – Mortise Mounted, Mechanical Door Position Switch (DPS)

The Model 201030 DPS is actuated mechanically by movement of the door. With a 4'-0" or narrower door and ANSI door/frame installation tolerances, the switch will trip when the leading edge of the door is within 1/2" of the door stop. It is recommended that the Model 201030 be wired in combination with a lock bolt status switch (LSS) to provide a reliable, tamper resistant control panel monitor (e.g., closed and deadlocked green light) and/or interlock circuit.

The 201030 has two components: 1) a switch unit that mortise mounts in the door frame header with an arm that is connected in the field to, 2) a track that mortises into the upper door edge. When the door is closed and locked, all components are concealed which eliminates the possibility of tampering. A door can be opened to a full 180°. The 201030 has an automatic switch adjustment feature that compensates for differing door and frame alignments (e.g., hinge gauge dimension) without the need for tools or trial and error procedures. Simply closing a door self-adjusts the switch setting.

UNDERWRITERS LABORATORIES, INC. ®  
CLASSIFIED  
MISCELLANEOUS FIRE DOOR ACCESSORY  
7R32

## 201090 – Surface Mounted, Mechanical Door Position Switch (DPS)

The Model 201090 DPS is actuated mechanically by movement of the door. With a 2'-8" or narrower door, the switch will trip when the leading edge of the door is within 3/4" of the door stop. It is recommended that the Model 201090 be wired in combination with a lock bolt status switch (LSS) to provide a reliable, tamper resistant control panel

monitor (e.g., closed and deadlocked green light) and/or interlock circuit.

The 201090 is comprised of two components: 1) a switch housing that is surface mounted on the frame header face and, 2) a switch actuator arm that is surface applied to the hinge side of the door face. A door can be opened to a full 180°. The 201090 has an automatic switch adjustment feature that compensates for differing door and frame alignments without the need for tools or trial and error procedures. Simply closing a door adjusts the switch setting.

### Materials of Construction 201030 and 201090

- Structural and working parts of brass and zinc electroplated steel. (exposed finish ANSI 603, US2G)
- SPDT (Form C) switch – 10 amps @ 250V
- Color coded 7 ft. lead wire harness with quick disconnect at switch unit for ease in installation

## 201020 and 201023 – Magnetic Door Position Switches (DPS) for Mortise Installation

These DPS's employ a reed switch(es) actuated magnetically by movement of the door. It is recommended that the 201020 and 201023 be wired in combination with a lock bolt status switch (LSS) to control a panel monitor (e.g., closed and deadlocked).

The 201020 and 201023 are comprised of two components: 1) a magnet unit that is mortise mounted into the door edge (preferably the top edge adjacent to the lock stile); and, 2) a reed switch unit that is mortised into the door frame opposite and on the same centerlines as the magnet. For proper operation, it is important that the magnet and switch units

align when the door is closed and that the gap between the two units does not exceed 1/4".

The Model 201020 is a single magnet and reed switch unit. When the magnet and switch components are installed as recommended (see installation drawing), the switch will trip when the leading edge of the door is within 1" of the door stop. The 201020 is subject to compromise with a hand held magnet when the door is open. Thus, it is not recommended for use in door openings subject to inmate tampering. Its primary application is in an alarm circuit to signal a door being opened.

The Model 201023 is a triple-biased design employing three reed switches connected in series that are actuated by three magnets in a matched pair configuration. This configuration practically eliminates the possibility of compromise with an external magnet. When the magnet and switch components are installed as recommended (see installation drawing), the switch will trip when the leading edge of the door is within 1/2" of the door stop.

### 201020 Materials of Construction

- Magnet and switch body – Die cast zinc
- Face plates – Clear satin anodized aluminum (ANSI 628, US28)
- SPDT (Form C) switch – 0.5 amps @ 24 V maximum
- Color coded 5 ft. lead wire harness with quick disconnect at switch unit for ease in installation

### 201023 Materials of Construction

- Magnet and switch body – Formed stainless steel
- Face plates – Satin stainless steel (ANSI 630, US32D)
- SPDT (Form C) switch – 5VA, Non-inductive
- Color coded 5 ft. lead wire harness with quick disconnect at switch unit for ease in installation

### Ordering Information

Model	Switch Actuation	Mounting	Switch Type SPDT (Form C)	Maximum Recommended Door Width When Used in an LSS/DPS Door Secure Indication Circuit with an RRBLS Lock
201030	Mechanical	Mortise	10 amps @ 250 VAC	48"
201090	Mechanical	Surface	10 amps @ 250 VAC	36"
201020	Magnetic	Mortise	0.5 amps @ 24 V maximum	Unlimited
201023	Magnetic	Mortise	5VA, Non-inductive	Unlimited

Note: Refer to the R.R. Brink "Hand of Locks Reference Guide" when ordering models 201030 or 201090.

Consult with our technical service personnel regarding custom applications such as retrofits to existing lock installations and special mounting situations.



**R.R. BRINK LOCKING SYSTEMS, INC.**

500 Earl Road • Shorewood, IL 60404  
Tel: 815-744-7000 • Fax: 815-744-7020  
www.rrbrink.com

# Function Guide for Motorized Locks

## Models 3520-300, 3520-600, 5020M and 7050M

### Available Lock Functions:

- 1 Maintained Switch Latch Holdback (MSLH) – Standard
- 2 Momentary Contact Latch Holdback – Mechanical (MCLH-M)
- 3 Momentary Contact Latch Holdback – Electrical (MCLH-E)
- 4 Maintained Switch Latch Holdback with Momentary Contact Latch Holdback – Electrical (MSLH/MCLH-E)

### Special Comments:

1. Control functions are depicted with maintained and/or momentary contact mechanical switches. Computer logic should match such operation.
2. With the 3020FSE, 5020S and 7050S solenoid actuated locks, the MSLH function is standard. The 2, 3, & 4 functions are optionally available.
3. With the 5520M and 5520S sliding door locks, the MCLH-E function is standard. The MSLH and MSLH/MCLH-E functions are available. The MCLH-M function is not available.
4. With functions 1, 3 & 4, manual key operation retracts the latch only. When the key is removed, the latch spring returns to the projected position. With function 2 key unlocking, the latch remains retracted mechanically (i.e. without power) until the door is opened.
5. A motor operated lock—with the MSLH function—is recommended over a solenoid actuated lock for applications requiring that a door be unlocked for a long time period (e.g. a cell door during daytime).



**R.R. BRINK LOCKING SYSTEMS, INC.**  
 500 Earl Road • Shorewood, IL 60404  
 Tel: 815-744-7000 • Fax: 815-744-7020  
 www.rrbrink.com

### 1 Maintained Switch Latch Holdback (specify MSLH)

With the maintained switch in “unlock”, the motor powers the latch to the retracted (unlocked) position. The latch remains retracted mechanically (i.e. without power), with the door open or closed, until the switch is returned to “lock.” The latch is then powered to the extended position and the door can be closed for relocking. (a.k.a. “half-cycle” function). This is the standard function for all RRBSL swinging door electric locks.

### 2 Momentary Contact Latch Holdback—Mechanical (specify MCLH-M)

Momentary power ( $\leq 1$  second) applied to the motor retracts the latch where it is held without power until the door is moved open far enough to release the auxiliary latch (a.k.a. deadlock trigger). At this time, the latch is extended mechanically and the door can be closed for relocking. (Note: With this function, upon electric unlocking the door must be physically moved ajar before the latch will project and allow for relocking. See MCLH-E function for remote relocking capability.)

### 3 Momentary Contact Latch Holdback—Electrical (specify MCLH-E)

Momentary power ( $\leq 1$  second) applied to the motor retracts the latch where it is held without power until the door is moved open far enough to release the auxiliary latch (a.k.a. deadlock trigger). At this time, the latch is extended electrically and the door can be closed for relocking. (Note: With this function upon electric unlocking, the latch can be projected to relock the door via a separate switch at the control panel without opening the door as required with the “MCLH-M” function.)

### 4 Maintained Switch Latch Holdback with Momentary Contact Latch Holdback—Electrical (specify MSLH/MCLH-E)

With a three – position switch, functions 1 and 3 can be combined into a single control station.

Two-position maintained contact switch **OR** Alternating action pushbutton switch

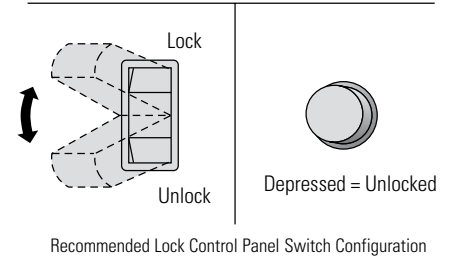

Momentary contact switch

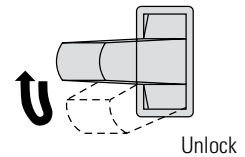

With momentary depression of switch, unit will unlock and automatically reset for slam-locking of door. Door must be opened for the lock to reset.

Recommended Lock Control Panel Switch Configuration

Momentary contact switch Relock switch

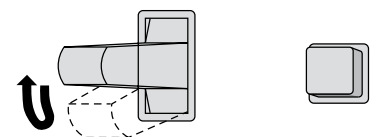

With momentary depression of switch, unit will unlock and automatically reset for slam-locking of door. Unit may be reset (relocked) without opening the door by depressing the relock switch.

Recommended Lock Control Panel Switch Configuration

Momentary contact switch Relock switch

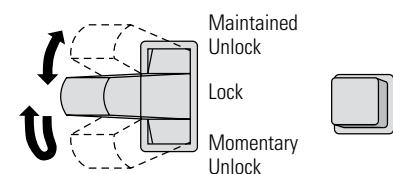

MSLH and MCLH-E switch configurations combined into a three-positioned maintained–maintained–momentary switch

Recommended Lock Control Panel Switch Configuration

# Head & Foot Bolt

## Heavy Duty Deadbolt Locks for Securing the Inactive Side of a Double Door Opening



**No. 70106HM  
Head and Foot Bolt**  
For use with hollow metal doors. Utilizes an RRBS No. 7080 lever tumbler deadbolt (3/4" bolt throw) with a 1" diameter stainless steel bolt extension.



**Head Bolt No. 70106HM/EL**  
Utilizes an RRBS No. 7080 lever tumbler deadbolt (3/4" bolt throw). Extended length 1" diameter stainless steel bolt and cover plate facilitates locking and unlocking of high, hollow metal doors (plate with paint primer).



**Head and Foot Bolt No. 70105HM**  
For mortise mounting in a hollow metal door. Key unlocking means inaccessible with active door closed and locked. A simple cam linkage throws the bolt 3/4" via a double tooth key. The 1" diameter bolt and cam is of stainless steel. The case is a painted steel weldment.

**Head and Foot Bolt No. 70105G**  
Identical to the 70105HM except furnished with side plates for use with grille or expanded metal doors.



**No. 70105FR**  
Floor bolt receptacle suitable for casting into concrete.



**No. 70105HBK/S**  
Head Bolt Keeper with Indication Switch



**No. 70105HBK**  
Head Bolt Keeper Plate  
3/16" x 1-3/4" x 5"



**R.R. BRINK LOCKING SYSTEMS, INC.**  
500 Earl Road • Shorewood, IL 60404  
Tel: 815-744-7000 • Fax: 815-744-7020  
www.rrbrink.com

### Application

The common use for head and foot bolts is to secure the inactive side of a double door opening. RRBS head and foot bolts feature the extra heavy duty construction appropriate for jail and prison security doors.

Two types of RRBS head and foot bolts are available – paracentric (70106HM) and double tooth key (70105HM/G) operated. The former offers the added convenience and security of keying to a lever tumbler combination as compared to a plain tool. The latter prevents

unlocking of the inactive door of a pair when the active side is closed and locked.

# Hinge Series

## Heavy-Gauge, Detention Grade Hinges

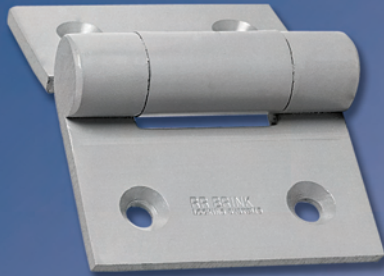

#3 Access Panel Hinge

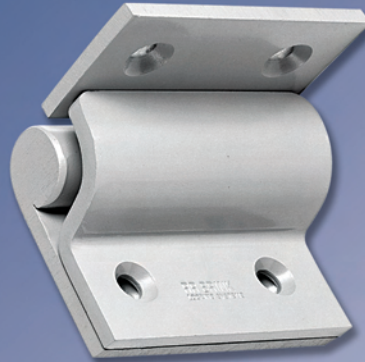

#3FP Food Pass Hinge



#4-1/2 Institutional Full Mortise Template Hinge



#5 Heavy Duty Prison Hinge  
(Available with mounting holes)

### #3 Access Panel Hinge

Application and Features

- Use with electrical and mechanical system access panels or other small doors.
- Fabricated from cold rolled steel.
- Pin welded in-place.
- Security fasteners included.
- Finish – primed for paint.

### #3FP Food Pass Hinge

Application and Features

- Use with cell door food pass shutters. Stop added to the #3 hinge limits shutter opening rotation to 90° to form a shelf.
- Features same as #3 hinge.

### #41/2 Institutional Full Mortise Template Hinge

Application and Features

- Use with conventional sized security hollow metal doors.
- Cast stainless steel leaves and welded in-place stainless steel pin construction.
- Hospital tips and integral anti-shear studs.
- Anti-friction bearings.
- Conforms to ANSI A156.7 template dimensions.
- Meets ASTM F1758 Grade 1 requirements.
- Finish – US32D (BHMA 630) satin stainless steel or USP - primed for paint.
- Security fasteners standard.
- Through-wire, electric power transfer model available 5 wire 18 awg

### #5 Heavy Duty Prison Hinge

Application and Features

- Use with prison type grille and plate doors – surface mount.
- Barrel and leaves fabricated from cold rolled steel – welded assembly.
- Steel pin welded in-place.
- Anti-friction bearings.
- Standard finish USP – primed for paint.
- Security fasteners standard.
- Leaves available with screw holes or without to allow welding to door.



**R.R. BRINK LOCKING SYSTEMS, INC.**  
500 Earl Road • Shorewood, IL 60404  
Tel: 815-744-7000 • Fax: 815-744-7020  
www.rrbrink.com

# Hinge Series

Heavy Gauge, Detention Grade Hinges

**#3 Access Panel Hinge**

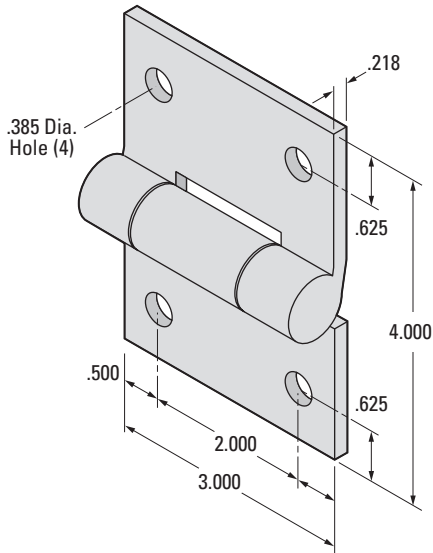

**#3FP Food Pass Hinge**

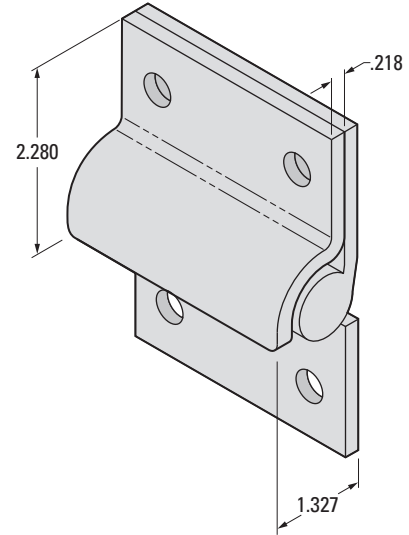

**#4 1/2 Institutional Full Mortise Template Hinge**

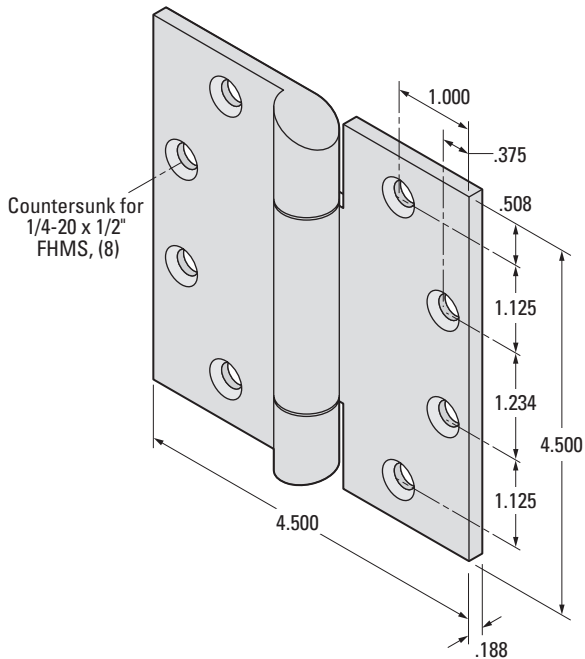

**#5 Heavy Duty Prison Hinge**

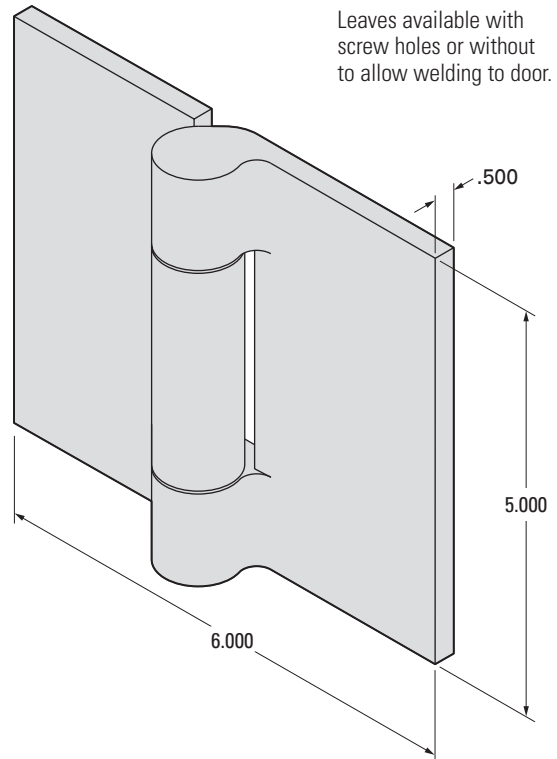

**R.R. BRINK LOCKING SYSTEMS, INC.**

500 Earl Road • Shorewood, IL 60404  
Tel: 815-744-7000 • Fax: 815-744-7020  
www.rrbrink.com



# Test Boxes

## Testing and Troubleshooting

For All R.R. Brink Electrical Locks & Sliding Devices



### B00043-A

#### Application and Features

- For testing all **120v** motor & solenoid locks:
  - 5020M
  - 5020S
  - 7050M
  - 7050S
- Includes Adapter for:
  - 7050M/7050S
- Tests All Functions:
  - MSLH
  - MCLH-M
  - MCLH-E
- Shipped with instructions and troubleshooting guide.

### B00068-A

#### Application and Features

- For testing all **24v** motor & solenoid locks with **Fail Secure**:
  - 3520-300
  - 3520-600
  - 5020M
  - 7050M
  - 3020 FSE
  - 1050FSE
  - 2020FSE
- Tests All Functions:
  - MSLH
  - MCLH-M
  - MCLH-E
- Shipped with instructions and troubleshooting guide.

### B00069-A

#### Application and Features

- For testing all **24v** solenoid locks with **Fail Safe**:
  - 3020FS
  - 2020FS
  - 1050FS
- Tests All Functions:
  - MSLH
  - MCLH-E
- Shipped with instructions and troubleshooting guide.

### B00080-000

#### Application and Features

- For testing **sliding cell** and corridor devices:
  - 57700
  - 57300
- Includes Adapters for:
  - 57300



**R.R. BRINK LOCKING SYSTEMS, INC.**  
500 Earl Road • Shorewood, IL 60404  
Tel: 815-744-7000 • Fax: 815-744-7020  
www.rrbrink.com

# Key Cylinders

## High Security Cylinders



R.R. Brink Lever-Tumbler

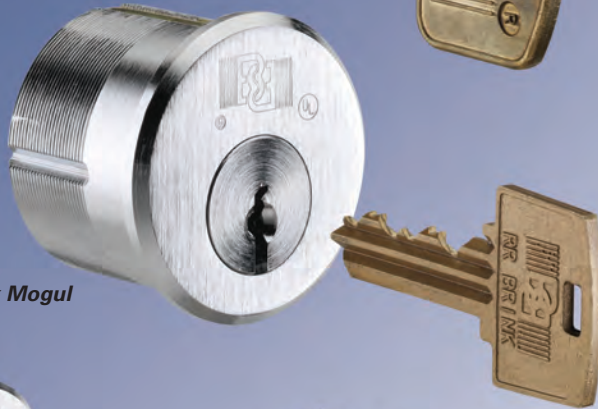

R.R. Brink Mogul



ASSA®



MEDECO®

All keys shown must be ordered separately

internal parts (i.e. pins, springs, balls, and cylinder plug) as well as the external cylinder body or housing. (The diameter of the "Mogul" is 2" and the standard cylinder is 1-5/32".) Compared to a standard mortise cylinder, the "Mogul" parts offer proportionately larger wear surfaces and a longer life cycle. Also, the larger cross sectional area of the "Mogul" keyway facilitates the removal of debris commonly inserted by inmates to impede key operation. Second, the dimensions of the "Mogul" key are roughly twice that of a standard mortise cylinder key. This key size reduces the chance of breakage under forced turning (e.g. against a bind) and affords increased torque to ease the unlocking of heavy prison lock mechanisms. Also, the "Mogul" key size lends itself to easy insertion into the cylinder keyway.

For detention facility applications when it is desired to master key both commercial and detention grade locks on one system, we recommend specification of a "high security" brand of mortise cylinder which affords pick resistance and key blank control. RRBS is an authorized OEM dealer for both ASSA® and MEDECO® high security cylinders. Unless otherwise specified, we provide either the standard mortise ASSA® or MEDECO® brand with our factory key cylinder (FKC) option\*. When our locks are equipped with ASSA® or MEDECO® cylinders, we can provide direct factory to user service for replacement cylinders and keys. We stock their cylinder parts and certain proprietary key blanks so that we are able, on short notice, to pin new cylinders and cut keys.

*\*The ASSA® and MEDECO® companies market a "Mogul" version of their standard size high security mortise cylinders. Whereas these products have the same 2" diameter body as the RRBS "Mogul" cylinder, that is where the similarity ends. All internal parts as well as the key furnished with their "Mogul" versions are identical to their standard product. Thus, the distinctive feature of the RRBS "Mogul" cylinder (i.e. all internal parts and key being larger in proportion to its 2" diameter body) cannot be ascribed to these variations of a standard product.*

*Our motive in making this distinction is not to discourage the use of high security key cylinders with detention grade locks. The purpose is to point out to specifiers and end users that, with our locks, the ASSA® or MEDECO® "Mogul" cylinder offers no functional advantage over their standard size product. Therefore, we recommend use of their standard size product with the attendant cost saving.*







**R.R. BRINK LOCKING SYSTEMS, INC.**  
500 Earl Road • Shorewood, IL 60404  
Tel: 815-744-7000 • Fax: 815-744-7020  
www.rrbrink.com

### Application

With the exception of the 7000 Series lever tumbler models, all R.R. Brink Locking Systems' locks must be fitted with a mortise, pin tumbler key cylinder for manual unlocking. Our locks can be ordered to accept either a standard builder's hardware mortise cylinder or the prison "Mogul" type, as shown above.

In correctional facilities, the RRBS "Mogul" is often the cylinder of choice for detention grade locks only. This product differs from the standard mortise cylinder\* (a.k.a. builder's hardware cylinder) in two significant aspects. First, all components of the RRBS "Mogul" cylinder are approximately twice the size of the conventional mortise type. This size difference includes the

# Key Cylinder Comparison

	MEDECO® Mortise Pin-Tumbler Key Cylinder*	ASSA® Mortise Pin-Tumbler Key Cylinder*	R.R. Brink Mogul Pin-Tumbler Key Cylinder*	R.R. Brink Lever-Tumbler Key Cylinder**
				
<b>Compatible with R.R. Brink lock models</b>	1040, 1050, 1060, 1070, 2020, 2050 3020, 3520-300, 3520-600 5020S, 5020M, 5020EUKL, 5520, 8030, 8050, 8055 9010, 9017		1020, 1030, 1040, 1050, 1060, 1070, 3020 3620-300, 3620-600 5020S, 5020M 5020EUKL, 5520 7010M, 7017M 8050, 8055, 9025	7010, 7017, 7030 7030D, 7050S, 7050M, 7060, 7060K 7070, 7080
<b>Cylinder housing thread</b>	1.156" x 32	1.156" x 32	2.000" x 27	N/A
<b>Cam type</b>	Yale	Yale	RRBLS	N/A
<b>Standard finishes</b>	Satin Chromium on Brass, ANSI 626, US26D Satin Brass, ANSI 606, US4			Available in silicon bronze finish only
<b>U.L. 437 (Key Locks) listing</b>	Yes	Yes	Yes	No
<b>Master and grand master keying available</b>	Yes	Yes	Yes	No
<b>Affords most key combinations</b>	X	X		
<b>Affords most hand torque</b>			X	X

**Notes:**

\* When specifying an RRBLS supplied key cylinder, specify FKC-MEDECO, FKC-ASSA, or Mogul and all necessary keying information after the lock model number. With lever-tumbler locksets, there is no need to specify the key cylinder, since it is included.

\*\* R.R. Brink includes as standard its lever-tumbler key cylinder with lock models 7010, 7017, 7030, 7030D, 7050S, 7050M, 7060, 7060K, 7070, and 7080. These lock models must be operated by this type of key cylinder.



**R.R. BRINK LOCKING SYSTEMS, INC.**

500 Earl Road • Shorewood, IL 60404  
Tel: 815-744-7000 • Fax: 815-744-7020  
www.rrbrink.com

# Key Switches



201095

201065

201070

201110

## 201095 – Narrow Mortise Cylinder Key Switch

This narrow profile key switch is designed to mortise mount in the 2" trim surface of a standard hollow metal door frame.

- Units can be ordered with one or two momentary (MO) or maintained (MA) action SPDT switches or a combination for actuation by clockwise and/or counter-clockwise key rotation to suit the application. Specify No. 201095 – 1MO or 2MO, or No. 201095 – 1MA or 2MA, or No.201095 – 1MO & 1MA, respectively.
- Electrical rating: 250VAC, 5A resistive; 30VDC, 3A inductive & 5A resistive.
- Accepts any manufacturers standard 1-1/8" long mortise cylinder with a "Yale" shape cam.
- When ordered, can be supplied with quick-disconnect wire leads (i.e. not standard).
- Optionally available with two LEDs (typically green and red).
- Standard faceplate finish – satin stainless steel (ANSI 630 , US32D).

## 201110 – Standard Mortise Cylinder Key Switch

This key switch is designed to mount in a 2" x 4" electrical outlet box - 2" minimum depth (e.g. Raco handy box No. 674, shown, or equal). Features are identical to Model No. 201095.

## 201065 – Paracentric Key Switch

This key switch is ordinarily used in jails and prisons to complement an RRBLS lever tumbler keying system.

- Normally fitted with two momentary (snap) action SPDT switches (Form C) for actuation by clockwise and/or counterclockwise key rotation. Electrical rating: 125/250VAC, 15A resistive.

Standard models available in one (No. 201065-1) or two side (No. 201065-2) keying.

- Furnished with quick-disconnect wire leads.
- Electroplated steel parts.

## 201070 – Mogul Cylinder Key Switch

This key switch employs an institutional style Mogul cylinder.

- Standard model accepts RRBLS Mogul cylinder (2.000" x 27 thread x 1-3/4" long x Yale type cam). The 201070 can be adapted for use with other manufacturers' Mogul cylinders by special order.
- Normally fitted with two momentary action SPDT switches (Form C) for actuation by clockwise and/or counterclockwise key rotation. Electrical rating: 125/250VAC, 15A resistive.
- Optionally available with one or two shatter resistant LED's in green and red as specified.
- Furnished with quick-disconnect wire leads.
- Standard faceplate – electroplated steel.

## Application

A typical application for a key switch in a correctional facility is for proximity key control of an RRBLS electromechanical sliding or swinging door lock. A key switch can provide an additional security measure where key unlocking of electric locks is routine. A key combination different from the lock's manual key, which can be safe-guarded for use during power interruptions only, operates the key switch. Also, the wiring of the key switch is configured to allow on and off power switching from a central control station. Thus, if the key to the switch cylinder is lost or seized, the key switch can be disabled to prevent unauthorized unlocking of the door.



**R.R. BRINK LOCKING SYSTEMS, INC.**  
500 Earl Road • Shorewood, IL 60431  
Tel: 815-744-7000 • Fax: 815-744-7020  
www.rrink.com

# Key Switch Schematics (Not For Construction)

## 201070 – Mogul Key Switch

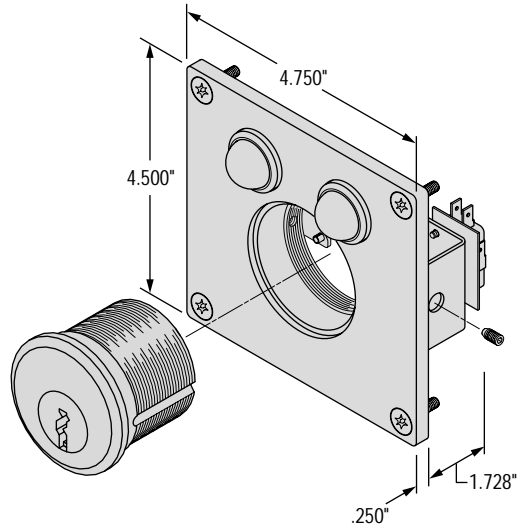

Note: Keys for Mogul cylinder must be ordered separately.

## 201095 – Key Switch

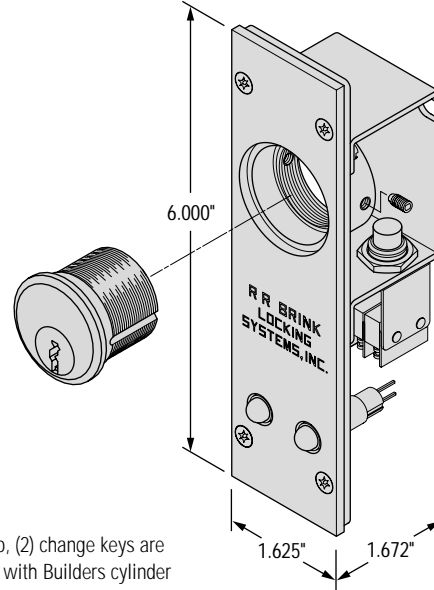

Note: Two, (2) change keys are furnished with Builders cylinder

## 201110 – Key Switch

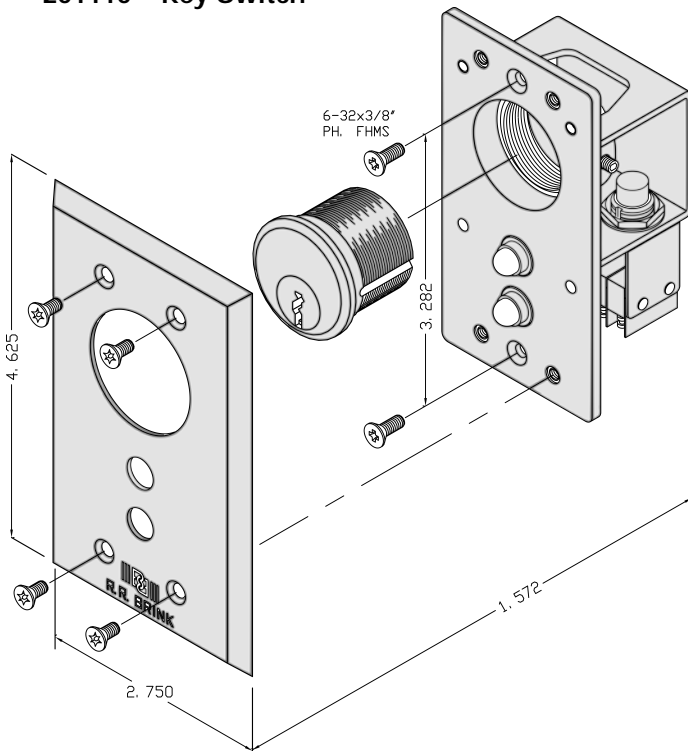

Note: Two, (2) change keys are furnished with Builders cylinder

## 201065 – Paracentric Key Switch

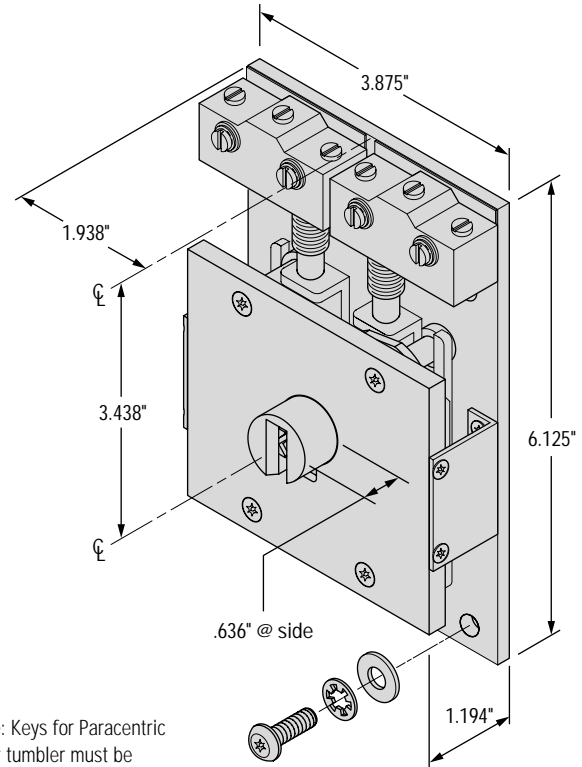

Note: Keys for Paracentric lever tumbler must be ordered separately.

### Options applicable to RRBSL key switches with a pin tumbler cylinder (Models 201070, 201095, and 201110):

1. The cylinder can be factory modified to limit the rotation of one key (i.e. change level) to the clockwise direction only. A second key (i.e. master level) rotates in both directions. Thus, by a connection to a control panel override switch, the change key operation can be disabled while the master key can be operative at other or all times. This allows restrictions on door unlocking and other key switch operations by key holders (e.g. correctional officers) during certain periods. Specify "controlled key switch" (CKS).
2. The optional LEDs are often wired to lock and door status switches (LSS & DPS) to indicate deadlocked and/or unlocked door conditions (see the LSS standard feature of RRBSL electromechanical locks). Also, the LEDs can be wired to illuminate when the key is turned in the clockwise (CW) or counterclockwise (CCW) directions only or one LED can illuminate upon CW and the second upon CCW rotation.



**R. R. BRINK LOCKING SYSTEMS, INC.**  
 500 Earl Road • Shorewood, IL 60431  
 Tel: 815-744-7000 • Fax: 815-744-7020  
 www.rrbrink.com

# R.R. Brink Locking Systems, Inc.

## Hand of Locks Reference Guide

When ordering RRBSL locks, please refer to this Reference Guide for proper designation of lock handing.

### Jamb Mortise Mounted Electromechanical Locks (K1S or K2S)

RRBSL Lock Models 2020, 2050, 3020, 3520-300, 3520-600 Note: header mounted locks require opposite hand lock.

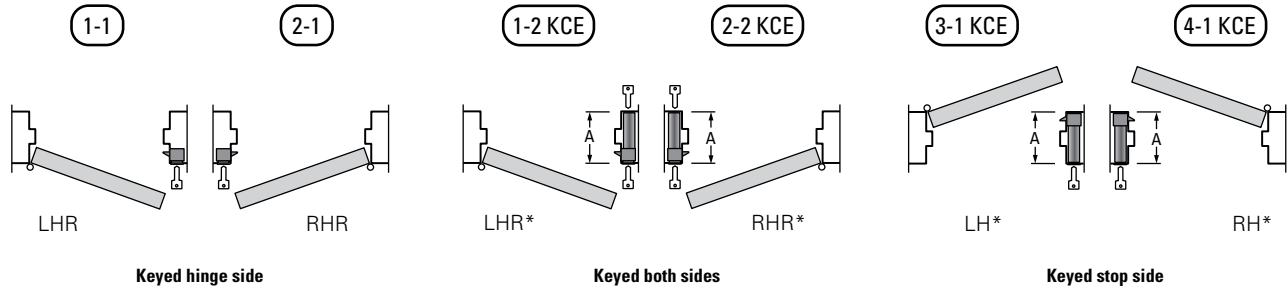

### Jamb Mounted to Frame Plate Electromechanical Locks (K1S)

RRBSL Lock Models 5022, 7052

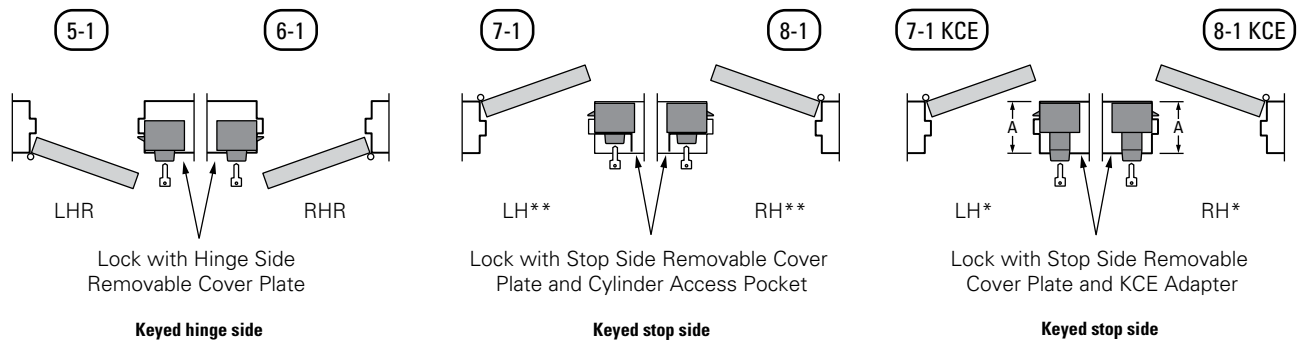

### Jamb Mounted to Frame Plate Electromechanical Locks (K2S)

RRBSL Lock Models 5026, 7056

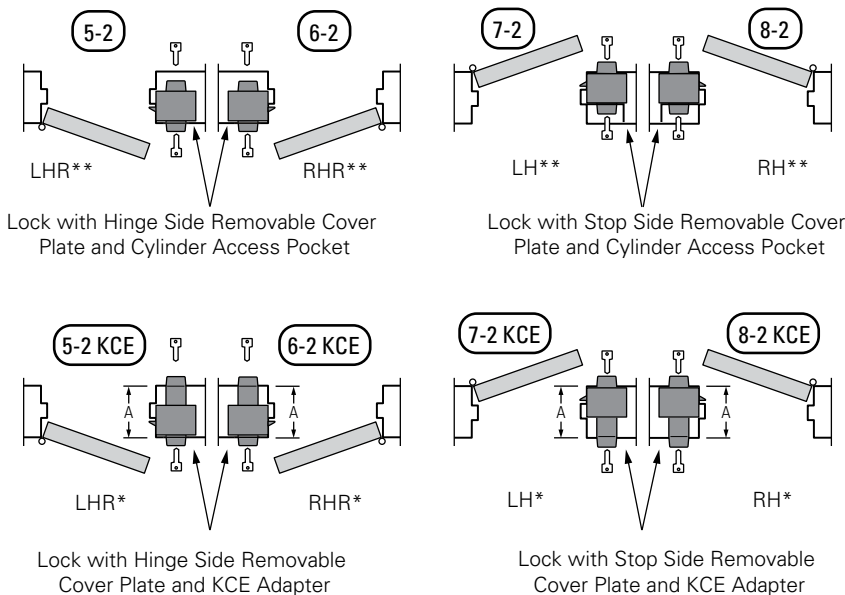

Notes:

\* Requires key cylinder extension (KCE) adapter. When ordering, provide outside frame depth (dimension "A"). For explanation of KCE adapter, see specific product catalog page.

\*\* The diagram depicts a stop side key cylinder access pocket that is custom fabricated in the door frame.

# R.R. Brink Locking Systems, Inc.

## Hand of Locks Reference Guide

When ordering RRBSL locks, please refer to this Reference Guide for proper designation of lock handing.

### Door Mounted Mortise Locks (K1S or K2S)

RRBLS Lock Models 1020, 1030, 1040, 1050, 1060, 1070

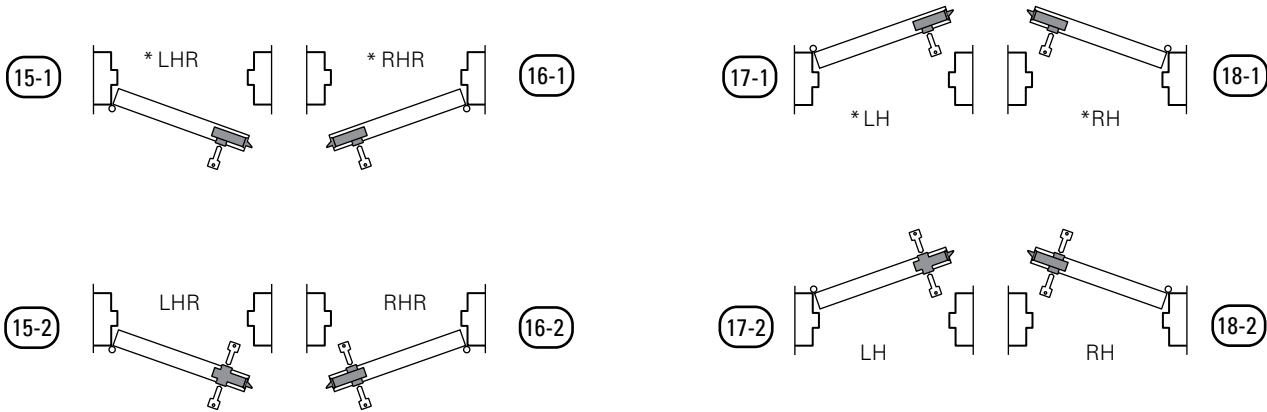

\*Note: Shown keyed on the outside. Key side depends on lock function.

### Lever Tumbler Locks with Mounting Plate Surface Attached to Hollow Metal Door (K1S or K2S)

RRBLS Lock Models 7010, 7060, 7060K, 7070, 7080

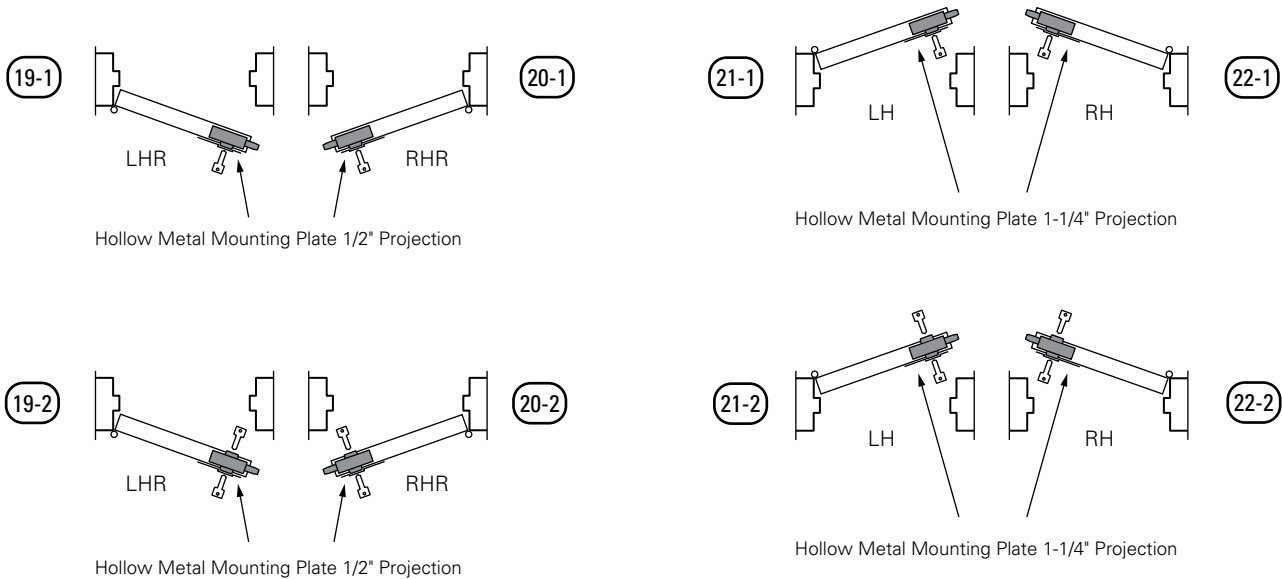

### Sliding Door Locks

RRBLS Lock Models

5520  
8055  
7030  
7030D  
57000

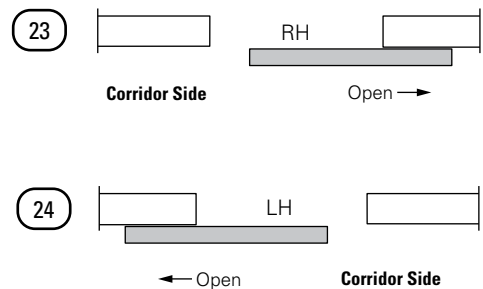

**R.R. BRINK LOCKING SYSTEMS, INC.**

500 Earl Road • Shorewood, IL 60404  
Tel: 815-744-7000 • Fax: 815-744-7020  
www.rrbrink.com

# Locking Accessories

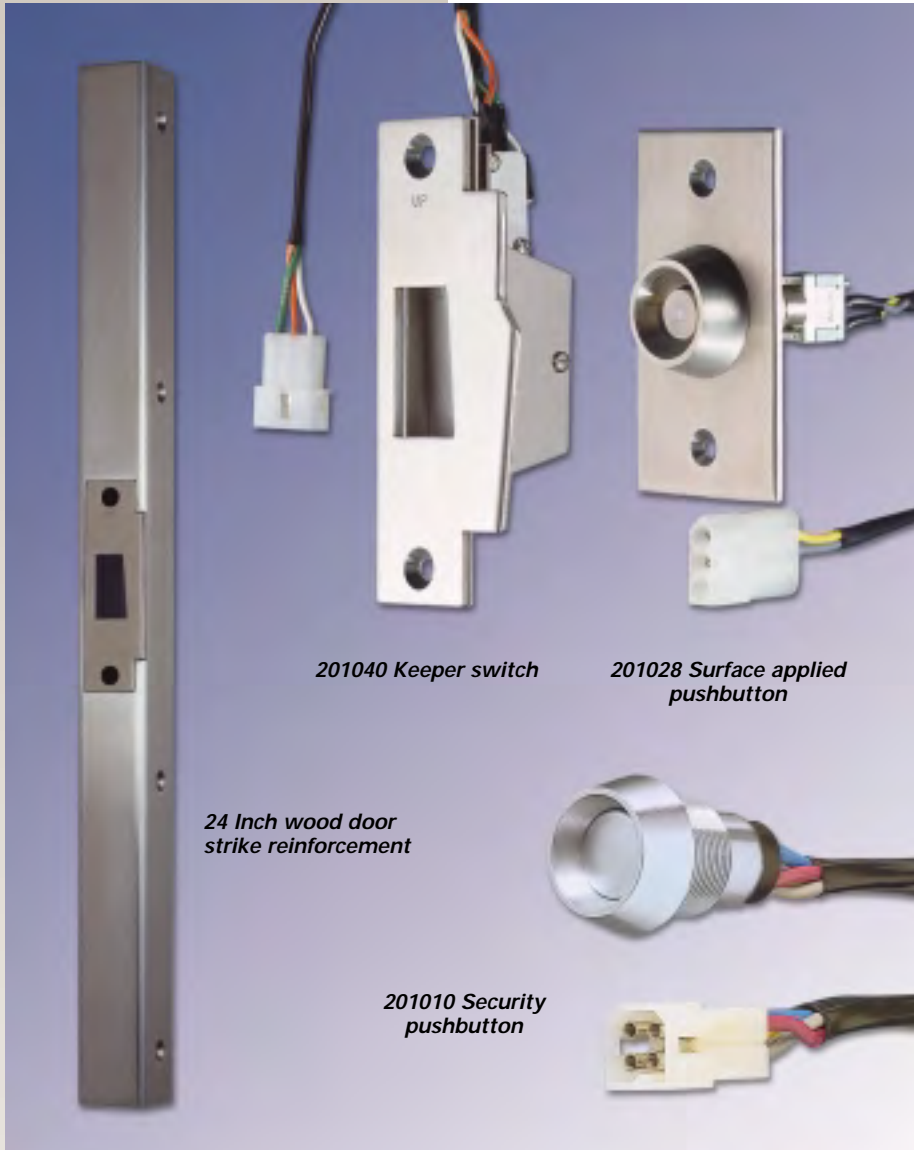

24 Inch wood door  
strike reinforcement

201040 Keeper switch

201028 Surface applied  
pushbutton

201010 Security  
pushbutton

## 201040 Latch Keeper Switch

For use with RRBLS door mounted, key operated mortise lock models 1040, 1060 and 1070 to indicate engagement of the latch in the keeper. It is recommended that the 201040 be interconnected with an RRBLS door position switch to reduce the possibility of a false reading of latch engagement with a door ajar. (Note: Open door hand manipulation of the 201040 actuator paddle is an unavoidable possibility.) All parts of the 201040 are of stainless steel stampings. The switch (form C) rating is 10 amps @ 250VAC. When ordering, advise mating lock model (i.e. 1040/1060 or 1070).

## 201010 Tapered Housing Pushbutton Switch

The 201010 pushbutton assembly mounts in the doorframe lock pocket opposite the key cylinder. Since there are no exposed fasteners, it is irremovable from the exterior. The 201010 was designed originally for use in a correctional facility as an inmate cell door unlock/guard call switch, in conjunction with an RRBLS electromechanical lock. However, it is applicable wherever its unique mounting can be utilized to provide tamper resistance. The switch has an encapsulated DPDT configuration with a rating of 6 amps @ 120VAC and 4 amps @ 24VDC. The wire leads are furnished with quick disconnect plugs. Standard switch holder finishes are ANSI 606 (US4) and ANSI 626 (US26D).

## 201044 Recessed Pushbutton Switch

The 201044 pushbutton assembly is identical to the No. 201010 except that it recess mounts into the frame. Note: The frame supplier must provide an internal welded-in-place mounting plate (see schematic illustration over).

## 201028 Surface Mounted Pushbutton Switch

The 201028 pushbutton assembly is identical to the No. 201010 except that it surface mounts with exposed fasteners, ordinarily on the exterior trim of a door frame. When ordering, specify Phillips or pinned Torx head mounting plate screws.

## Wood Door Strike Reinforcement

A strike reinforcement is recommended when an RRBLS jamb mounted electro-mechanical lock is used with a solid core wood door. This door edge mortise, wrap-around design provides a rigid metal mounting for the lock strike plate. It enhances the strength of the wood door locking assembly as compared to direct screw attachment of the strike. The standard unit is 24" long and fabricated from stainless steel for either a 1-3/4" or 2" thick door (specify). Custom made lengths are available as specified.



**R.R. BRINK LOCKING SYSTEMS, INC.**  
500 Earl Road • Shorewood, IL 60431  
Tel: 815-744-7000 • Fax: 815-744-7020  
www.rrbrink.com



# Locking Accessories

## 201028 – Surface Applied Pushbutton

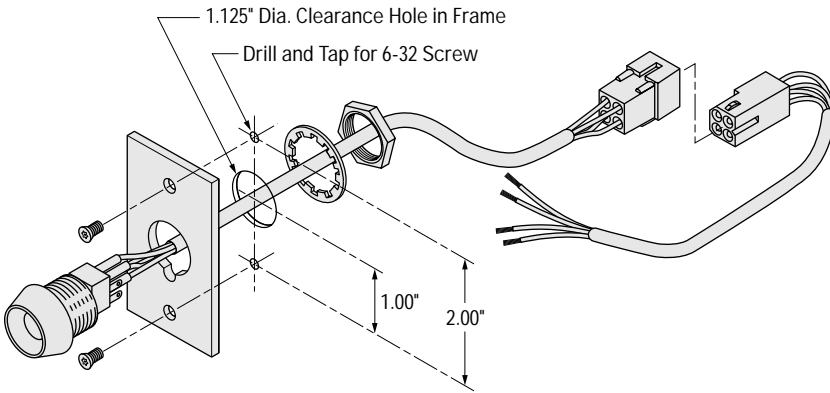

## 201010 – Security Pushbutton

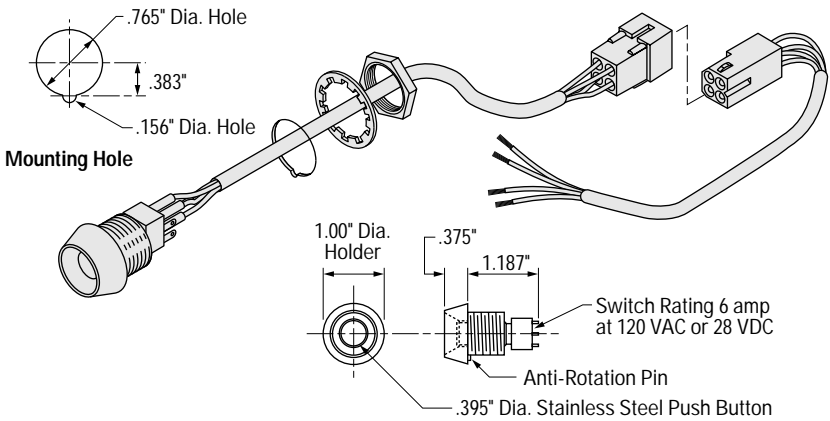

## 201044 – Security Pushbutton

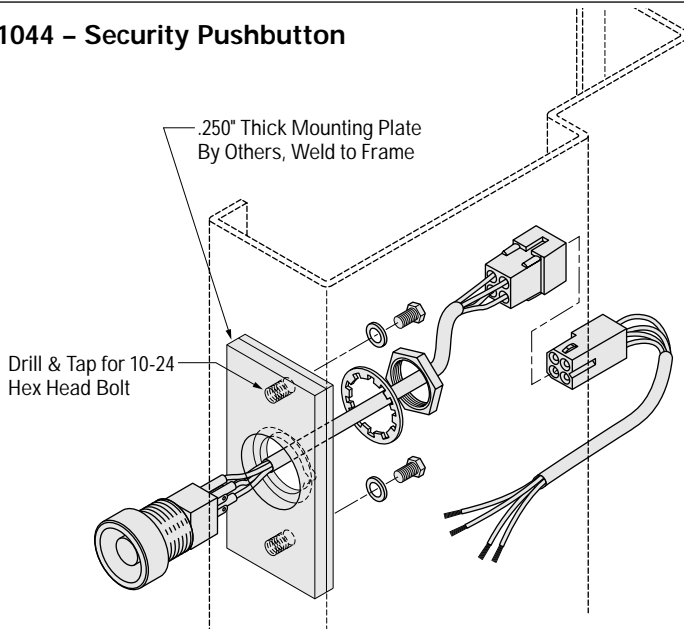

## Wood Door Strike Reinforcement 24" Length

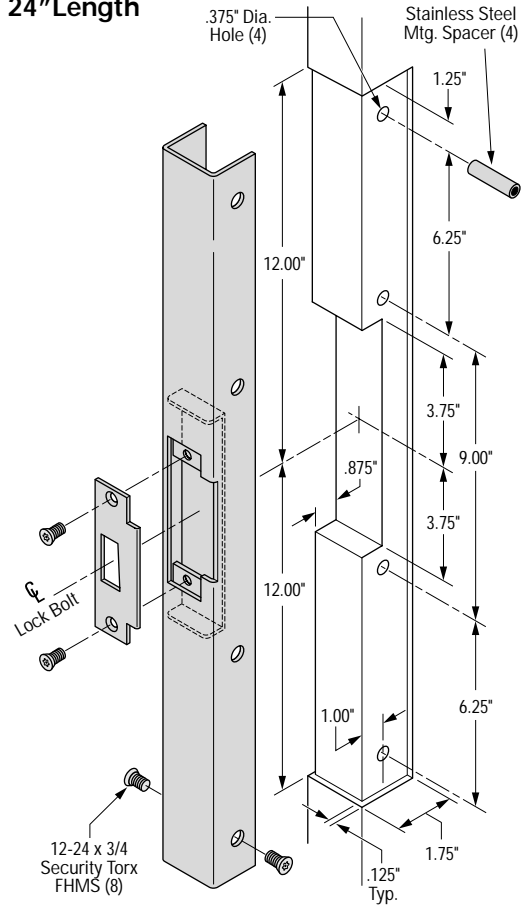

## 201040 – Keeper Switch

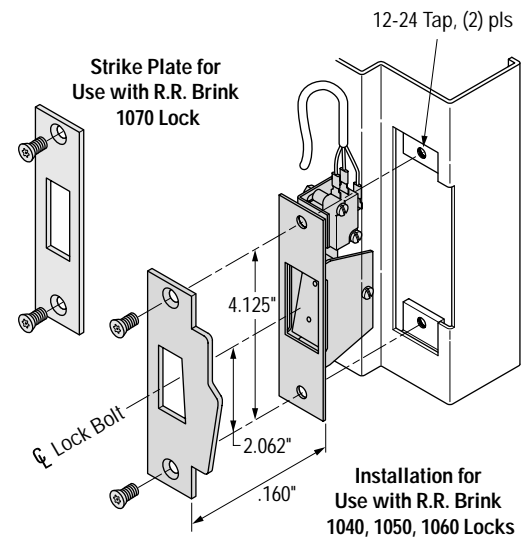

**R.R. BRINK LOCKING SYSTEMS, INC.**  
 500 Earl Road • Shorewood, IL 60431  
 Tel: 815-744-7000 • Fax: 815-744-7020  
 www.rrbrink.com

Note:  
 1. Consult factory for complete frame preparation on all locking accessories. Do not use the above drawings for construction.

# Product Warranty Policy

R.R. Brink Locking Systems, Inc. (RRBLS) warrants that products of its manufacture only shall be without material and workmanship defects of factory origin. The effective period of this warranty shall be the first date of either eighteen (18) months from the date of product shipment or twelve (12) months from project turnover. RRBLS, at its option, reserves the right to repair, replace or return an allegedly defective part or product provided the customer or user complies with the following:

1. Returned product(s) have been stored, installed, maintained and operated in accordance with RRBLS recommendations. Their installation has been in accordance with good construction industry practices and standards. (RRBLS does not warrant against abusive use, willful damage, or "Acts of God")
2. Returned product(s) have not been adjusted, altered, modified or repaired without the consent of RRBLS.

3. Electrical components have been operated only with the proper polarity and rated voltage.
4. Obtain from an RRBLS in-house customer service representative a "return goods authorization number" and ship the product(s) prepaid to the address thereon.

Product(s) supplied by, but not manufactured by, RRBLS carry only the warranty expressed by the manufacturer.

For out-of-warranty factory product repair or part replacement, a "repair order number" must be obtained from an RRBLS in-house customer service representative. Thereupon, ship the item(s) prepaid along with a purchase order authorizing the necessary work. The attendant charge will be based on expended labor and material. If requested, a quotation will be issued based on our assessment of the product(s) condition.

# Warranty Period Field Repair Policy

A purchaser or user of an in-warranty product manufactured by RRBLS claiming a site repairable defect must receive technical input and written authorization from RRBLS before proceeding with reimbursable work. Without such authorization, RRBLS shall not accept related backcharges and shall void outstanding warranties on the subject product.

This policy protects RRBLS against inappropriate and unjustifiable backcharges and disputes. It assures the product user that remedial work performed by others in the field will not jeopardize the RRBLS written warranty.

# Door/Frame Preparation Drawing and Wiring Diagram Policy

Door/frame drawings and wiring diagrams must be issued by an RRBLS in-house customer service representative on a per order basis only. Such drawings and diagrams shall be referenced to the assigned RRBLS work order number. RRBLS assumes no responsibility for door/frame preparation or wiring inconsistencies due to the use of drawings or diagrams not referenced to an order. RRBLS assumes responsibility for shipping

material according to drawings issued for a specific work order.

RRBLS reserves the right to change or modify cataloged product descriptive information, door/frame preparation drawings and wiring diagrams without notice.

**WARNING: DO NOT USE CATALOG INFORMATION FOR CONSTRUCTION PURPOSES.**



**R.R. BRINK LOCKING SYSTEMS, INC.**  
500 Earl Road • Shorewood, IL 60404  
Tel: 815-744-7000 • Fax: 815-744-7020  
www.rrbrink.com