

3620-300

Motorized Deadlocking Latch with Mogul Key Cylinder

Narrow profile, designed for metal frame mounting in a 3" trim jamb/header. The 24VDC motor drive retracts latch against side loads of 300 pounds.



Application

- The 3620-300 is ideal for access control in secure areas of commercial, institutional, governmental, and industrial buildings.
- The 24VDC gearmotor achieves remote unlocking even when an abnormally high 300 pound side force is applied against the latch.
- Available functions allow for electrical latch retraction and extension from a remote control point as well as manual key unlocking at the door.
- Standard with RRBSL 2" diameter detention grade Mogul cylinder. Workable with 2" diameter builders' hardware brands. See "Key Cylinders" catalog page for elaboration.
- This lock is commonly used in medium security correctional facilities to provide remotely controlled electric unlocking of detention area sleeping room and exit doors.

(Note: Not recommended for maximum security detention applications.)

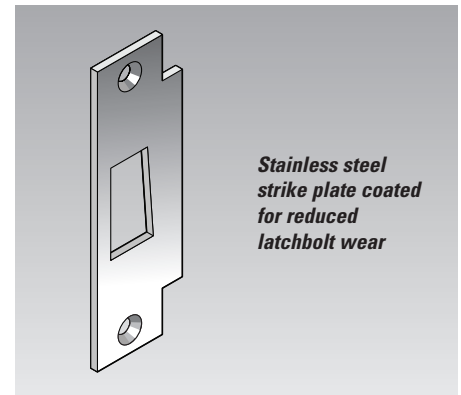

R.R. BRINK LOCKING SYSTEMS, INC.

500 Earl Road • Shorewood, IL 60404
Tel: 815-744-7000 • Fax: 815-744-7020
www.rrbrink.com

3620-300

Motorized Automatic Deadlocking Latch with Mogul Key Cylinder

Narrow profile, designed for metal frame mounting in a 3" trim jamb/header. The 24VDC gearmotor drive retracts the latch against side loads of 300 pounds.

Standard Features

- Structural and locking parts are stainless steel
- All other parts and fasteners of copper alloy or stainless steel
- A full 3/4" throw cast stainless steel latch with two (2) saw resistant inserts.
- Standard with RRBL5 2" diameter detention grade Mogul cylinder. Workable with 2" diameter builders' hardware brands. See "Key Cylinders" catalog page for elaboration.
- Maintained Switch Latch Holdback (**MSLH**) function (see "Motor Lock Function Reference Guide" for other functions).
- Lock status switch (**LSS**) trips when latch is in deadlocked condition. Used in a signal circuit to indicate lock status – unlocked or deadlocked – via control panel lights and/or alarm devices. The LSS is also used to control an electrical interlock, which permits only one of a group of doors to be unlocked at any time. *Note: For positive, tamper resistant signaling of a closed and deadlocked door, a sensitive door position (DPS) switch must be wired in combination with the LSS. Our DPS Models 201030 or 201090 are recommended.*

- For stop (push) side frame keying see optional "key cylinder extension" (**KCE**).
- Plug connectors are provided for ease in wiring and removal.
- Exposed fasteners – pinned "Torx" head
- Exposed Faceplate
Satin Stainless Steel – (ANSI 630, US32D)

Electrical Data

- Gearmotor – Permanent magnet type – 1.0 ampere current limited at full load. Voltage must be 24VDC, +5% -10%. A regulated power supply is recommended for optimum performance.
- Lock Status Switch – 120/250VAC, 5 amp, SPDT (Form C)

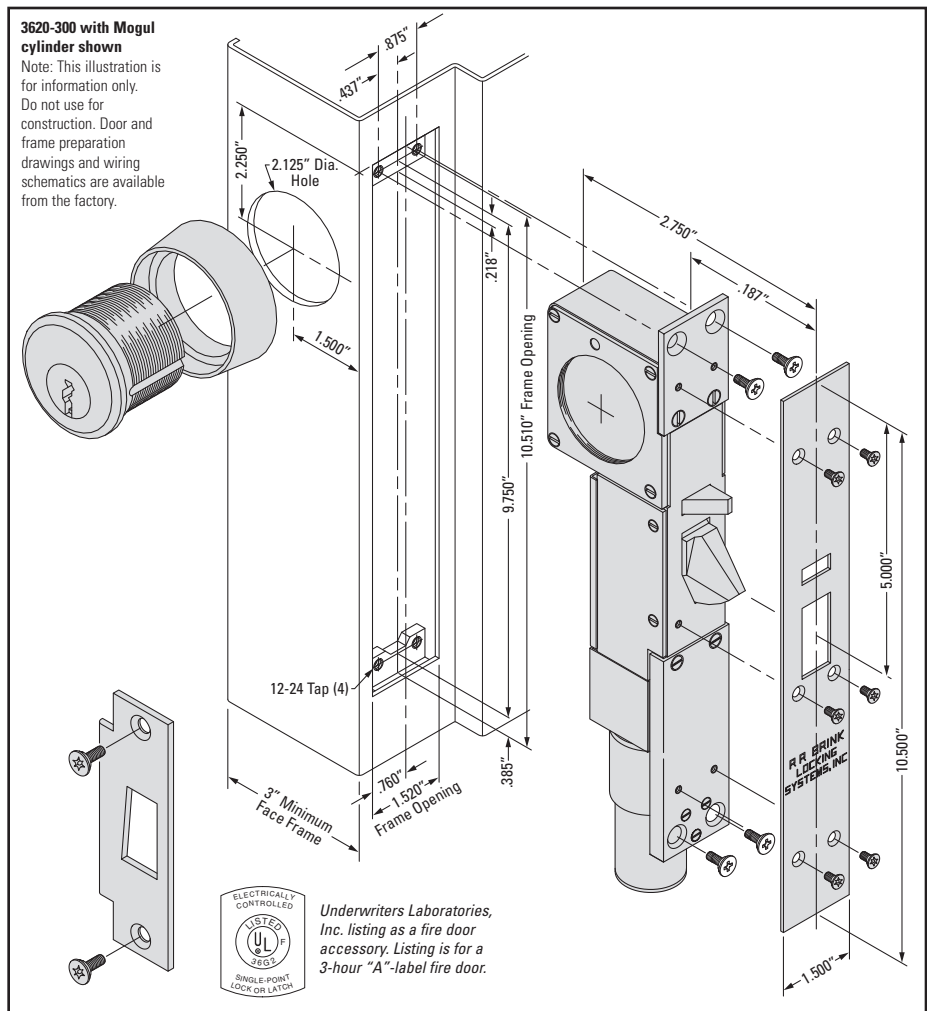

Optional Features

- **KCE** – Stop (push) side key cylinder extension extends working length of a standard or mogul mortise key cylinder to adapt to jamb depths within a range of 4" to 9" (advise jamb depth dimension). Customer supplied cylinders must be factory fitted to each KCE.
- **CKS** – Factory key cylinder modification and an internal limit switch produce a key switch feature which electrically actuates the lock by one way only rotation of the change level key. This feature can be rendered inoperative by switch from a remote control panel. Mechanical

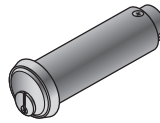

unlocking is by a master level key. This feature is indicated when it is desirable to restrict periods when key unlocking is possible, e.g. building access or prison inmates who carry a key to their cell.

- **RC** – Rectifier with plug-in adapter permits 24VAC input

Consult with our technical service personnel regarding custom applications such as retrofits to existing lock installations and special mounting situations.

Ordering Information – 3620-300 Electromechanical Series

Model	Description	Key Cylinder Extension (KCE)
3622-300	3620-300 keyed one side	Required if key cylinder is mounted on stop (push) side of frame
3626-300	3620-300 keyed two sides	Required on stop (push) side of frame



R.R. BRINK LOCKING SYSTEMS, INC.
 500 Earl Road • Shorewood, IL 60404
 Tel: 815-744-7000 • Fax: 815-744-7020
 www.rrbrink.com

Model & Key Code(s)	Function	Optional Features	Hand of Lock	Faceplate Finish	Door Thickness
Example: 3622-300	MSLH	KCE	LHR	US32D	Door Thickness
3622-300 Keyed 1 side	See our "Motor Lock Function Reference Guide" for a full description of available lock functions.	See the "Optional Features" section above for description and symbol.	See our "Hand of Locks Reference Guide" for description and symbol.	US32D Satin Stainless Steel (ANSI 630)	1-3/4" or 2"
3626-300 Keyed 2 sides					